



## SUBSEA LINEAR ACTUATOR

QUIET, RELIABLE, AND EFFICIENT



Moog's Naval Systems Business Unit is the premier supplier of custom designed, high performance motion control solutions for mission critical undersea applications. Moog actuation systems provide industry leading reliability and efficiency and are closely tailored to the needs of each customer. This data sheet describes an existing linear actuation product. Moog will customize this or other designs to suit your application.

### KEY FEATURES

- Customizable to meet your specific needs
- High reliability
- High efficiency
- Low noise



# SUBSEA LINEAR ACTUATOR

## PERFORMANCE

Features	Specifications
Stroke	4"
Force	250 lbs
Speed	2"/s
Input power	1.5 A at 110VDC
Weight	<1.4 kg; <3.09 lbs
Pressure compensated for external environment up to 9000 PSI	



## DESIGN FEATURES

- Wet ball screw design
- No leak prone dynamic linear seals
- Low compensator volume required
- PBOF motor cavity
- Moog BLDC motor
- Resolver based position indication
- Several controller options available

## ARCHITECTURAL AND DIMENSIONAL DRAWING

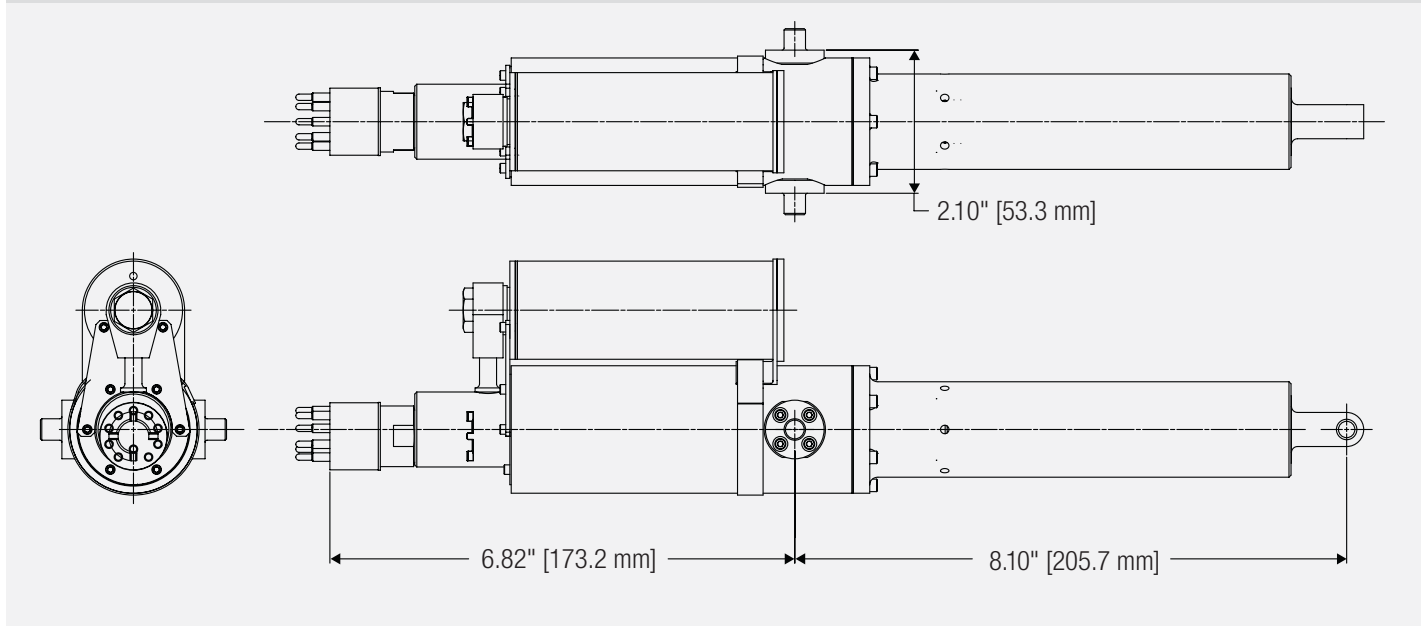

# MOOG

### AMERICAS

navalsystems@moog.com  
www.moog.com/defense



Moog Space and Defense

### AUSTRALIA

Info.australia@moog.com  
www.moog.com.au



Moog Inc.



@Moog\_Inc

### EUROPE

defenceurope@moog.com  
www.moog.com/defence



@Moog.Inc

The appearance of U.S. Department of Defense (DoD) visual information does not imply or constitute DoD endorsement.

Equipment described herein falls under the jurisdiction of the ITAR and requires US Government Authorization for export purposes. Diversion contrary to US law is prohibited.

©2024 Moog, Inc. All rights reserved.

Product and company names listed are trademarks or trade names of their respective companies.