

# MOOG

## G631K/D631K Series Installation and Operation Instruction Electrohydraulic Servovalve Intrinsic Safety Protected



### 1. INTRODUCTION

This manual provides instructions and procedures necessary to install, operate and troubleshoot the Moog Series G631K/D631K series intrinsic safety protected Industrial Servovalve. Troubleshooting instructions are outlined to permit the identification of the specific component(s) suspected of failure.

The G631K/D631K series valves are electrical equipment for hazardous areas with intrinsic safety protection. Identification  $\text{Ex}$  II 1G Ex ia IIC T6 or T5 CESI 02ATEX109 X,  $\text{CE}$  nnnn (see product label, Ex. 0344). They are intended for directional, position, velocity, pressure and force control in hydraulic control systems that operate with mineral oil based fluids. Others upon request.

### 2. OPERATION

The Moog G631K/D631K Series Industrial Servovalve consists of a polarized electrical torque motor and two stages of hydraulic power amplification. The motor armature extends into the air gaps of the magnetic flux circuit and is supported in this position by a flexure tube member. The flexure tube acts as a seal between the electromagnetic and hydraulic sections of the valve. The two motor coils surround the armature, one on each side of the flexure tube.



The flapper of the first stage hydraulic amplifier is rigidly attached to the midpoint of the armature. The flapper extends through the flexure tube and passes between two nozzles, creating two variable orifices between the nozzle tips and the flapper. The pressure controlled by the flapper and nozzle variable orifice is fed to the end areas of the second stage spool.

The second stage is a conventional 4-way spool design in which output flow from the valve, at a fixed valve pressure drop, is proportional to spool displacement from the null position. A cantilever feedback spring is fixed to the flapper and engages a hole at the center of the spool. Displacement of the spool deflects the feedback spring which creates a force on the armature/flapper assembly.

Input signal induces a magnetic charge in the armature and causes a deflection of the armature and flapper. This assembly pivots about the flexure tube, and increases the size of one nozzle orifice and decreases the size of the other.

This action creates a differential pressure from one end of the spool to the other and results in spool displacement. The spool displacement transmits a force to the feedback wire which opposes the original input signal torque. Spool movement continues until the feedback wire force equals the input signal force.

### ELECTROHYDRAULIC VALVE CUT-AWAY

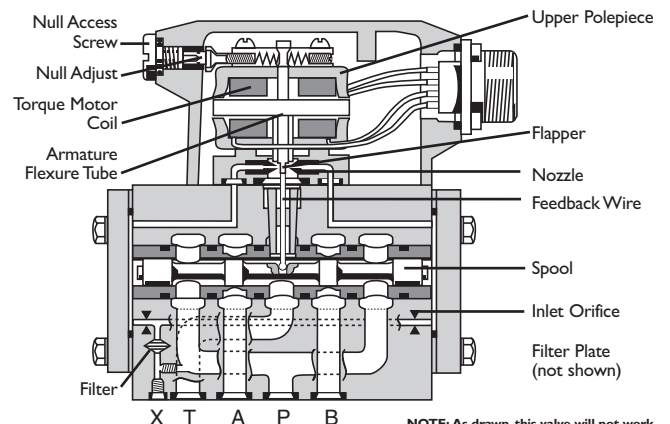

NOTE: As drawn, this valve will not work.

### CAUTION

DISASSEMBLY, MAINTENANCE, OR REPAIR OTHER THAN IN ACCORDANCE WITH THE INSTRUCTIONS HEREIN OR OTHER SPECIFIC WRITTEN DIRECTIONS FROM MOOG WILL INVALIDATE MOOG'S OBLIGATIONS UNDER ITS WARRANTY AND INTRINSICALLY SAFE PROTECTION PERMIT NULL AND VOID.

Figure 1 Moog Series G631K/D631K

### 3. ELECTRICAL INFORMATION AND INTRINSICALLY SAFE CIRCUIT SAFETY PARAMETERS

- The electrical torque motor coil leads are attached to the valve connector so external connections can provide series, parallel or single coil operation. Refer to installation drawings of the specific models for details. Servovalve coils should be driven with current to provide consistency throughout the temperature range.
- The G631K/D631K valves are approved for Intrinsically safe protection per EN 60079-11. The approved safety parameters are listed in the following table.

Coil Configuration	Safe Parameters		
	U <sub>i</sub> (V)	I <sub>i</sub> (mA)	P <sub>i</sub> (W)
Single Coil	6.2	400	.62
Parallel Coil	6.2	400	.62
Series Coils	13	200	.65

- When making electric connections to the valve, appropriate measures must be taken to ensure that locally different earth potentials do not result in excessive ground currents. When barriers are required for the hazardous location, hazardous area (field) wiring must meet the requirements of the barrier manufacturer. All barriers must be mounted and installed in compliance with the barrier manufacturer's requirements. Twisted pairs of 18-20 gage wire are recommended. If shielded wire is used, connect shield wire to earth ground only at the barrier strip.

### 4. SPECIAL CONDITIONS FOR SAFE USE

Because the enclosure of the apparatus is made of aluminum, if it is mounted in an area where the use of category I G apparatus is required, it must be installed such that even in the event of rare incidents, ignition sources due to impact and friction sparks are excluded.

The screwed cable connector may only be disconnected when the circuit is de-energized or when the location is known to be non-hazardous.

When used at an ambient temperature  $\geq 70^{\circ}\text{C}$ , heat resistant cable must be used with a continuous operating temperature in accordance with the application.

### 5. HYDRAULIC SYSTEM PREPARATION

To prolong servovalve operational life and to reduce hydraulic system maintenance, it is recommended that the hydraulic fluid be kept at a cleanliness level of ISO DIS 4406 code 16/13 maximum, 14/11 recommended. The most effective filtration scheme uses a kidney loop or "off-line" filtration. The filter for the "off-line" filtration should be a  $\beta_3 \geq 75$  filter for maximum effectiveness.

Upon system startup and prior to mounting the servovalve, the entire hydraulic system should be purged of built-in contaminating particles by an adequate flushing. The servovalve should be replaced by a flushing manifold and the hydraulic circuit powered up under conditions of fluid temperature and fluid velocity, reasonably simulating normal operating conditions. New system filters are installed during the flushing process whenever the pressure drop across the filter element becomes excessive. The flushing processes should turn over the fluid in the reservoir between fifty to one hundred times.

To maintain a clean hydraulic system, the filters must be replaced on a periodic basis. It is best to monitor the pressure drop across the filter assembly and replace the filter element when the pressure drop becomes excessive. In addition to other filters that are installed in the hydraulic circuit, it is recommended that a large capacity, low pressure  $\beta_3 \geq 75$  filter be installed in the return line. This filter will increase the interval between filter element replacements and greatly reduce the system contamination level.

### 6. INSTALLATION

The Moog G631K/D631K Series Servovalves may be mounted in any position, provided the servovalve pressure, control and return ports match respective manifold ports. The mounting pattern and port location of servovalve are shown on Figure 4. Apply a light film of oil to the mounting screw threads and torque the screws to 96 inch-pounds.

Wire mating connector for desired coil configuration and polarity. Thread connector to valve.

### 7. MECHANICAL NULL ADJUSTMENT

It may be desirable to adjust the servovalve for flow null independent of other system parameters. The mechanical null adjustment permits convenient control function set-ups.

The mechanical null adjuster is a hex socket set screw located behind the pan head screw in the motor cap (see Figure 2) which, when adjusted, provides control of the spool position to obtain the desired flow null.

**NORMAL ADJUSTMENT SHOULD REQUIRE LESS THAN  $\pm$  ONE TURN.  
LIMIT NULL SCREW ADJUSTMENT TO LESS THAN  $\pm$  TWO TURNS.**

#### Adjustment Procedure

- Using a blade screwdriver, remove the null access screw to permit adjustment of the hex socket set screw.
- Using a  $1/8$  inch Allen Wrench, adjust the set screw to obtain the desired flow null.

**Note:** Clockwise rotation of the set screw produces flow out port A.

- After the desired flow null has been obtained, replace the null access screw.

#### Tools and Equipment

- Blade screwdriver
- Allen wrench ( $1/8$  inch)

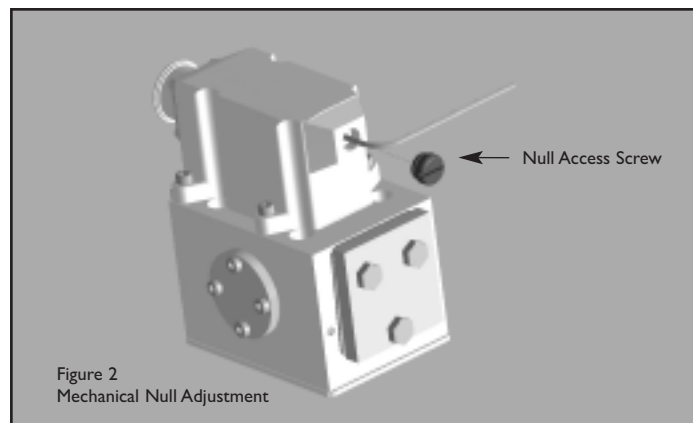

Figure 2  
Mechanical Null Adjustment

### 8. GENERAL SERVICING RECOMMENDATIONS

- Disconnect the electrical lead to the servovalve.
- Relieve the hydraulic system of residual pressure.
- Remove the servovalve.

## 9. TROUBLESHOOTING CHART

The following troubleshooting chart lists potential troubles encountered, probable causes, and remedies.

Potential Trouble	Probable Cause	Remedy
Servo valve does not follow input command signal. (Actuator or components are stationary or creeping slowly).	Plugged inlet filter element	Replace filter element
High threshold. (Jerky, possible oscillatory or "hunting" motion in closed loop system).	Plugged filter element	Replace filter element
Poor response. (Servo valve output lags electrical command signal).	Partially plugged filter element	Replace filter element
High null bias (High input current required to maintain hydraulic cylinder or motor stationary).	1. Incorrect null adjustment 2. Partially plugged filter element	1. Readjust null 2. Replace filter element and check for dirty hydraulic fluid in system

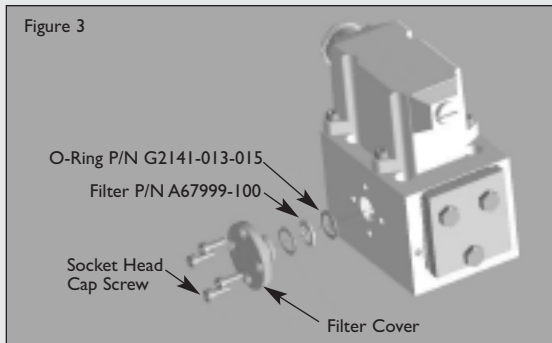

**Table I. Replacement Parts**

Part Description	Qty.	Part Number
G631K/D631K Filter Replacement Kit	1	B52555RK200K001
Filter O-Ring	2	G2141-013-015
Filter	1	A67999-100
Base O-Ring	5	G2141-012-020
Base O-Ring	1	G2141-008-020

(1) Included in Filter Replacement Kit

## 10. FILTER ASSEMBLY REPLACEMENT

Tools and Equipment

- a. 3mm Allen wrench
  - b. Torque wrench
- a. Remove the four socket head capscrews and lockwashers with 3mm Allen wrench.
  - b. Remove the filter retainer.
  - c. Remove and discard the filter disk.
  - d. Remove and replace the O-Ring on the filter retainer and the O-Ring in the filter bore.
  - e. Reinstall in reverse order; torque screws to 38-40 in-lbs.

## 11. AUTHORIZED REPAIR FACILITIES

Moog does not authorize any facilities other than Moog or Moog subsidiaries to repair its servo valves. It is recommended you contact Moog at (716) 652-2000 to locate your closest Moog repair facility. Repair by an independent (unauthorized) repair house will result in voiding the Moog warranty and could lead to performance degradation or safety problems.

## 12. DECLARATION OF MANUFACTURER

A Declaration of Manufacturer according to EN 60079-0, EN 60079-11 and EN 60079-26 is available for G631K /D631K series valves and will be supplied upon request.

# G631K/D631K SERIES INSTALLATION AND OPERATION INSTRUCTION

## NOTES

### 1 Fluid:

Industrial type petroleum base hydraulic fluid, maintained to ISO DIS 4406 Code 14/11 recommended.

### 2 Operating Temperature Range:

-20°F [-29°C] to +275°F [+135°C]

### 3 Valve Phasing:

Flow out port B results when:  
Series coils: B & C connected, A+, D-;  
Parallel coils: A & C connected, B & D connected, A+, D-.

### 4 Surface:

Surface to which valve is mounted requires  $\nabla$  finish, flat within 0.001 [0.03] TIR.

### 5 Null Adjust:

Flow out Port A results with clockwise rotation of null adjust set screw (1/8 hex key).

### 6 Mounting Manifold:

Must conform to ISO 4401-05-05-0-94\*

\*Note: Location of X port in valve body does **not** correspond to ISO standards.

### 7 Mounting Bolts:

#### (Socket Head Cap Screws)

1/4-20 NC x 2 3/4 long  
(Moog PN A31324-144B)

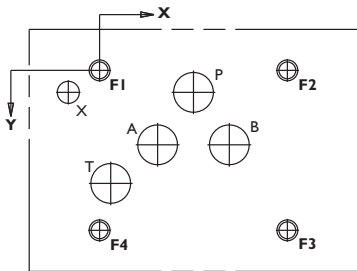
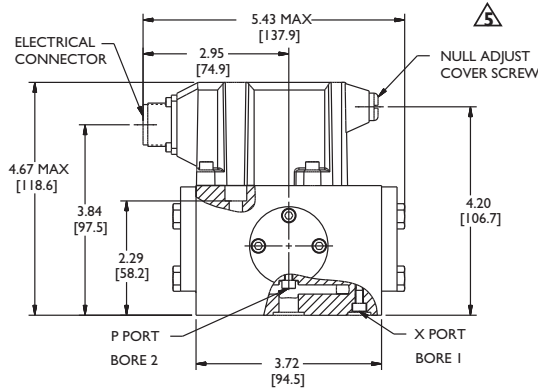
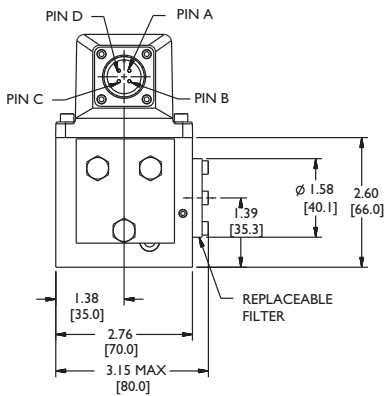
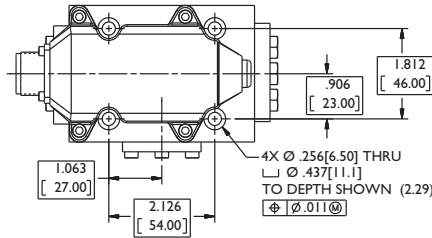

U.S.	P	A	B	T	X	F1	F2	F3	F4
	Ø.44	Ø.44	Ø.44	Ø.44	Ø.125	1/4 - 20	1/4 - 20	1/4 - 20	1/4 - 20
X	1.06	0.66	1.47	0.13	-0.35	0	2.13	2.13	0
Y	0.25	0.84	0.84	1.28	0.25	0	0	1.81	1.81

METRIC	P	A	B	T	X	F1	F2	F3	F4
	Ø11.2	Ø11.2	Ø11.2	Ø11.2	Ø3.2	M6	M6	M6	M6
X	27	16.7	37.3	3.2	-9	0	54	54	0
Y	6.3	21.4	21.4	30.5	6.3	0	0	46.0	46.0

## TYPICAL WIRING SCHEMATIC

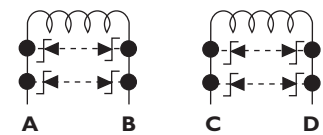

Figure 4

## CONVERSION INSTRUCTION

For operation with internal or external pilot connection.

	Pilot flow supply	Set screw (M4 X 6 DIN 912)
Internal P	Internal P	bore 1
External X	External X	bore 2
		closed
		open
		open
		closed

# MOOG

Industrial Controls Division

Moog Inc., East Aurora, NY 14052-0018

Telephone: 716/652-2000

Fax: 716/687-7910

Toll Free: 1-800-272-MOOG

www.moog.com/industrial