

CARTRIDGE COVERS

ISO 7368 SIZES 16 TO 100

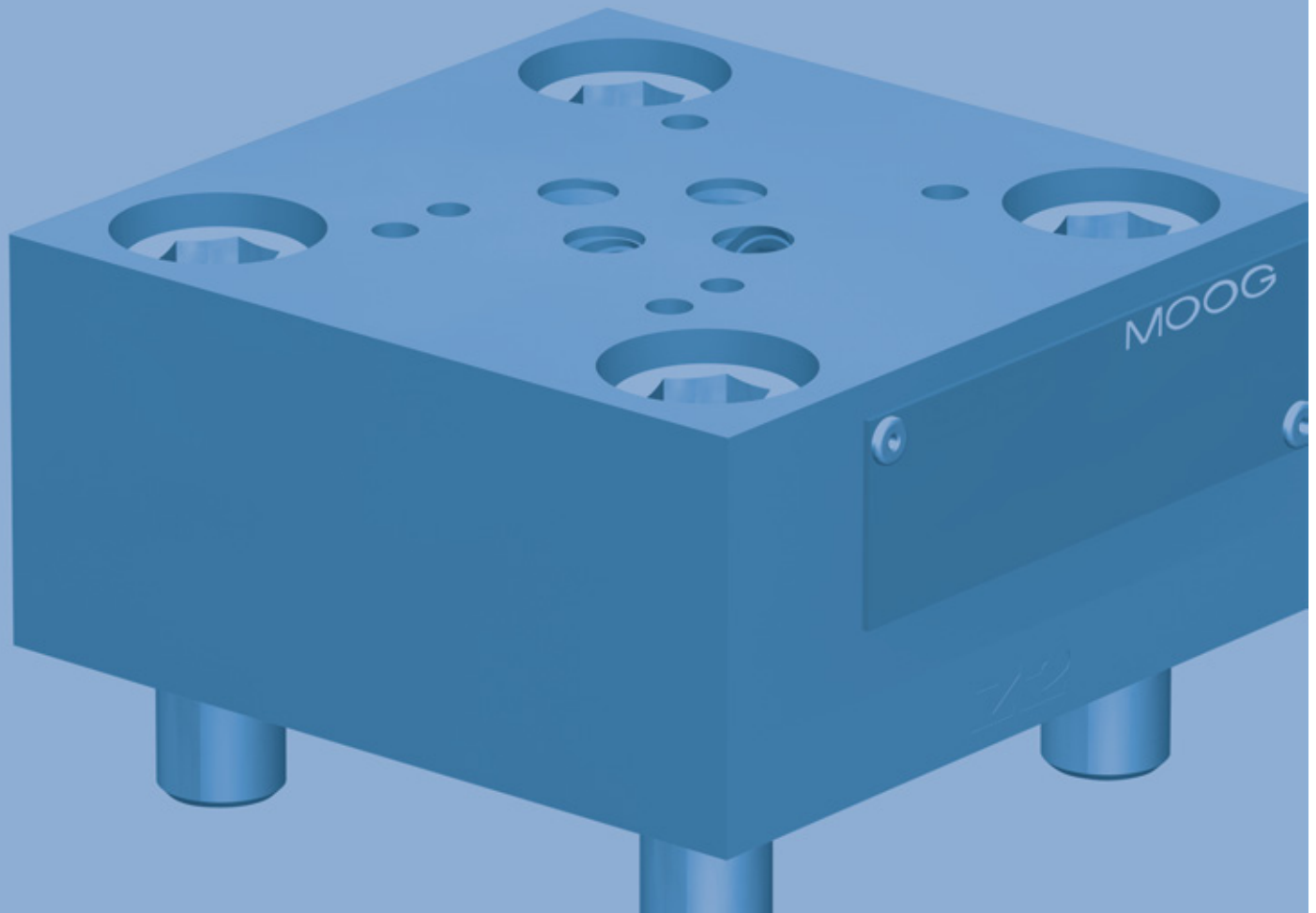

Rev. A, December 2014

DESIGNED FOR OPERATING PRESSURES UP TO
420 BAR (6,000 PSI)

Whenever the highest levels of motion control performance and design flexibility are required, you'll find Moog expertise at work. Through collaboration, creativity and world-class technological solutions, we help you overcome your toughest engineering obstacles. Enhance your machine's performance. And help take your thinking further than you ever thought possible.

INTRODUCTION.....	2
Product Overview	3
Description of Operation	5
TECHNICAL DATA	7
General Technical Data.....	7
1D Cover	8
1H Cover	12
RM Cover.....	18
DRE Cover	22
1W Cover	26
1WDB Cover.....	30
2D Cover	34
2W Cover	38
2WR Cover.....	42
4W Cover.....	46
RV Cover	50
BACKGROUND	54
Orifice Installation Options in the Cover.....	54
Installation Dimensions.....	56
ORDERING INFORMATION.....	58
Accessories and Spare Parts.....	58
Moog Global Support.....	59
Ordering Code	61



This catalog is for users with technical knowledge. To ensure all necessary characteristics for function and safety of the system, the user has to check the suitability of the products described herein. The products described herein are subject to change without notice. In case of doubt, please contact Moog.

Moog is a registered trademark of Moog Inc. and its subsidiaries. All trademarks as indicated herein are the property of Moog Inc. and its subsidiaries. For the full disclaimer refer to www.moog.com/literature/disclaimers.

For the most current information, visit www.moog.com/industrial or contact your local Moog office.

PRODUCT OVERVIEW

The Moog Cartridge Valve Covers featured in this catalog are designed for Moog's 2-way Slip-in Cartridge Valves (CEE series). These valves offer the highest nominal flows and lowest pressure drops available on the market (see cartridge catalog for more details). Additionally, the covers can also be used with most Moog Slip-in Cartridge Valves (CKE, CEHFE and previous CEE series) which are designed according to ISO 7368.

The rated pressure of the covers is up to 420 bar (6,000 psi), depending on cover type and seal material. State-of-the-art development techniques were used to optimize the cover design for this rated pressure. This results in reliable performance in even the most extreme load applications.

The cover series offers a variety of directional, flow and pressure control functions. Due to the integration of check and shuttle valves as well as interfaces for subplate pilot valves, a compact system design even for complex functions can be achieved.

11 different cover types are available for the nominal diameters (sizes) 16, 25, 32, 40, 50, 63, 80 and 100 mm according to ISO 7368. Each cover type can be equipped with different seals for use with a wide variety of operating fluids.

Cartridge Valves and Covers in use

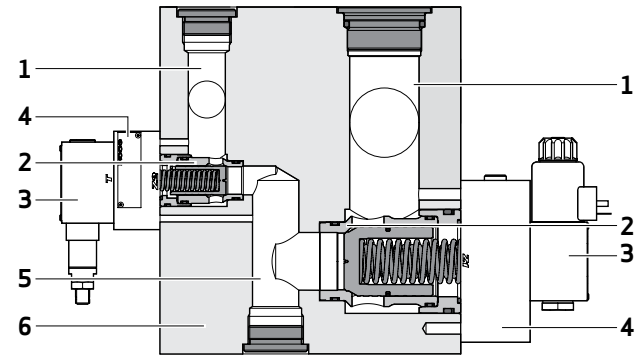

- 1 B port
- 2 Cartridge valve
- 3 Pilot valve
- 4 Cover
- 5 A port
- 6 Manifold

Features	Benefits
Robust design for a nominal pressure up to 420 bar (6,000 psi)	Highest load capability, even for applications in extreme environments
Extremely reliable and durable design	High degree of system availability
Covers for directional, flow and pressure control functions for all sizes	Wide selection of functions for maximum flexibility in manifold design
Covers can be combined with most Moog 2-way Slip-in Cartridge Valves (CEE, CKE and CEHFE series)	Maximum flexibility during system and manifold design
Integrated check and shuttle valves as well as interfaces for subplate pilot valves	Compact system design even for most complex functions

PRODUCT OVERVIEW

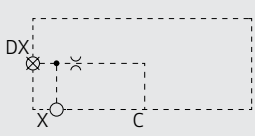
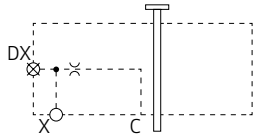
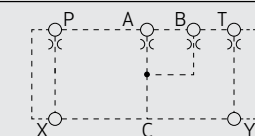
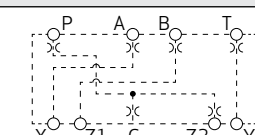
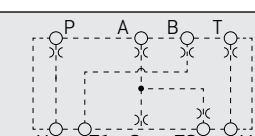
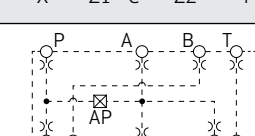
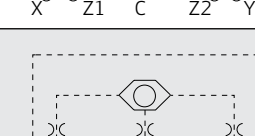
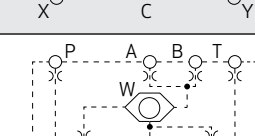
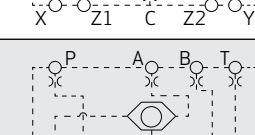
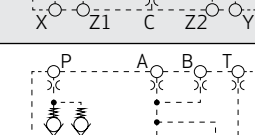
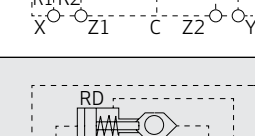
Cover	Preferred function	Sizes	Max. Pressure [bar (psi)]/Seal material			
			NBR	NBR+PU	FKM+PU	FKM
1D 	Cover with remote control port for directional and check function	16 to 100	420 (6000)	420 (6000)	350 (5000)	350 (5000)
1H 	Cover with remote control port and stroke limiter for directional, check, manual shut-off and manual throttle functions	16 to 100	420 (6000)	420 (6000)	350 (5000)	350 (5000)
RM 	Cover with mounting pattern for a directional control valve. Can be used for both directional and pressure functions	16 to 100	420 (6000)	420 (6000)	350 (5000)	350 (5000)
DRE 	Cover with mounting pattern for a pressure control valve. Can be used for more complex pressure functions requiring multiple pilot valves	16 to 100	420 (6000)	420 (6000)	350 (5000)	350 (5000)
1W 	Cover with mounting pattern for a directional control valve. The additional control port can be used for a second cartridge valve. For directional and pressure functions	16 to 100	420 (6000)	420 (6000)	350 (5000)	350 (5000)
1WDB 	Cover with mounting pattern for directional and pressure control valves for pressure functions with multiple pilot valves	16 to 100	420 (6000)	420 (6000)	350 (5000)	350 (5000)
2D 	Cover with integrated shuttle valve for directional control and check functions using the maximum of two pressures	16 to 100	420 (6000)	420 (6000)	350 (5000)	-
2W 	Cover with integrated shuttle valve for use as a pilot-operated check valve circuit. With mounting pattern for a directional control valve	16 to 100	420 (6000)	420 (6000)	350 (5000)	-
2WR 	Cover with integrated shuttle valve for use as a pilot-operated check valve circuit. With mounting pattern for a directional control valve	16 to 100	420 (6000)	420 (6000)	350 (5000)	-
4W 	Cover with mounting pattern for a directional control valve with built in check valves. For functions where a maximum of two pilot pressures is desired	16 to 63	420 (6000)	420 (6000)	350 (5000)	350 (5000)
		80 to 100	420 (6000)	420 (6000)	350 (5000)	-
RV 	Cover for pilot-operated check valve function, with remote control port	16 to 100	-	350 (5000)	350 (5000)	-

DESCRIPTION OF OPERATION

Operating Principle for Directional Function

In order to successfully create a directional function for an application it is important to understand the basic operating principles of a directional cartridge valve in combination with a cartridge cover.

A directional function requires, first of all, a cartridge valve with a B, C, E or F poppet (6). These poppets all have a stepped shape resulting in 3 different control surfaces. A control surface for the A (7), B (5) and C (2) ports.

Second, a cartridge cover (1) is necessary to control the sum of the forces applied to each of these control surfaces. Pressure applied to the surfaces at A and B will work to open the valve; pressure applied to the surface at C will work to close the valve. Should little or no pressure be present, the force of the spring (3) will hold the valve closed.

In the example of the 1D cover shown, the X port supplies the pressure working to close the valve. If X is connected to the tank, there is only the spring force remaining to close the valve. This results in a bi-directional function where the flow direction is $A \rightarrow B$ or $B \rightarrow A$.

If the X port is connected to the A or B port of the cartridge valve, then the pressure in X will close the valve and the flow from $A \rightarrow B$ or $B \rightarrow A$ respectively will be blocked.

Directional Cartridge Valve and Cover

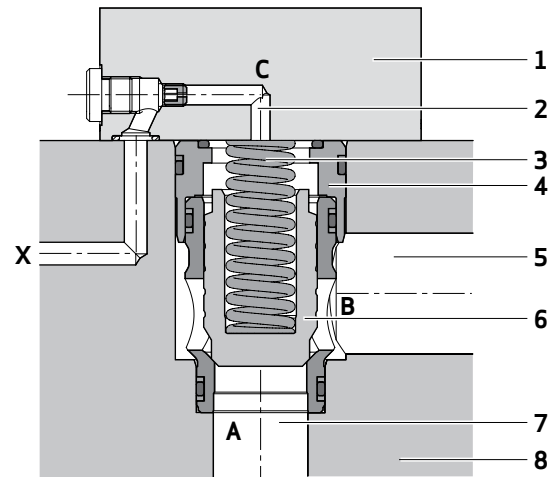

- 1 Cover
- 2 Control port C
- 3 Spring
- 4 Sleeve and cap
- 5 B port
- 6 Poppet
- 7 A port
- 8 Manifold

DESCRIPTION OF OPERATION

Operating Principle for Pressure Function

Pressure relief valves and covers are vital components of any hydraulic system. Together, these components are used to limit the maximum permissible hydraulic pressure where necessary.

Typical applications include limiting pump and cylinder pressures. The limiting of cylinder pressures not only protects the cylinder from damage, but also enables the reliable control of the force applied by the cylinder.

In combination with a cover and a pilot valve, both manual and electrical proportional pressure settings can be realized with or without relief functionality. In order to get the most out of these functions, it is important to understand the basic operating principles of a pressure cartridge and cover.

The A0 and EX poppets used in pressure functions have no or only a small control surface at port B. Leaving only 2 primary control surfaces, surface A working to open the valve, and surface X together with the spring force working to close the valve.

The pressure to be limited is applied to port A (9) and is also routed simultaneously to port C (4) of the cover (3) and the pilot valve (1) via a pilot line (11) equipped with a suitable metering orifice. If the pressure in port A exceeds the present pressure setting of the pilot valve, the pilot valve opens venting the pressure at port C. The pressure compensated poppet (8) then opens against the spring force (5) and set pressure, limiting the pressure at port A.

When ordering components for a pressure function, it is important to note that it is also possible to enhance the functionality of a cover (e.g., a depressurizing function or additional pressure stages) by using additional sandwich plate valves.

For pressure reducing and compensating functions Moog offers the DMO series of 2-way Slip-in Cartridge Valves with a spool design. Please refer to the catalog for more information.

Pressure Cartridge Valve and Cover

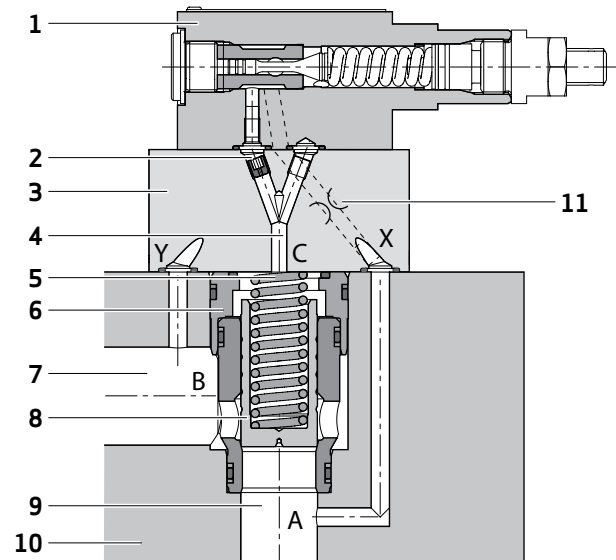

- 1 Pilot valve, pressure relief
- 2 Damping orifice
- 3 Cover
- 4 C port
- 5 Spring
- 6 Sleeve and cap
- 7 B port
- 8 Poppet
- 9 A port
- 10 Manifold
- 11 X port with metering orifice

GENERAL TECHNICAL DATA

General Technical Data

Mounting type	Manifold mounting
Installation position	Any
Mounting pattern	ISO 7368:1989-08
Storage temperature range	
Cover with FKM seals	-20 to +80 °C (-4 to 176 °F)
Cover with NBR seals	-30 to +80 °C (-22 to 176 °F)
Ambient temperature range	
Cover with FKM seals	-20 to +80 °C (-4 to 176 °F)
Cover with NBR seals	-30 to +80 °C (-22 to 176 °F)
MTTF_d value according to EN ISO 13849-1	150 years

Hydraulic Data

Maximum operating pressure ¹⁾	350 bar (5,000 psi), respectively 420 bar (6,000 psi)
Seal material/hydraulic fluid combination	
FKM	<ul style="list-style-type: none"> Mineral oil based hydraulic fluids HFD hydraulic fluids
FKM + PU	<ul style="list-style-type: none"> Mineral oil based hydraulic fluid
NBR	<ul style="list-style-type: none"> Mineral oil based hydraulic fluid HFB, HFC hydraulic fluids
NBR + PU	<ul style="list-style-type: none"> Mineral oil based hydraulic fluid
Temperature range of hydraulic fluid	
Cover with FKM seals	-20 to +80 °C (-4 to 176 °F)
Cover with NBR seals	-30 to +80 °C (-22 to 176 °F)
Recommended viscosity range	15 to 46 mm ² /s (cSt)
Maximum permissible viscosity range	2.8 to 380 mm ² /s (cSt)
Recommended cleanliness class as per ISO 4406	
For functional safety	20/18/15
For longer service life	17/14/11

1) See the product overview table on page 4

1D COVER

Functional Description

The 1D cover can be used in combination with a cartridge¹⁾ to create both check and directional functions; depending on how the X port of the cover is connected.

Directional Function

If the X port of the cover is connected to tank, then flow is enabled in both directions from A → B and B → A. Whereas, if the X port is connected to sufficient pilot pressure, flow will be blocked in both directions.

Check Function

If the X port of the cover is connected to the B port of the cartridge, a check function is created with the flow direction being only A → B. The flow in the other direction, B → A is blocked.

1) Cartridge with a B, C, E or F poppet.

Directional Function

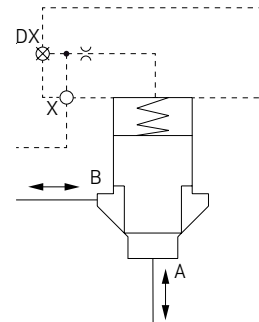

Check Function

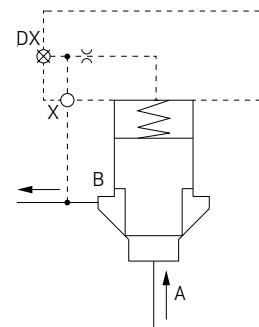

Hydraulic Symbol

Sizes 16 to 100

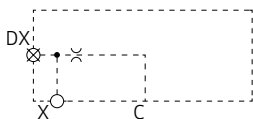

1D COVER

Orifice Configuration

The 1D cover is equipped with a single orifice in X that can be accessed from the outer side of the cover. This orifice is used to limit the flow to and from the C port of the cover and thereby limit the opening and closing rate of the cartridge.

For assistance with orifice configuration please contact Moog.

Preferred Type (NBR)

Size	Ordering code without orifice	Ordering code with standard orifice	Orifice code ¹⁾
16	XEB18534-000N01	XEB18534-004N01	X15
25	XEB18516-000N01	XEB18516-003N01	X15
32	XEB18498-000N01	XEB18498-005N01	X25
40	XEB18440-000N01	XEB18440-005N01	X30
50	XEB18422-000N01	XEB18422-005N01	X35
63	XEB18330-000N01	XEB18330-005N01	X35
80	XEB18307-000N01	XEB18307-002N01	X40
100	XEB18292-000N01	XEB18292-002N01	X40

1) See ordering code (position 12) on page 63.

Cover Details

Size	16	25	32	40	50	63	80	100
Orifice details	See page 55							
Spare parts	See page 58							
Mounting screws	See table for mounting screws on page 58							
Plug DX, MX	G1/8"	G1/8"	G1/4"	G1/4"	G1/4"	G3/8"	G1/2"	G1/2"
Hex key size [mm]	5	5	6	6	6	8	10	10
Torque [Nm (lbf ft)]	12 (9)	12 (9)	27 (20)	27 (20)	27 (20)	56 (41)	72 (53)	72 (53)
Weight [kg (lb)]	1.1 (2.43)	1.7 (3.75)	3.1 (6.84)	6.3 (13.89)	8.2 (18.08)	17 (37.49)	27 (59.54)	43 (94.82)

1D COVER

Sizes 16 to 63

Cover Dimensions

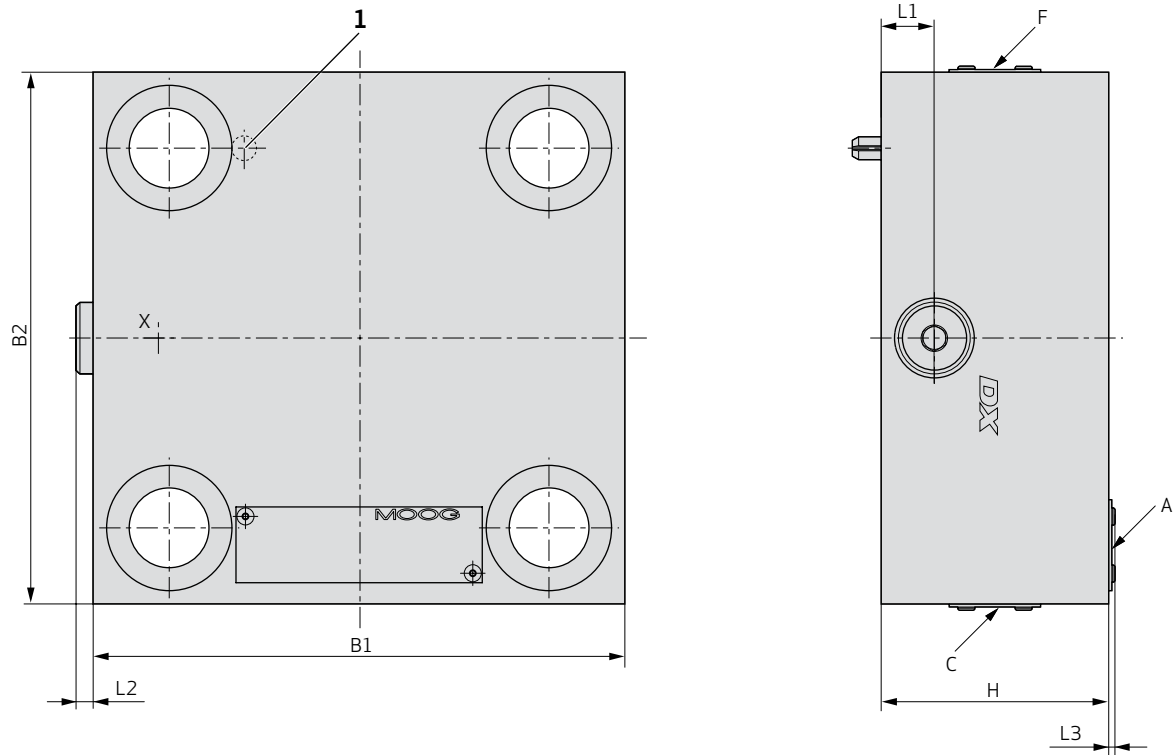

1 Locating pin

Size	16	25	32	40	50	63
B1 [mm (in)]	65 (2.56)	85 (3.35)	102 (4.02)	125 (4.92)	140 (5.51)	180 (7.09)
B2 [mm (in)]	65 (2.56)	85 (3.35)	102 (4.02)	125 (4.92)	140 (5.51)	180 (7.09)
H [mm (in)]	35 (1.38)	35 (1.38)	45 (1.77)	60 (2.36)	60 (2.36)	80 (3.15)
L1 [mm (in)]	17 (0.67)	12 (0.47)	21 (0.83)	20 (0.79)	14 (0.55)	27 (1.06)
L2 [mm (in)]	3.5 (0.14)	3.5 (0.14)	4.5 (0.18)	4.5 (0.18)	4.5 (0.18)	4.5 (0.18)
L3 [mm (in)]	1.5 (0.06)	1.5 (0.06)	1.5 (0.06)	1.5 (0.06)	1.5 (0.06)	1.5 (0.06)
Nameplate position	A	C	F	C	A	A
ISO 7368 mounting pattern	BA-06-2-A	BB-08-2-A	BC-09-2-A	BD-10-2-A	BE-11-2-A	BF-12-2-A

1D COVER

Sizes 80 to 100

Cover Dimensions

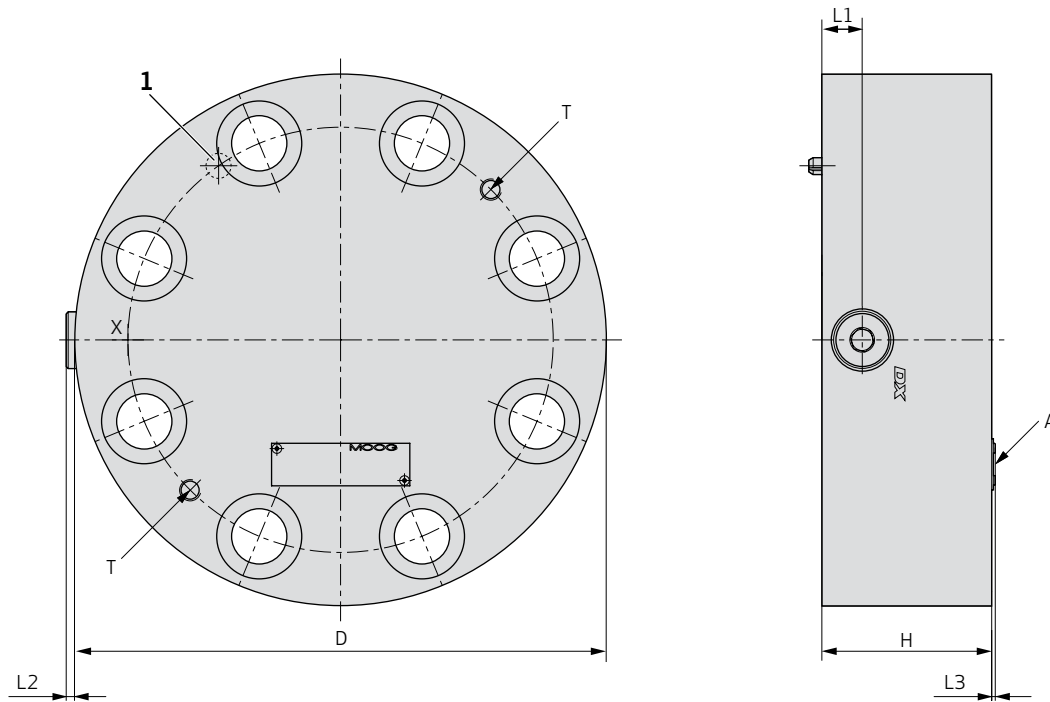

1 Locating pin

Size	80	100
D [mm (in)]	250 (9.84)	300 (11.81)
H [mm (in)]	80 (3.15)	90 (3.54)
L1 [mm (in)]	19 (0.75)	18 (0.71)
L2 [mm (in)]	4 (0.16)	4 (0.16)
L3 [mm (in)]	1.5 (0.06)	1.5 (0.06)
Nameplate position	A	A
ISO 7368 mounting pattern	BG-13-2-A	BH-14-2-A
T - (eye-bolt thread)	M10	M10

1H COVER

Functional Description

The 1H cover can be used in combination with a cartridge¹⁾ for both check and directional functions depending on how the X port is connected. The 1H is also equipped with a stroke limiter for use in throttling applications.

Directional Function

If the X port of the cover is connected to tank, then flow is enabled in both directions from A → B and B → A. Whereas, if the X port is connected to sufficient pilot pressure, flow will be blocked in both directions.

Check Function

If the X port of the cover is connected to the B port of the cartridge, a check function is created with the flow direction being only A → B. The flow in the other direction, B → A is blocked.

Throttle Function

The adjustable stroke limiter on the 1H cover allows the flow to be throttled manually in both directions. Please note: The stroke limiter can only be adjusted to a limited extent while under pressure. The covers are not intended to be used for manual shut-off functions.

1) Cartridge with a B, C, E or F poppet.

Directional and Throttle Function

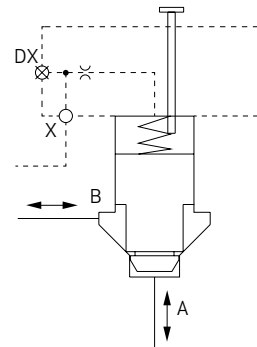

Check Function

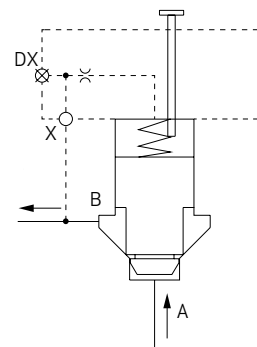

Hydraulic Symbol

Sizes 16 to 100

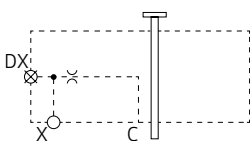

1H COVER

Compatible Cartridge Valves

Due to the nature of the 1H cover design, it is important to ensure that this cover is used with the correct cartridge series and poppet type.

The 1H cover in this catalog is only to be used with Moog 2-way Slip-in Cartridge Valves for directional function (Series K6):

- B poppet: all versions
- C poppet: all versions
- E poppet: versions with no internal orifice
- F poppet: versions with no internal orifice

This 1H cover is incompatible with the following Moog 2-way Slip-in Cartridge Valves:

- A poppet: all versions
- E poppet: versions with an internal orifice
- F poppet: versions with an internal orifice

Other cartridge types, such as another Moog cartridge series or cartridges from other suppliers, are incompatible with this 1H cover.

Assembly Instructions

For sizes 32-100, the 1H cover is delivered with a cartridge poppet insert (1).

This insert is designed to fit between the spring and the poppet, as shown, and is essential to the 1H cover function.

Adjustment Options

Adjustment 2:
1H covers ordered with "Adjustment 2" are delivered without a tamper proof cap set.

Adjustment 9:
1H covers ordered with "Adjustment 9" are delivered with a tamper proof cap set. This set is provided unassembled with the cover and is to be installed by the end user. The set consists of a cap (2), cap screw (3), a wire (4) and a tamper proof seal (5).

Adjustment 2

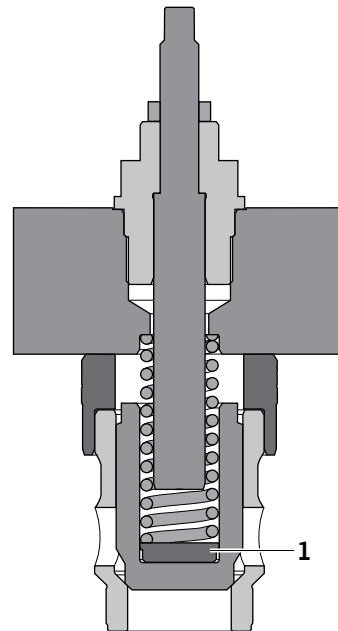

1 Poppet insert

Adjustment 9

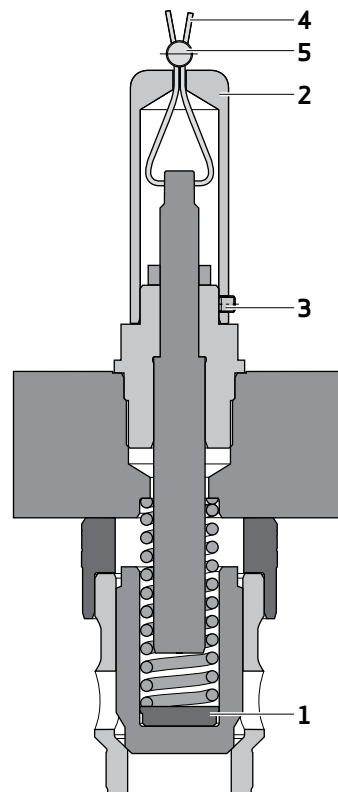

1 Poppet insert
2 Cap
3 Cap screw
4 Wire
5 Tamper proof seal

1H COVER

Orifice Configuration

The 1H cover is equipped with a single orifice in X that can be used to limit the flow to and from the C port of the cover and thereby limit the opening and closing rate of the cartridge.

For assistance with orifice configuration please contact Moog.

Preferred Type (NBR, Adjustment 2)

1H Cover	Ordering code without orifice	Ordering code with standard orifice	Orifice code ¹⁾
16	XEB19288-200N01	XEB19288-201N01	X15
25	XEB19289-200N01	XEB19289-201N01	X15
32	XEB19290-200N01	XEB19290-201N01	X25
40	XEB19291-200N01	XEB19291-201N01	X30
50	XEB19292-200N01	XEB19292-201N01	X35
63	XEB19293-200N01	XEB19293-201N01	X35
80	XEB19294-200N01	XEB19294-201N01	X40
100	XEB19295-200N01	XEB19295-201N01	X40

1) See ordering code (position 12) on page 63.

Cover Details

Size	16	25	32	40	50	63	80	100
Orifice details	See page 55							
Spare parts	See page 58							
Mounting screws	See table for mounting screws on page 58							
Plug DX, MX	G1/8"	G1/8"	G1/4"	G1/4"	G1/4"	G3/8"	G1/2"	G1/2"
Hex key size [mm]	5	5	6	6	6	8	10	10
Torque [Nm (lbf ft)]	12 (9)	12 (9)	27 (20)	27 (20)	27 (20)	56 (41)	72 (53)	72 (53)
Stroke adjustment SW1								
Wrench size [mm]	8	8	8	13	13	17	21	27
Lock nut SW2								
Wrench size [mm]	19	19	19	27	27	46	46	55
Torque [Nm (lbf ft)]	65 (48)	65 (48)	65 (48)	85 (63)	85 (63)	150 (111)	150 (111)	175 (129)
Cap screw SW3								
Hex key size [mm]	2.5	2.5	2.5	2.5	2.5	2.5	-	-
Torque [Nm (lbf ft)]	5 (4)	5 (4)	5 (4)	5 (4)	5 (4)	5 (4)	-	-
Spindle guide SW4								
Wrench size [mm]	36	36	36	36	36	65	65	80
Torque [Nm (lbf ft)]	110 (81)	110 (81)	110 (81)	150 (111)	150 (111)	350 (258)	350 (258)	410 (302)
Weight [kg (lb)]	1.7 (3.75)	2.4 (5.29)	3.6 (7.94)	7.3 (16.1)	9.13 (20.13)	19.3 (42.56)	29 (63.95)	54.3 (119.73)

1H COVER

Size 16 to 25

Cover Dimensions

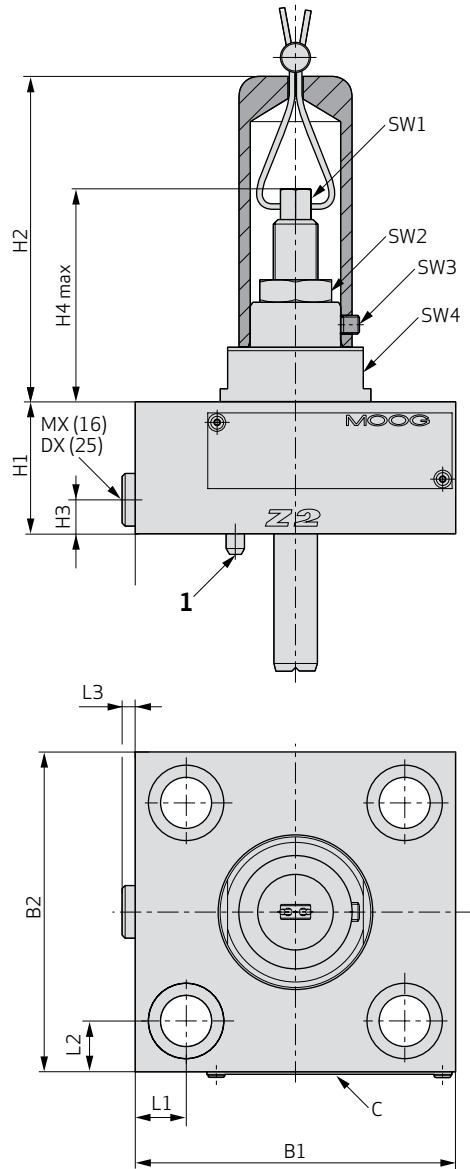

1 Locating pin

Size	16	25
B1 [mm (in)]	65 (2.56)	85 (3.35)
B2 [mm (in)]	65 (2.56)	85 (3.35)
H1 [mm (in)]	35 (1.38)	35 (1.38)
H2 [mm (in)]	86.5 (3.41)	86.5 (3.41)
H3 [mm (in)]	9 (0.35)	9 (0.35)
H4 _{max} [mm (in)]	56.5 (2.22)	56.5 (2.22)
L1 [mm (in)]	9.5 (0.37)	13.5 (0.53)
L2 [mm (in)]	9.5 (0.37)	13.5 (0.53)
L3 [mm (in)]	3.5 (0.14)	3.5 (0.14)
Nameplate position	C	C
ISO 7368 mounting pattern	BA-06-2-A	BB-08-2-A

1H COVER

Sizes 32 to 63

Cover Dimensions

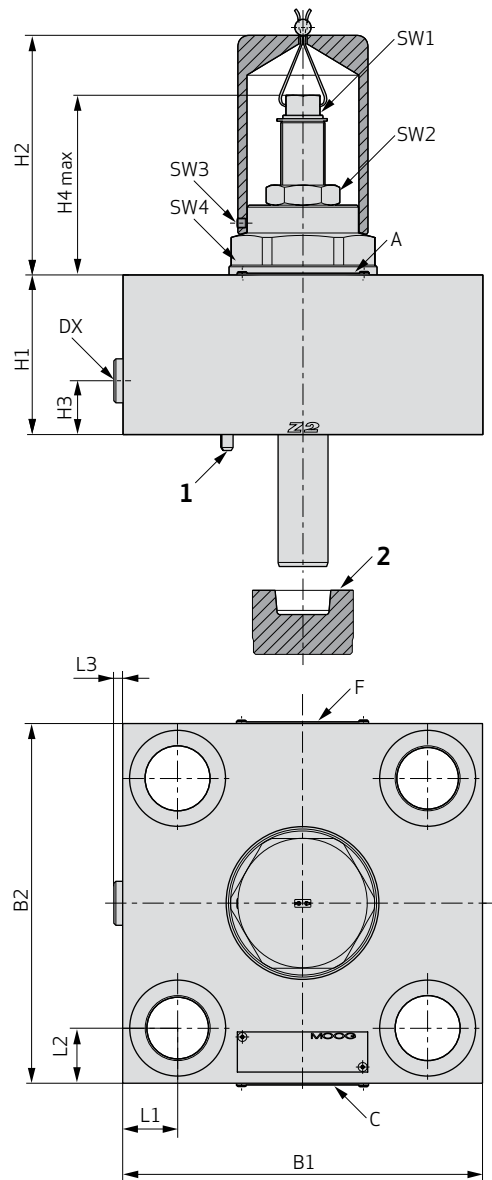

- 1 Locating pin
- 2 Poppet insert

Size	32	40	50	63
B1 [mm (in)]	102 (4.02)	125 (4.92)	140 (5.51)	180 (7.09)
B2 [mm (in)]	102 (4.02)	125 (4.92)	140 (5.51)	180 (7.09)
H1 [mm (in)]	45 (1.77)	60 (2.36)	60 (2.36)	80 (3.15)
H2 [mm (in)]	86.5 (3.41)	83.5 (3.29)	74 (2.91)	120 (4.72)
H3 [mm (in)]	21 (0.83)	20 (0.79)	14 (0.55)	27 (1.06)
H4_{max} [mm (in)]	62 (2.44)	71 (2.8)	64 (2.52)	90 (3.54)
L1 [mm (in)]	16 (0.63)	20 (0.79)	20 (0.79)	27.5 (1.08)
L2 [mm (in)]	16 (0.63)	20 (0.79)	20 (0.79)	27.5 (1.08)
L3 [mm (in)]	4.5 (0.18)	4.5 (0.18)	4.5 (0.18)	4.5 (0.18)
Nameplate position	F	C	A	A
ISO 7368 mounting pattern	BC-09-2-A	BD-10-2-A	BE-11-2-A	BF-12-2-A

1H COVER

Sizes 80 to 100

Cover Dimensions

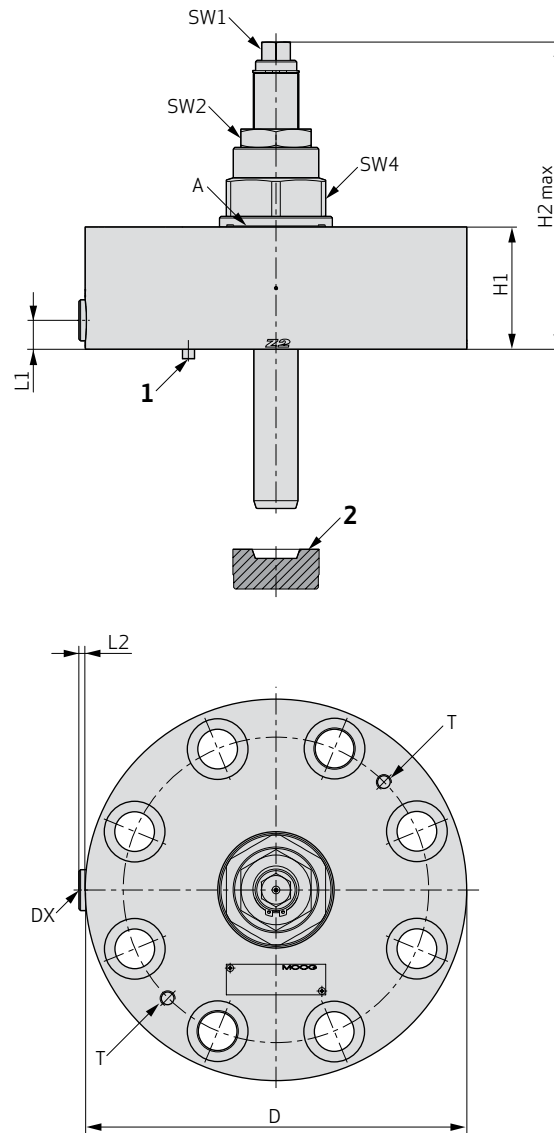

- 1 Locating pin
- 2 Poppet insert

Size	80	100
D [mm (in)]	250 (9.84)	300 (11.81)
H1 [mm (in)]	80 (3.15)	90 (3.54)
H2 _{max} [mm (in)]	117 (4.61)	152 (5.98)
L1 [mm (in)]	19 (0.75)	18 (0.71)
L2 [mm (in)]	4 (0.16)	4 (0.16)
Nameplate position	A	A
ISO 7368 mounting pattern	BG-13-2-A	BH-14-2-A
T - (eye-bolt thread)	M10	M10

RM COVER

Functional Description

The RM cover is a versatile cover that can be used for both pressure and directional functions depending on the type of pilot valve used:

Pilot-Operated Directional Function

When using an RM cover in combination with a cartridge¹⁾ and a control valve²⁾, a bi-directional function or a check function can be achieved depending on the state of the solenoid.

When the solenoid is energized, and there is a plug in port B of the cover, then the spring chamber of the cartridge is connected to tank. This enables flow over the cartridge in both directions: From A → B and from B → A.

When the solenoid is de-energized; then the spring chamber is subject to the pilot pressure from control port X of the cover. For example, if this pilot pressure is drawn from the A side of the cartridge, then flow from A to B is blocked; and vice versa when the pilot pressure is drawn from B.

If the plug in the RM cover is installed in port A instead of port B, then the functions with respect to an energized and a de-energized solenoid are reversed.

Pilot-Operated Pressure Relief Function

An RM cover can also be used in combination with a cartridge³⁾ and a pressure pilot valve⁴⁾. A more detailed description of a pressure function using an RM cover can be found in the description of operation section on page 6.

- 1) Cartridge with a B, C, E or F poppet.
- 2) Control valve: A size 03 directional control valve for cover sizes up to 50 or a size 05 directional control valve for cover sizes 63 to 100.
- 3) Cartridge with an A or E poppet.
- 4) For example, a direct-operated pressure relief valve.

Pilot-Operated Directional Function

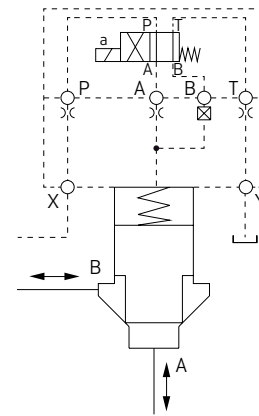

Pilot-Operated Pressure Relief Function

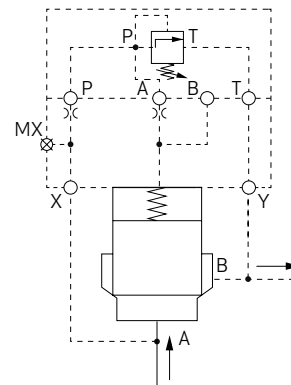

Hydraulic Symbol

Sizes 16 to 25

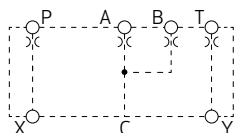

Sizes 32 to 50

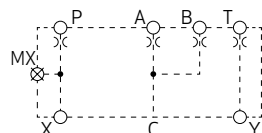

Sizes 63 to 100

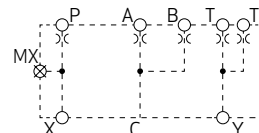

RM COVER

Orifice Configuration

The orifice configurations possible with this cover are numerous and depend on the pilot valve used and the function desired. For more assistance with orifice configurations please contact Moog.

Preferred Type (NBR)

Size	Ordering code without orifice	Ordering code with standard orifice	Orifice code ¹⁾
16	XEB18540-000N01	upon request	-
25	XEB18527-000N01	upon request	-
32	XEB18504-000N01	upon request	-
40	XEB18445-000N01	upon request	-
50	XEB18427-000N01	upon request	-
63	XEB18335-000N01	upon request	-
80	XEB18312-000N01	upon request	-
100	XEB18297-000N01	upon request	-

1) See ordering code (position 12) on page 63.

Cover Details

Size	16	25	32	40	50	63	80	100
Orifice details	See page 55							
Spare parts	See page 58							
Mounting screws	See table for mounting screws on page 58							
Plug MX	-	-	G1/8"	G1/4"	G1/4"	G1/4"	G3/8"	G1/2"
Hex key size [mm]	-	-	5	6	6	6	8	10
Torque [Nm (lbf ft)]	-	-	12 (9)	27 (20)	27 (20)	27 (20)	56 (41)	72 (53)
Weight [kg (lb)]	1.3 (2.87)	2 (4.41)	3 (6.62)	6.2 (13.67)	8 (17.64)	17 (37.49)	26 (57.33)	42 (92.61)

RM COVER

Sizes 16 to 63

Cover Dimensions

Sizes 16 to 50

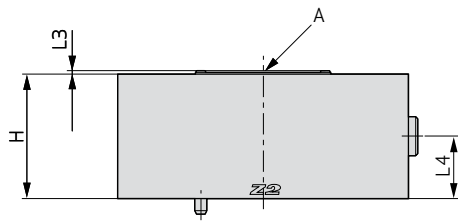

Size 63

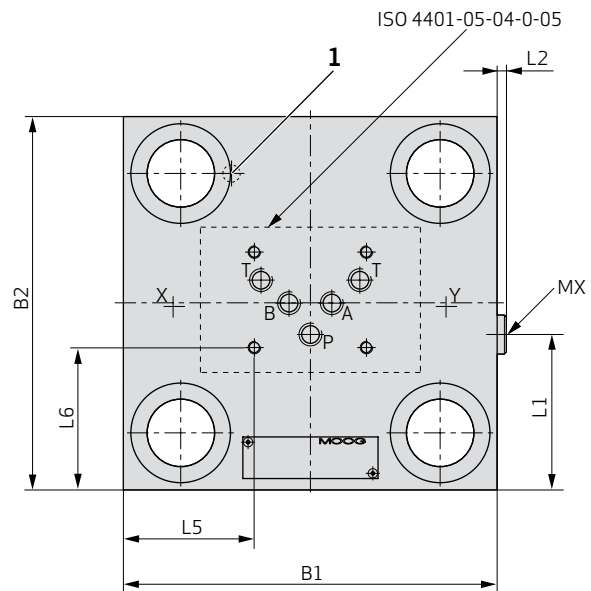
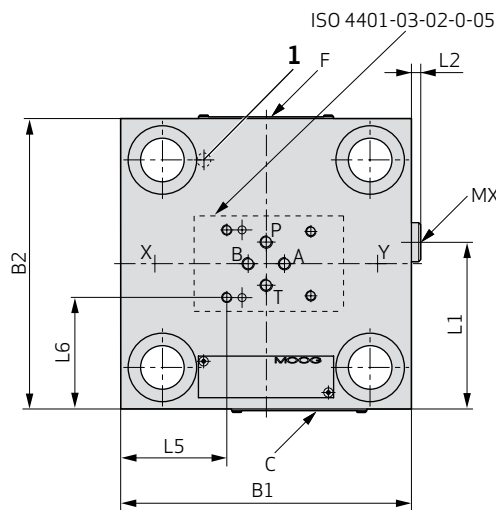
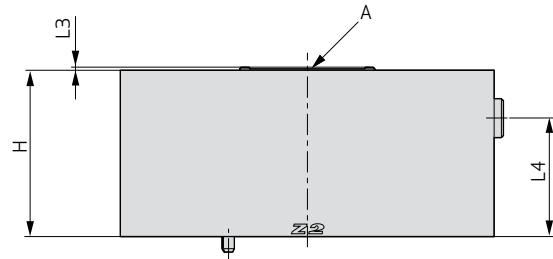

1 Locating pin

Size	16	25	32	40	50	63
B1 [mm (in)]	80 (3.15)	85 (3.35)	102 (4.02)	125 (4.92)	140 (5.51)	180 (7.09)
B2 [mm (in)]	65 (2.56)	85 (3.35)	102 (4.02)	125 (4.92)	140 (5.51)	180 (7.09)
H [mm (in)]	35 (1.38)	40 (1.57)	45 (1.77)	60 (2.36)	60 (2.36)	80 (3.15)
L1 [mm (in)]	-	-	61.3 (2.41)	73 (2.87)	80.4 (3.17)	74.9 (2.95)
L2 [mm (in)]	-	-	3.5 (0.14)	4.5 (0.18)	4.5 (0.18)	4.5 (0.18)
L3 [mm (in)]	1.5 (0.06)	1.5 (0.06)	1.5 (0.06)	1.5 (0.06)	1.5 (0.06)	1.5 (0.06)
L4 [mm (in)]	-	-	27 (1.06)	30 (1.18)	30 (1.18)	57 (2.24)
L5 [mm (in)]	7 (0.28)	23.5 (0.93)	32 (1.26)	43.5 (1.71)	51 (2.01)	63 (2.48)
L6 [mm (in)]	16.25 (0.64)	26.25 (1.03)	34.65 (1.36)	46.25 (1.82)	53.75 (2.12)	68.6 (2.7)
Nameplate position	C	C	F	C	A	A
ISO 7368 mounting pattern	BA-06-2-A	BB-08-2-A	BC-09-2-A	BD-10-2-A	BE-11-2-A	BF-12-2-A

RM COVER

Sizes 80 to 100

Cover Dimensions

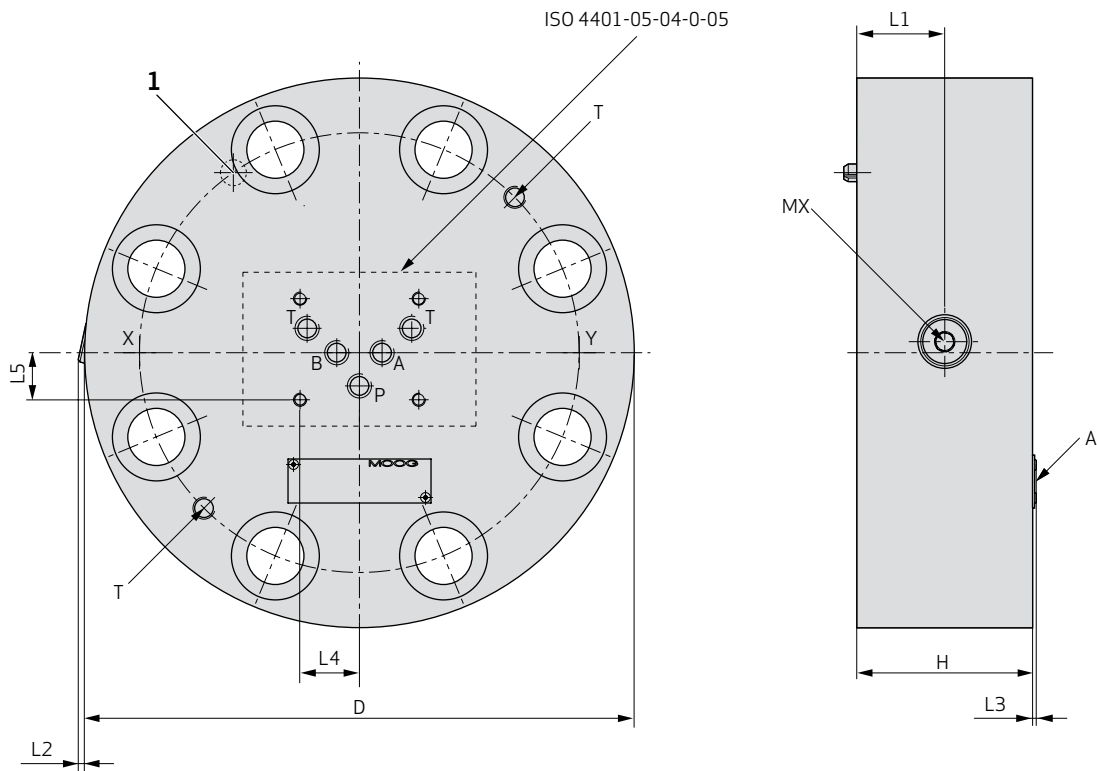

1 Locating pin

Size	80	100
D [mm (in)]	250 (9.84)	300 (11.81)
H [mm (in)]	80 (3.15)	90 (3.54)
L1 [mm (in)]	40 (1.57)	43 (1.69)
L2 [mm (in)]	2.5 (0.1)	2.5 (0.1)
L3 [mm (in)]	1.5 (0.06)	1.5 (0.06)
L4 [mm (in)]	27 (1.06)	27 (1.06)
L5 [mm (in)]	21.4 (0.84)	21.4 (0.84)
Nameplate position	A	A
ISO 7368 mounting pattern	BG-13-2-A	BH-14-2-A
T - (eye-bolt thread)	M10	M10

DRE COVER

Functional Description

The DRE cover is a versatile cover that is used primarily for more complex pressure functions requiring multiple pilot valves:

Pressure Relief and Soft Unloading Function

When using a DRE cover in combination with a pressure cartridge¹⁾, a pressure relief valve²⁾ and a Moog soft unloading control valve³⁾; a pressure relief function or a soft unloading function can be achieved depending upon the state of the solenoid.

When the solenoid is energized, a pressure relief function is created as the pressure from the X port of the DRE cover holds the cartridge closed with a pressure determined by the relief valve.

When the solenoid is de-energized, a very soft and pressure independent unloading function is achieved. When the solenoid is re-energized, the cartridge closes at full speed.

- 1) An AO or EX poppet.
- 2) For example, a direct-operated pressure relief valve.
- 3) Moog WE42P06HMC1P Directional Valve.

Pressure Relief and Soft Unloading Function

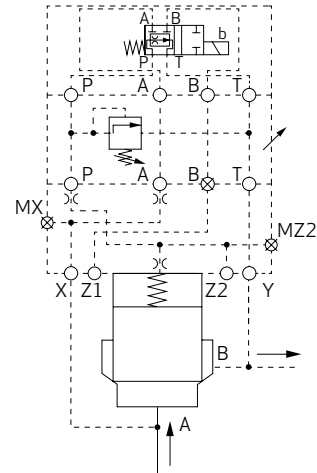

Hydraulic Symbol

Sizes 16 to 25

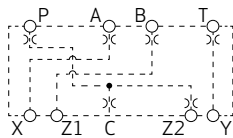

Sizes 32 to 50

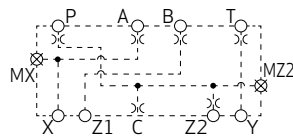

Sizes 63 to 100

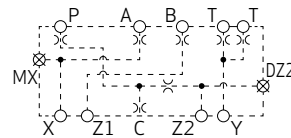

DRE COVER

Orifice Configuration

The orifice configurations possible with this cover are numerous and depend on the pilot valve used and the function desired. For more assistance with orifice configurations please contact Moog.

Preferred Type (NBR)

Size	Ordering code without orifice	Ordering code with standard orifice	Orifice code ¹⁾
16	XEB18544-000N01	upon request	-
25	XEB19263-000N01	upon request	-
32	XEB18511-000N01	upon request	-
40	XEB18452-000N01	upon request	-
50	XEB18434-000N01	upon request	-
63	XEB18342-000N01	upon request	-
80	XEB18467-000N01	upon request	-
100	XEB19274-000N01	upon request	-

1) See ordering code (position 12) on page 63.

Cover Details

Size	16	25	32	40	50	63	80	100
Orifice details	See page 55							
Spare parts	See page 58							
Mounting screws	See table for mounting screws on page 58							
Plug MX, MZ2 + DZ2	-	-	G1/8"	G1/4"	G1/4"	G1/4"	G3/8"	G1/2"
Hex key size [mm]	-	-	5	6	6	6	8	10
Torque [Nm (lbf ft)]	-	-	12 (9)	27 (20)	27 (20)	27 (20)	56 (41)	72 (53)
Weight [kg (lb)]	1.28 (2.82)	1.67 (3.68)	3.08 (6.79)	6.18 (13.63)	9.07 (20)	16.7 (36.82)	26.1 (57.55)	41.8 (92.17)

DRE COVER

Sizes 16 to 63

Cover Dimensions

Sizes 16 to 50

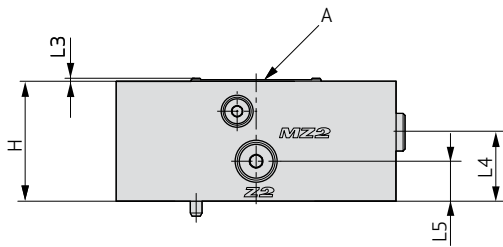

Size 63

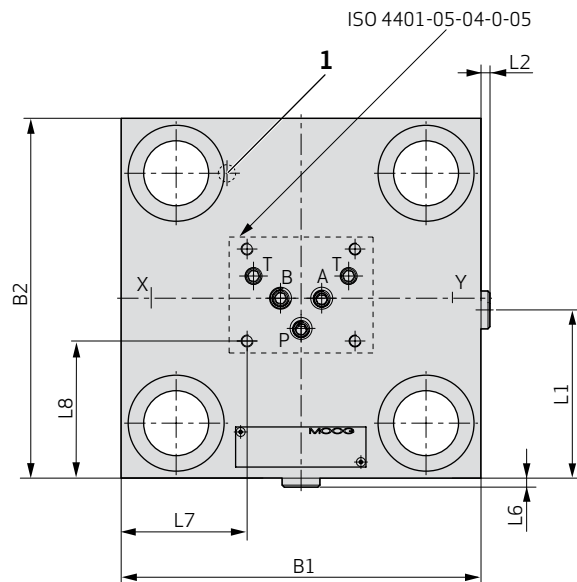
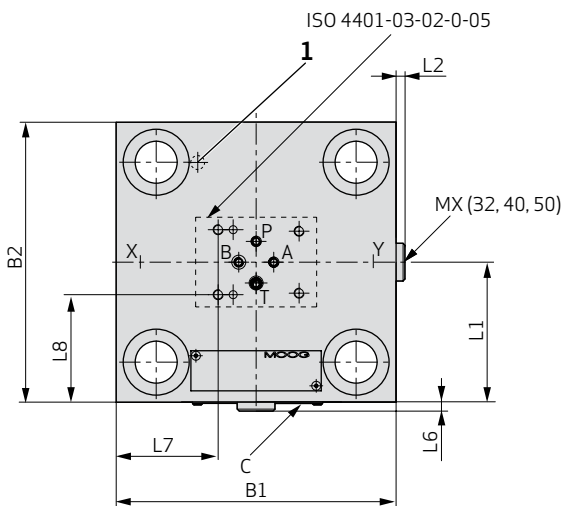
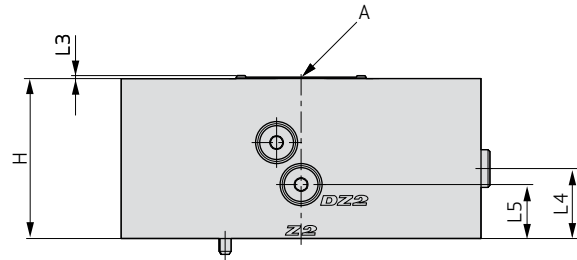

1 Locating pin

Size	16	25	32	40	50	63
B1 [mm (in)]	80 (3.15)	85 (3.35)	102 (4.02)	125 (4.92)	140 (5.51)	180 (7.09)
B2 [mm (in)]	65 (2.56)	85 (3.35)	102 (4.02)	125 (4.92)	140 (5.51)	180 (7.09)
H [mm (in)]	35 (1.38)	35 (1.38)	45 (1.77)	60 (2.36)	60 (2.36)	80 (3.15)
L1 [mm (in)]	-	-	50.9 (2)	62.5 (2.46)	70 (2.76)	84.15 (3.31)
L2 [mm (in)]	-	-	3.5 (0.14)	4.5 (0.18)	4.5 (0.18)	4.5 (0.18)
L3 [mm (in)]	1.5 (0.06)	1.5 (0.06)	1.5 (0.06)	1.5 (0.06)	1.5 (0.06)	1.5 (0.06)
L4 [mm (in)]	-	-	26 (1.02)	33.9 (1.33)	34.5 (1.36)	35 (1.38)
L5 [mm (in)]	-	-	18 (0.71)	22.9 (0.9)	20 (0.79)	27 (1.06)
L6 [mm (in)]	-	-	3.5 (0.14)	4.5 (0.18)	4.5 (0.18)	4.5 (0.18)
L7 [mm (in)]	7 (0.28)	23.5 (0.93)	32 (1.26)	43.5 (1.71)	51 (2.01)	63 (2.48)
L8 [mm (in)]	16.25 (0.64)	26.25 (1.03)	34.65 (1.36)	46.25 (1.82)	53.75 (2.12)	68.6 (2.7)
Nameplate position	C	C	C	C	A	A
ISO 7368 mounting pattern	BA-06-2-A	BB-08-2-A	BC-09-2-A	BD-10-2-A	BE-11-2-A	BF-12-2-A

DRE COVER

Sizes 80 to 100

Cover Dimensions

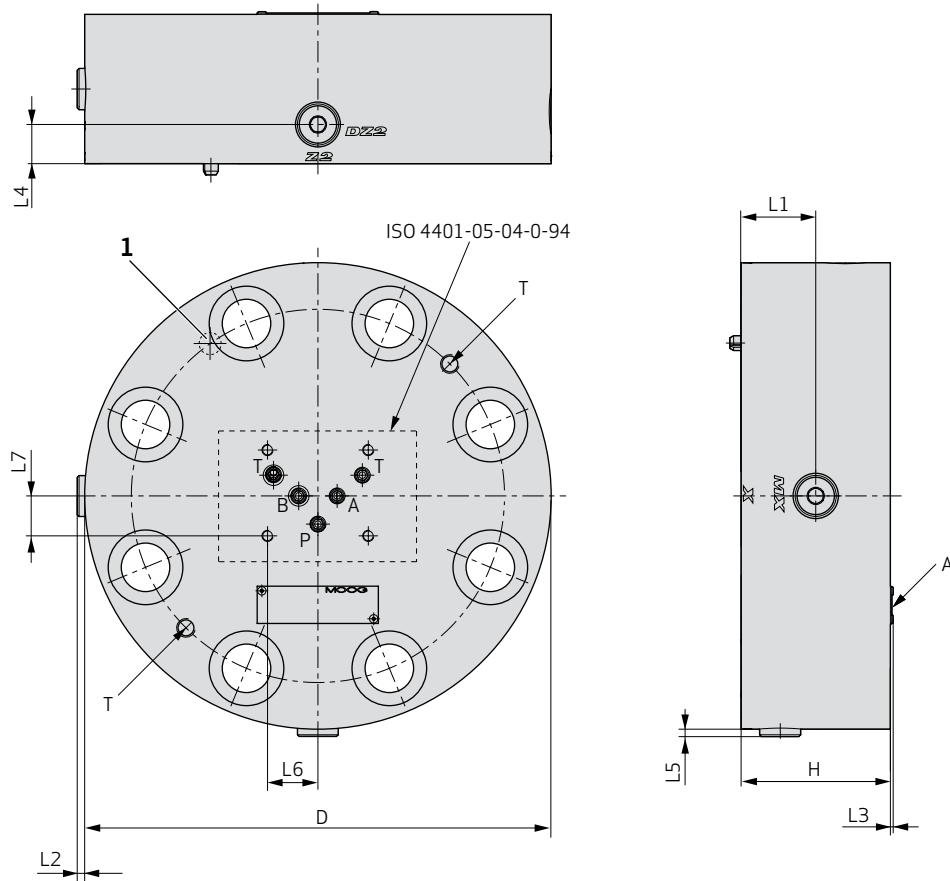

1 Locating pin

Size	80	100
D [mm (in)]	250 (9.84)	300 (11.81)
H [mm (in)]	80 (3.15)	90 (3.54)
L1 [mm (in)]	40 (1.57)	43 (1.69)
L2 [mm (in)]	4 (0.16)	1 (0.04)
L3 [mm (in)]	1.5 (0.06)	1.5 (0.06)
L4 [mm (in)]	21 (0.83)	25 (0.98)
L5 [mm (in)]	4 (0.16)	4 (0.16)
L6 [mm (in)]	27 (1.06)	27 (1.06)
L7 [mm (in)]	21.4 (0.84)	21.4 (0.84)
Nameplate position	A	A
ISO 7368 mounting pattern	BG-13-2-A	BH-14-2-A
T - (eye-bolt thread)	M10	M10

1W COVER

Functional Description

The 1W cover is a versatile cover that can be used for both pressure and directional functions depending on the type of pilot valve used:

Pilot-Operated Directional Function

When using a 1W cover in combination with a cartridge¹⁾ and a control valve²⁾, a bi-directional function or a check function can be achieved depending on the state of the solenoid.

When the solenoid is energized, the spring chamber of the cartridge is connected to tank. This enables flow over the cartridge in both directions: From A → B and from B → A.

When the solenoid is de-energized, the spring chamber is subject to the pilot pressure from control port X of the cover. For example, if this pilot pressure is drawn from the A side of the cartridge, then flow from A to B is blocked; and vice versa when the pilot pressure is drawn from B.

The Z1 or Z2 port can be used in order to activate another cartridge¹⁾.

Pressure Reducing Function

2-way pressure reducing valves are used to reduce a variable input pressure (primary pressure at B) to a lower, constant output pressure (secondary pressure at A).

The reduced pressure can be set using a pressure relief valve on the valve cover. Depending on configuration, this valve can also function as a pressure compensator.

The valves are available as “normally open” or “normally closed” versions. For more detailed information please refer to the Moog pressure reducing valve (DMO series) catalog.

- 1) Cartridge with a B, C, E or F poppet.
- 2) Control valve: A size 03 directional control valve for covers up to size 50 or a size 05 directional control valve for cover sizes 63 to 100.

Pilot-Operated Directional Function

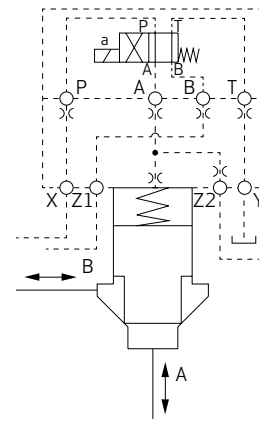

Pressure Reducing Function

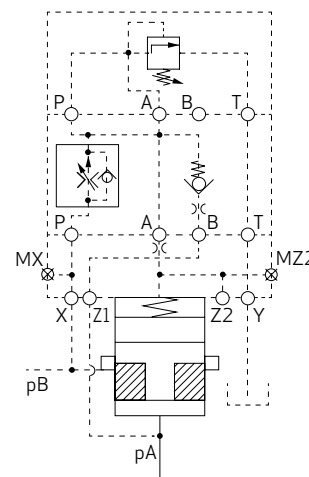

Hydraulic Symbol

Sizes 16 to 25

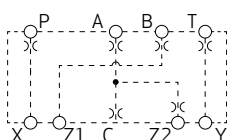

Sizes 32 to 50

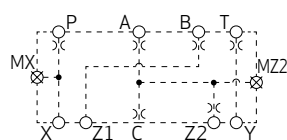

Sizes 63 to 100

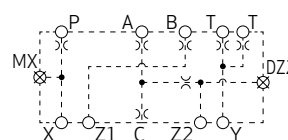

1W COVER

Orifice Configuration

The orifice configurations possible with this cover are numerous and depend on the pilot valve used and the function desired. For more assistance with orifice configurations please contact Moog.

Preferred Type (NBR)

Size	Ordering code without orifice	Ordering code with standard orifice	Orifice code ¹⁾
16	XEB18542-000N01	upon request	-
25	XEB18521-000N01	upon request	-
32	XEB18506-000N01	upon request	-
40	XEB18447-000N01	upon request	-
50	XEB18429-000N01	upon request	-
63	XEB18337-000N01	upon request	-
80	XEB18314-000N01	upon request	-
100	XEB18299-000N01	upon request	-

1) See ordering code (position 12) on page 63.

Cover Details

Size	16	25	32	40	50	63	80	100
Orifice details	See page 55							
Spare parts	See page 58							
Mounting screws	See table for mounting screws on page 58							
Plug MX, MZ2 + DZ2	-	-	G1/8"	G1/4"	G1/4"	G1/4"	G3/8"	G1/2"
Hex key size [mm]	-	-	5	6	6	6	8	10
Torque [Nm (lbf ft)]	-	-	12 (9)	27 (20)	27 (20)	27 (20)	56 (41)	72 (53)
Weight [kg (lb)]	1.3 (2.87)	1.7 (3.75)	3 (6.62)	6.2 (13.67)	8 (17.64)	17 (37.49)	26 (57.33)	42 (92.61)

1W COVER

Sizes 16 to 63

Cover Dimensions

Sizes 16 to 50

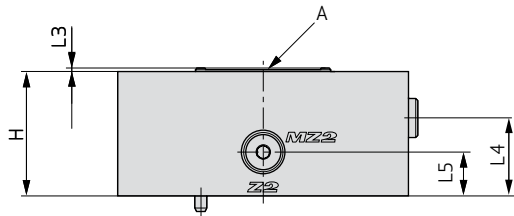

Size 63

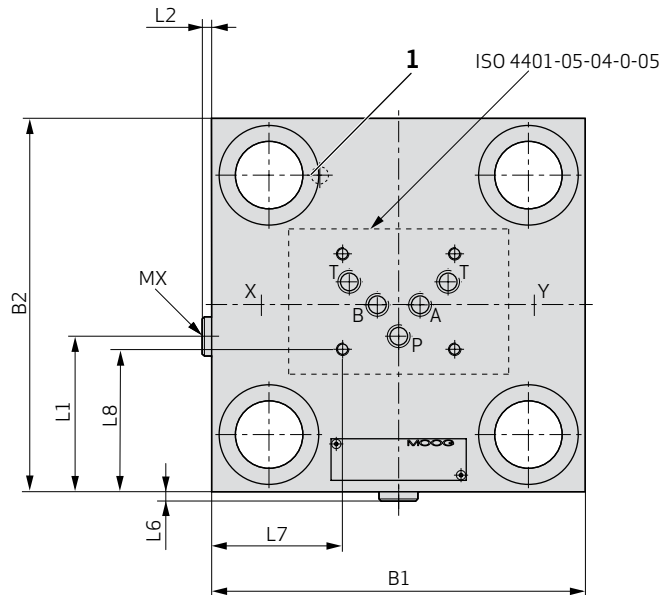
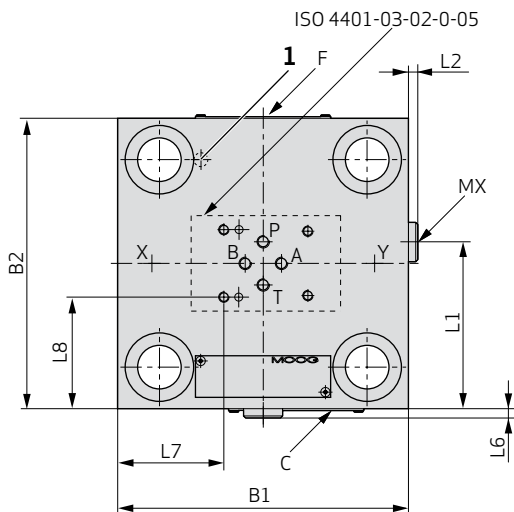
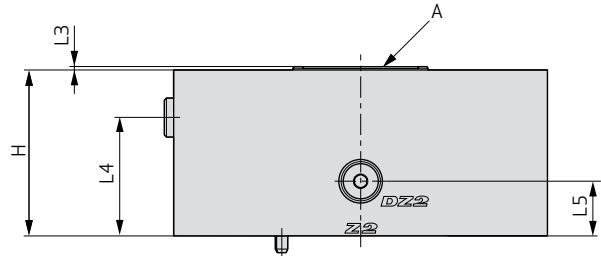

1 Locating pin

Size	16	25	32	40	50	63
B1 [mm (in)]	80 (3.15)	85 (3.35)	102 (4.02)	125 (4.92)	140 (5.51)	180 (7.09)
B2 [mm (in)]	65 (2.56)	85 (3.35)	102 (4.02)	125 (4.92)	140 (5.51)	180 (7.09)
H [mm (in)]	35 (1.38)	35 (1.38)	45 (1.77)	60 (2.36)	60 (2.36)	80 (3.15)
L1 [mm (in)]	-	-	61.3 (2.41)	80 (3.15)	80.4 (3.17)	74.9 (2.95)
L2 [mm (in)]	-	-	3.5 (0.14)	4.5 (0.18)	4.5 (0.18)	4.5 (0.18)
L3 [mm (in)]	1.5 (0.06)	1.5 (0.06)	1.5 (0.06)	1.5 (0.06)	1.5 (0.06)	1.5 (0.06)
L4 [mm (in)]	-	-	26 (1.02)	33.9 (1.33)	37.5 (1.48)	57 (2.24)
L5 [mm (in)]	-	-	15 (0.59)	20 (0.79)	21 (0.83)	26.25 (1.03)
L6 [mm (in)]	-	-	3.5 (0.14)	4.5 (0.18)	4.5 (0.18)	4.5 (0.18)
L7 [mm (in)]	7 (0.28)	23.5 (0.93)	32 (1.26)	43.5 (1.71)	51 (2.01)	63 (2.48)
L8 [mm (in)]	16.25 (0.64)	26.25 (1.03)	34.75 (1.37)	46.25 (1.82)	53.75 (2.12)	68.6 (2.7)
Nameplate position	C	C	F	C	A	A
ISO 7368 mounting pattern	BA-06-2-A	BB-08-2-A	BC-09-2-A	BD-10-2-A	BE-11-2-A	BF-12-2-A

1W COVER

Sizes 80 to 100

Cover Dimensions

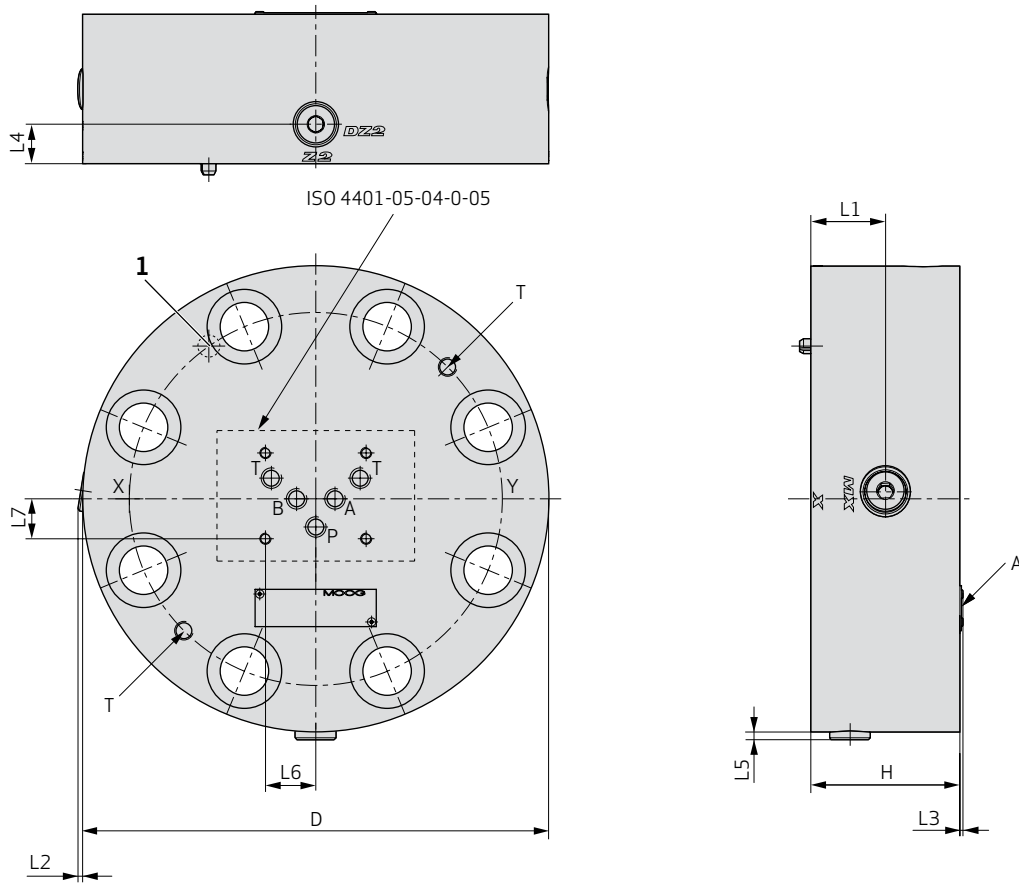

1 Locating pin

Size	80	100
D [mm (in)]	250 (9.84)	300 (11.81)
H [mm (in)]	80 (3.15)	90 (3.54)
L1 [mm (in)]	40 (1.57)	43 (1.69)
L2 [mm (in)]	2.5 (0.1)	2.5 (0.1)
L3 [mm (in)]	1.5 (0.06)	1.5 (0.06)
L4 [mm (in)]	21 (0.83)	25 (0.98)
L5 [mm (in)]	4 (0.16)	4 (0.16)
L6 [mm (in)]	27 (1.06)	27 (1.06)
L7 [mm (in)]	21.4 (0.84)	21.4 (0.84)
Nameplate position	A	A
ISO 7368 mounting pattern	BG-13-2-A	BH-14-2-A
T - (eye-bolt thread)	M10	M10

1WDB COVER

Functional Description

The 1WDB cover is a versatile cover that is used primarily for more complex pressure functions requiring multiple pilot valves:

Pilot-Operated Pressure Relief Function

A two stage pressure relief function is capable of operating at two different preset pressures depending on the state of the solenoid valve. For this function a 1WDB cover in combination with a cartridge¹⁾, two pressure relief sandwich valves²⁾ and a directional pilot valve³⁾ is needed.

When the solenoid is energized, the pressure in the X port of the cover is connected to the secondary pressure relief pilot valve by means of the A port on the solenoid valve. This secondary pilot valve, with a lower pressure relief setting, will override the higher pressure setting of the main pressure relief pilot valve.

When the solenoid is de-energized, the secondary pressure relief valve is no longer part of the circuit. This leaves only the main pressure relief valve with the higher pressure relief setting as active.

- 1) An AO or EX poppet.
- 2) For example, a direct-operated pressure relief valve.
- 3) Control valve: A size 03 directional control valve for covers up to size 50 or a size 05 directional control valve for cover sizes 63 to 100.

Pilot-Operated Pressure Relief Function

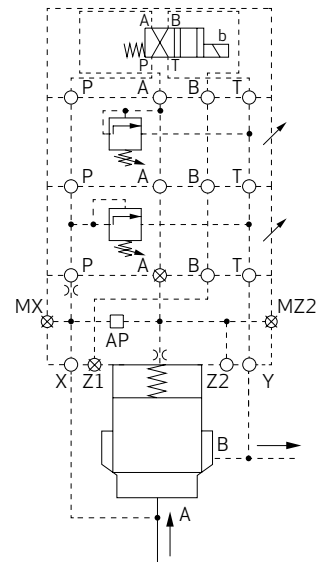

Hydraulic Symbol

Sizes 16 to 25

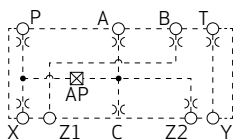

Sizes 32 to 50

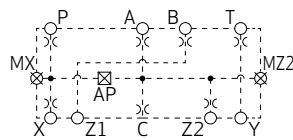

Sizes 63 to 100

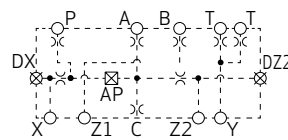

1WDB COVER

Orifice Configuration

The orifice configurations possible with this cover are numerous and depend on the pilot valve used and the function desired. For more assistance with orifice configurations please contact Moog.

Preferred Type (NBR)

Size	Ordering code without orifice	Ordering code with standard orifice	Orifice code ¹⁾
16	XEB18541-000N01	upon request	-
25	XEB18520-000N01	upon request	-
32	XEB18505-000N01	upon request	-
40	XEB18446-000N01	upon request	-
50	XEB18428-000N01	upon request	-
63	XEB18336-000N01	upon request	-
80	XEB18313-000N01	upon request	-
100	XEB18298-000N01	upon request	-

1) See ordering code (position 12) on page 63.

Cover Details

Size	16	25	32	40	50	63	80	100
Orifice details	See page 55							
Spare parts	See page 58							
Mounting screws	See table for mounting screws on page 58							
Plug AP, MX, MZ2 + DZ2	G1/8"	G1/8"	G1/8"	G1/4" ¹⁾	G1/4"	G1/4"	G3/8"	G1/2"
Hex key size [mm]	5	5	5	6	6	6	8	10
Torque [Nm (lbf ft)]	12 (9)	12 (9)	12 (9)	27 (20)	27 (20)	27 (20)	56 (41)	72 (53)
Weight [kg (lb)]	1.27 (2.8)	1.90 (4.19)	3.06 (6.75)	6.16 (13.58)	9.04 (19.93)	16.7 (36.82)	26.0 (57.33)	41.6 (91.73)

1) Port AP G1/8"

1WDB COVER

Sizes 16 to 63

Cover Dimensions

Sizes 16 to 50

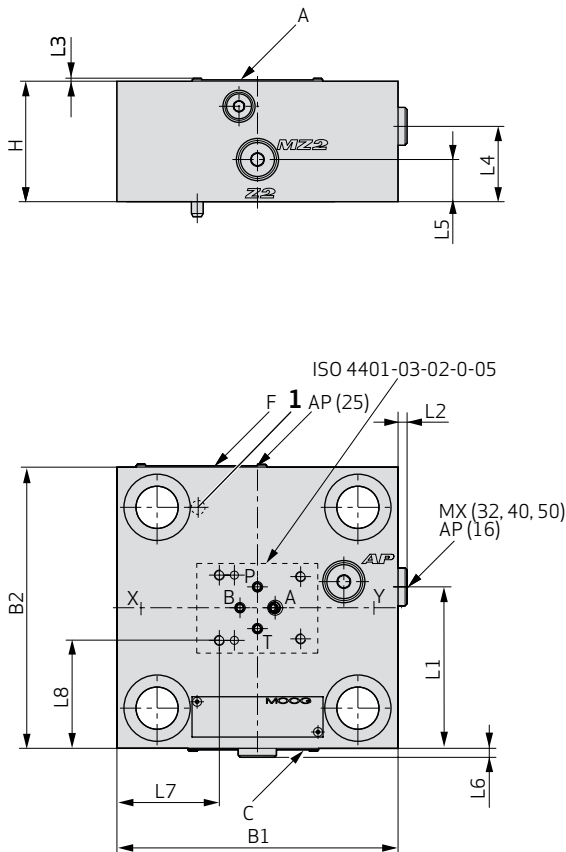

Size 63

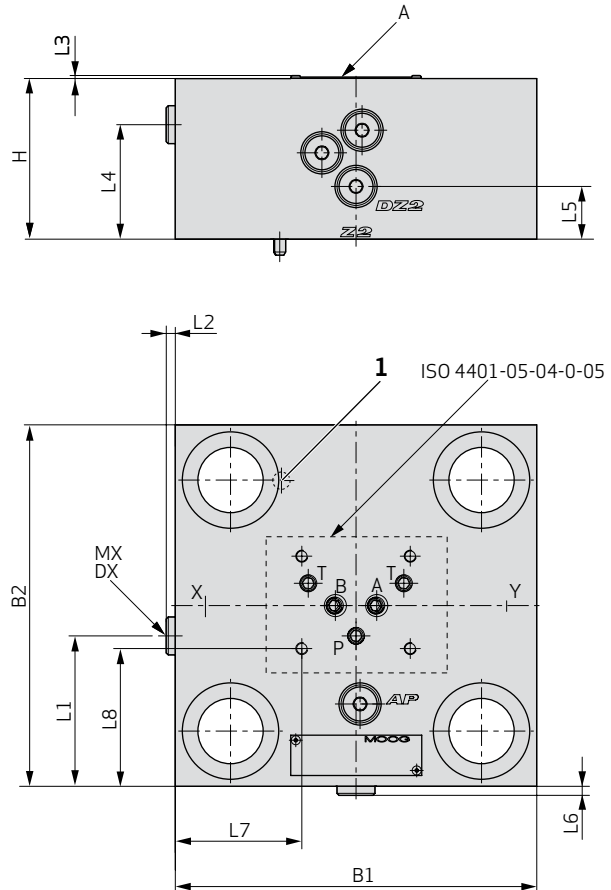

1 Locating pin

Size	16	25	32	40	50	63
B1 [mm (in)]	80 (3.15)	85 (3.35)	102 (4.02)	125 (4.92)	140 (5.51)	180 (7.09)
B2 [mm (in)]	65 (2.56)	85 (3.35)	102 (4.02)	125 (4.92)	140 (5.51)	180 (7.09)
H [mm (in)]	35 (1.38)	40 (1.57)	45 (1.77)	60 (2.36)	60 (2.36)	80 (3.15)
L1 [mm (in)]	-	-	61.3 (2.41)	80 (3.15)	80.4 (3.17)	74.9 (2.95)
L2 [mm (in)]	-	-	3.5 (0.14)	4.5 (0.18)	4.5 (0.18)	4.5 (0.18)
L3 [mm (in)]	1.5 (0.06)	1.5 (0.06)	1.5 (0.06)	1.5 (0.06)	1.5 (0.06)	1.5 (0.06)
L4 [mm (in)]	-	-	26 (1.02)	33.9 (1.33)	37.5 (1.48)	57 (2.24)
L5 [mm (in)]	-	-	15 (0.59)	20 (0.79)	21 (0.83)	26.25 (1.03)
L6 [mm (in)]	-	-	3.5 (0.14)	4.5 (0.18)	4.5 (0.18)	4.5 (0.18)
L7 [mm (in)]	7 (0.28)	23.5 (0.93)	32 (1.26)	43.5 (1.71)	51 (2.01)	63 (2.48)
L8 [mm (in)]	16.25 (0.64)	26.25 (1.03)	34.65 (1.36)	46.25 (1.82)	53.75 (2.12)	68.6 (2.7)
Nameplate position	C	C	F	C	A	A
ISO 7368 mounting pattern	BA-06-2-A	BB-08-2-A	BC-09-2-A	BD-10-2-A	BE-11-2-A	BF-12-2-A

1WDB COVER

Sizes 80 to 100

Cover Dimensions

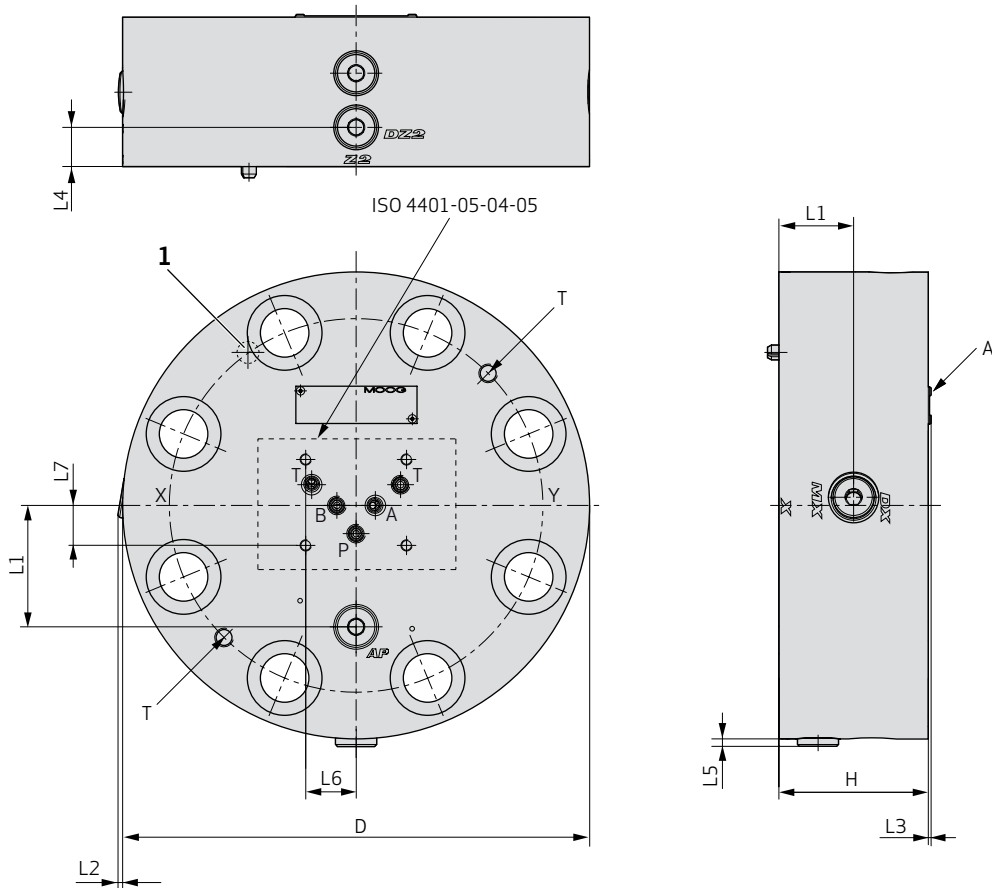

1 Locating pin

Size	80	100
D [mm (in)]	250 (9.84)	300 (11.81)
H [mm (in)]	80 (3.15)	90 (3.54)
L1 [mm (in)]	65 (2.56)	80 (3.15)
L2 [mm (in)]	2.5 (0.1)	2.5 (0.1)
L3 [mm (in)]	1.5 (0.06)	1.5 (0.06)
L4 [mm (in)]	21 (0.83)	25 (0.98)
L5 [mm (in)]	4 (0.16)	4 (0.16)
L6 [mm (in)]	27 (1.06)	27 (1.06)
L7 [mm (in)]	21.4 (0.84)	21.4 (0.84)
Nameplate position	A	A
ISO 7368 mounting pattern	BG-13-2-A	BH-14-2-A
T - (eye-bolt thread)	M10	M10

2D COVER

Functional Description

The 2D cover contains an integrated shuttle valve designed to allow only the highest of the available pilot pressures to continue to the C port. Depending on how the pilot ports are connected, the 2D can be used in combination with a cartridge¹⁾ to create both check and directional functions.

Directional Function

If the X and Y ports of the cover are connected to tank, then flow is enabled in both directions from A → B and B → A. If one or both of the X and Y ports are pressurised, then the highest of both pressures is acting to close the cartridge.

Check Function

If the X or Y port is connected to the A port of the cartridge, a check function is created, blocking the flow from A → B. Likewise, if the X or Y port is connected to the B port, flow will be blocked in the opposite direction, from B → A.

1) Cartridge with a B, C, E or F poppet.

Directional Function

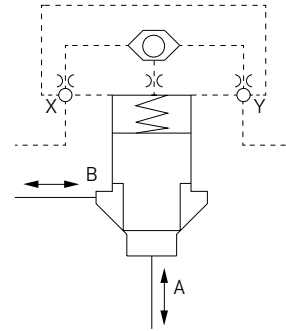

Check Function

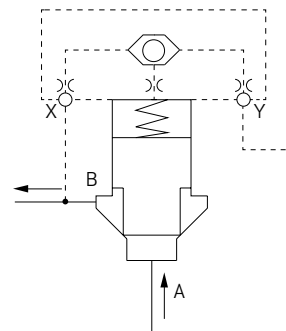

Hydraulic Symbol

Sizes 16 to 32 and 50

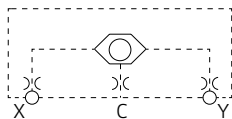

Size 40

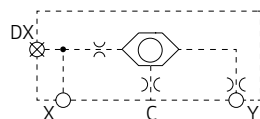

Sizes 63 to 100

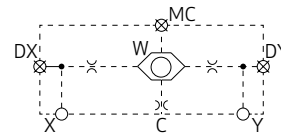

2D COVER

Orifice Configuration

The 2D cover can be equipped with orifices in the X, Y and C ports. Depending on the application, and how the X and Y ports are connected, these orifices can be used to limit the flow to and from the C port of the cover and thereby limit the opening and closing rate of the cartridge.

For assistance with orifice configuration please contact Moog.

Preferred Type (NBR)

Size	Ordering code without orifice	Ordering code with standard orifice	Orifice code ¹⁾
16	XEB18535-000N01	XEB18535-001N01	X08, Y08
25	XEB18517-000N01	XEB18517-001N01	X10, Y10
32	XEB18499-000N01	XEB18499-001N01	X12, Y12
40	XEB18441-000N01	XEB18441-001N01	X12, Y12
50	XEB18423-000N01	XEB18423-001N01	X15, Y15
63	XEB18331-000N01	XEB18331-001N01	X20, Y20
80	XEB18308-000N01	XEB18308-001N01	X25, Y25
100	XEB18293-000N01	XEB18293-001N01	X25, Y25

1) See ordering code (position 12) on page 63.

Cover Details

Size	16	25	32	40	50	63	80	100
Orifice details	See page 55							
Spare parts	See page 58							
Mounting screws	See table for mounting screws on page 58							
Plug DX, DY + MC	-	-	-	G1/8"	-	G1/4"	G3/8"	G1/2"
Hex key size [mm]	-	-	-	5	-	6	8	10
Torque [Nm (lbf ft)]	-	-	-	12 (9)	-	27 (20)	56 (41)	72 (53)
Plug W	G3/8"	G3/8"	G3/8"	G3/8"	G3/8"	G3/4"	G3/4"	G3/4"
Hex key size [mm]	8	8	8	8	8	12	12	12
Torque [Nm (lbf ft)]	56 (41)	56 (41)	56 (41)	56 (41)	56 (41)	120 (89)	120 (89)	120 (89)
Shuttle valve (under plug W)	-	-	-	-	-	G1/2"	G1/2"	G1/2"
Hex key size [mm]	-	-	-	-	-	10	10	10
Torque [Nm (lbf ft)]	-	-	-	-	-	40 (30)	40 (30)	40 (30)
Weight [kg (lb)]	1.1 (2.43)	1.7 (3.75)	3.1 (6.84)	6.3 (13.89)	8.2 (18.08)	17 (37.49)	26 (57.33)	42 (92.61)

2D COVER

Sizes 16 to 63

Cover Dimensions

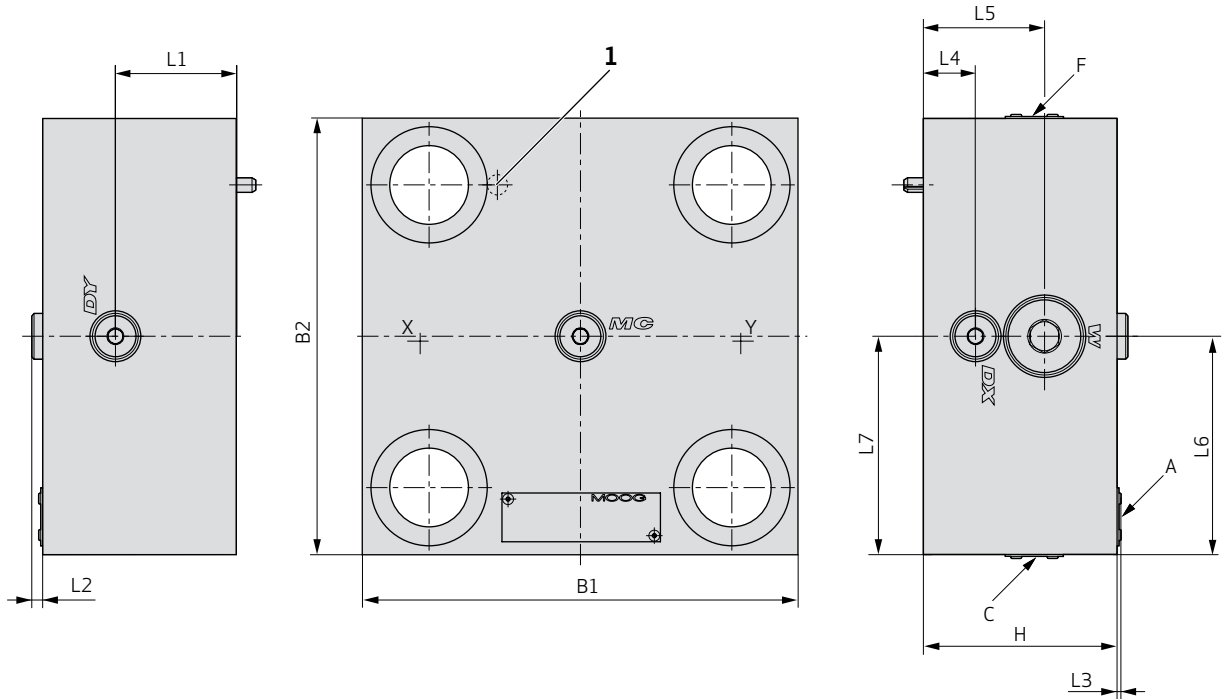

1 Locating pin

Size	16	25	32	40	50	63
B1 [mm (in)]	65 (2.56)	85 (3.35)	102 (4.02)	125 (4.92)	140 (5.51)	180 (7.09)
B2 [mm (in)]	65 (2.56)	85 (3.35)	102 (4.02)	125 (4.92)	140 (5.51)	180 (7.09)
H [mm (in)]	35 (1.38)	35 (1.38)	45 (1.77)	60 (2.36)	60 (2.36)	80 (3.15)
L1 [mm (in)]	-	-	-	-	-	50 (1.97)
L2 [mm (in)]	-	-	-	-	-	4.5 (0.18)
L3 [mm (in)]	1.5 (0.06)	1.5 (0.06)	1.5 (0.06)	1.5 (0.06)	1.5 (0.06)	1.5 (0.06)
L4 [mm (in)]	-	-	-	12.5 (0.49)	-	21.5 (0.85)
L5 [mm (in)]	21.5 (0.85)	21.5 (0.85)	30 (1.18)	33.5 (1.32)	45 (1.77)	50 (1.97)
L6 [mm (in)]	32.5 (1.28)	42.5 (1.67)	51 (2.01)	62.5 (2.46)	80 (3.15)	90 (3.54)
L7 [mm (in)]	-	-	-	62.5 (2.46)	-	90 (3.54)
Nameplate position	A	C	F	C	A	A
ISO 7368 mounting pattern	BA-06-2-A	BB-08-2-A	BC-09-2-A	BD-10-2-A	BE-11-2-A	BF-12-2-A

2D COVER

Sizes 80 to 100

Cover Dimensions

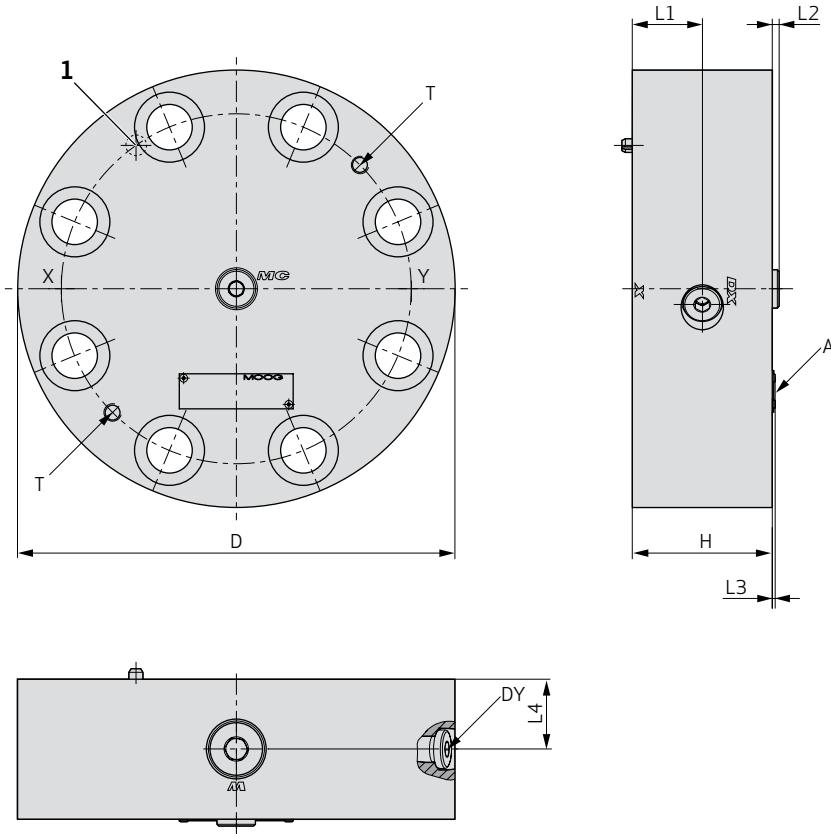

1 Locating pin

Size	80	100
D [mm (in)]	250 (9.84)	300 (11.81)
H [mm (in)]	80 (3.15)	90 (3.54)
L1 [mm (in)]	40 (1.57)	45 (1.77)
L2 [mm (in)]	4 (0.16)	4 (0.16)
L3 [mm (in)]	1.5 (0.06)	1.5 (0.06)
L4 [mm (in)]	40 (1.57)	45 (1.77)
Nameplate position	A	A
ISO 7368 mounting pattern	BG-13-2-A	BH-14-2-A
T - (eye-bolt thread)	M10	M10

2W COVER

Functional Description

The 2W cover contains an integrated shuttle valve designed to allow only the highest of the available pilot pressures to continue to the C port. In contrast to the 2D cover, the 2W cover is equipped with a port pattern. This additional port pattern enables more complex functions to be created by using a pilot valve.

Pilot-Operated Check Function

The 2W cover can be used in combination with a cartridge¹⁾ and a control valve²⁾ to create a check function that can be enabled depending upon the state of the solenoid.

When the solenoid is energized, the flow direction is A → B only. This is due to the plug in the B port of the 2W cover blocking the pilot pressure from the A port of the cartridge. The remaining pilot pressure connected to the B port of the cartridge blocks the flow direction B → A.

When the solenoid is de-energized the flow in both directions, from B → A and A → B, is blocked.

If the plug is installed in port A of the cover, the function is exactly the opposite with regard to an energized and de-energized solenoid. In other words, the flow in both directions will be blocked when the solenoid is energized. When the solenoid is de-energized, flow will only be permitted in the direction A → B.

Finally, the Z2 port may be used in combination with an additional control valve²⁾ to unlock the check function from B → A by connecting the spring chamber of the cartridge to tank. This will enable flow through the cartridge in both directions. Or, the Z2 port can also be used to activate a second cartridge valve.

- 1) Cartridge with a B, C, E or F poppet.
- 2) Control valve: A size O3 directional control valve for covers up to size 50 or a size O5 directional control valve for cover sizes 63 to 100.

Pilot-Operated Check Function

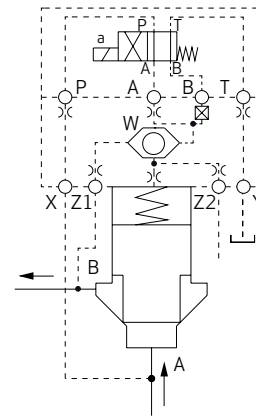

Hydraulic Symbol

Sizes 16 to 25

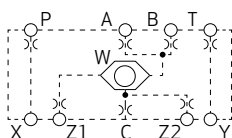

Sizes 32 to 50

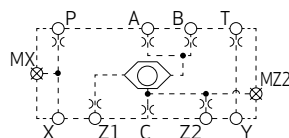

Sizes 63 to 100

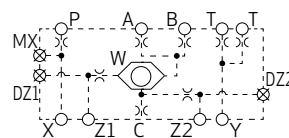

2W COVER

Orifice Configuration

The orifice configurations possible with this cover are numerous and depend on the pilot valve used and the function desired. For more assistance with orifice configurations please contact Moog.

Preferred Type (NBR)

Size	Ordering code without orifice	Ordering code with standard orifice	Orifice code ¹⁾
16	XEB18549-000N01	upon request	-
25	XEB18528-000N01	upon request	-
32	XEB18507-000N01	upon request	-
40	XEB18448-000N01	upon request	-
50	XEB18430-000N01	upon request	-
63	XEB18338-000N01	upon request	-
80	XEB18315-000N01	upon request	-
100	XEB18300-000N01	upon request	-

1) See ordering code (position 12) on page 63.

Cover Details

Size	16	25	32	40	50	63	80	100
Orifice details	See page 55							
Spare parts	See page 58							
Mounting screws	See table for mounting screws on page 58							
Plug MX, MZ2, DZ1 + DZ2	-	-	G1/8"	G1/4"	G1/4"	G1/4"	G3/8"	G1/2"
Hex key size [mm]	-	-	5	6	6	6	8	10
Torque [Nm (lbf ft)]	-	-	12 (9)	27 (20)	27 (20)	27 (20)	56 (41)	72 (53)
Plug W	G3/8"	G3/8"	G3/8"	G3/8"	G3/8"	G1/2"	G3/4"	G3/4"
Hex key size [mm]	8	8	8	8	8	10	12	12
Torque [Nm (lbf ft)]	56 (41)	56 (41)	56 (41)	56 (41)	56 (41)	72 (53)	120 (89)	120 (89)
Shuttle valve (under plug W)	-	-	-	-	-	G1/2"	G1/2"	G1/2"
Hex key size [mm]	-	-	-	-	-	10	10	10
Torque [Nm (lbf ft)]	-	-	-	-	-	40 (30)	40 (30)	40 (30)
Weight [kg (lb)]	1.5 (3.31)	2 (4.41)	3 (6.62)	6.2 (13.67)	8 (17.64)	16.5 (36.38)	26 (57.33)	44 (97.02)

2W COVER

Sizes 16 to 63

Cover Dimensions

Sizes 16 to 50

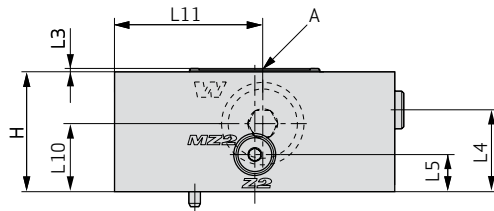

Size 63

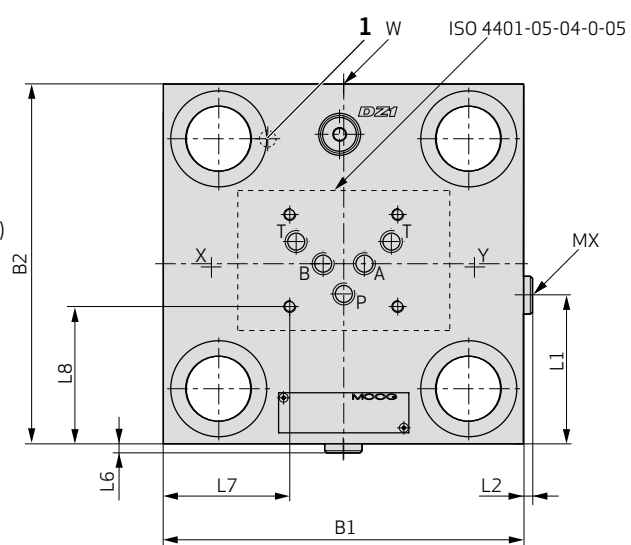
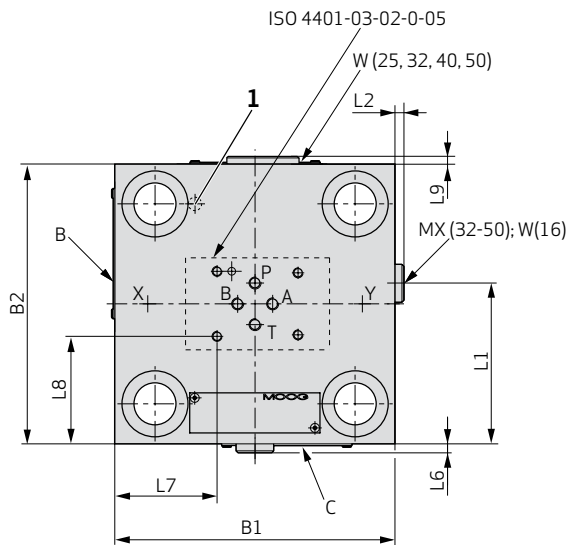
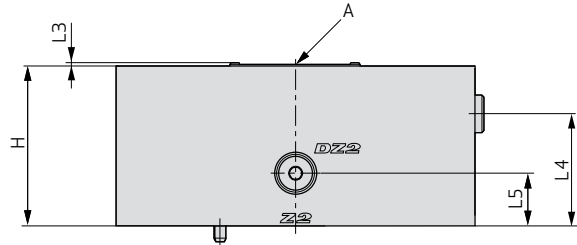

1 Locating pin

Size	16	25	32	40	50	63
B1 [mm (in)]	80 (3.15)	85 (3.35)	102 (4.02)	125 (4.92)	140 (5.51)	180 (7.09)
B2 [mm (in)]	65 (2.56)	85 (3.35)	102 (4.02)	125 (4.92)	140 (5.51)	180 (7.09)
H [mm (in)]	40 (1.57)	40 (1.57)	45 (1.77)	60 (2.36)	60 (2.36)	80 (3.15)
L1 [mm (in)]	35 (1.38)	-	58.9 (2.32)	73 (2.87)	80.4 (3.17)	74.5 (2.93)
L2 [mm (in)]	-	-	3.5 (0.14)	4.5 (0.18)	4.5 (0.18)	4.5 (0.18)
L3 [mm (in)]	1.5 (0.06)	1.5 (0.06)	1.5 (0.06)	1.5 (0.06)	1.5 (0.06)	1.5 (0.06)
L4 [mm (in)]	21 (0.83)	-	34 (1.34)	40.5 (1.59)	41 (1.61)	56 (2.2)
L5 [mm (in)]	-	-	21 (0.83)	17 (0.67)	18.5 (0.73)	26.25 (1.03)
L6 [mm (in)]	-	1 (0.04)	3.5 (0.14)	4.5 (0.18)	4.5 (0.18)	4.5 (0.18)
L7 [mm (in)]	7 (0.28)	23.5 (0.93)	32 (1.26)	43.5 (1.71)	51 (2.01)	63 (2.48)
L8 [mm (in)]	16.25 (0.64)	26.25 (1.03)	34.65 (1.36)	46.25 (1.82)	53.75 (2.12)	68.6 (2.7)
L9 [mm (in)]	1.6 (0.06)	2.5 (0.1)	-	-	-	-
L10 [mm (in)]	18 (0.71)	23 (0.91)	21 (0.83)	31 (1.22)	32 (1.26)	40 (1.57)
L11 [mm (in)]	46.2 (1.82)	45 (1.77)	51 (2.01)	62.5 (2.46)	70 (2.76)	79.7 (3.14)
Nameplate position	C	C	B	C	A	A
ISO 7368 mounting pattern	BA-06-2-A	BB-08-2-A	BC-09-2-A	BD-10-2-A	BE-11-2-A	BF-12-2-A

2W COVER

Sizes 80 to 100

Cover Dimensions

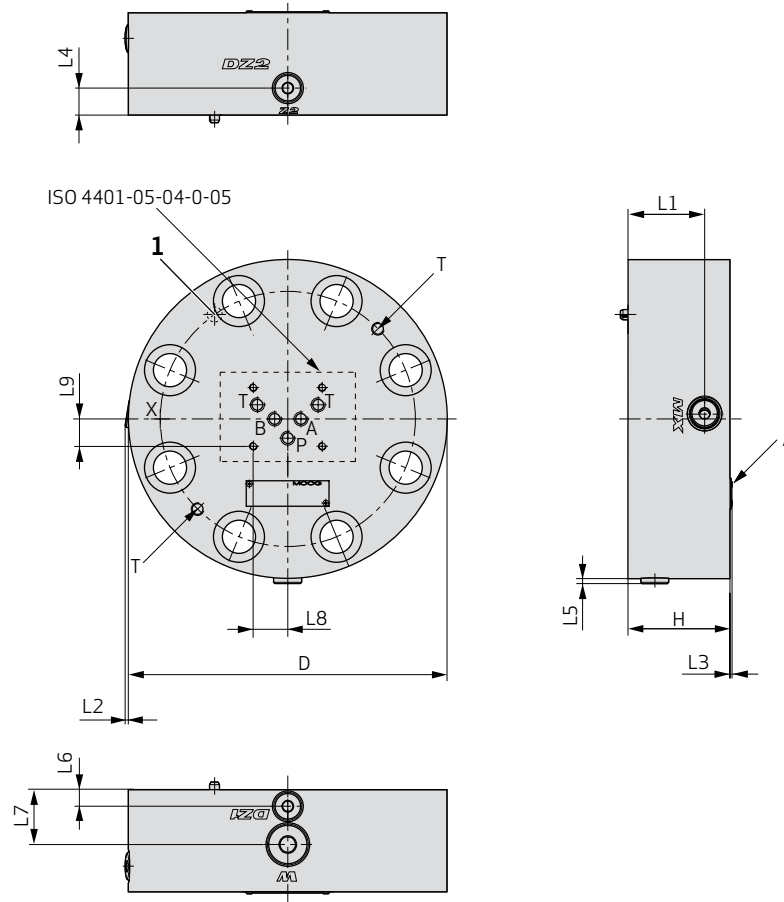

1 Locating pin

Size	80	100
D [mm (in)]	250 (9.84)	300 (11.81)
H [mm (in)]	80 (3.15)	90 (3.54)
L1 [mm (in)]	60 (2.36)	43 (1.69)
L2 [mm (in)]	2.5 (0.1)	2.5 (0.1)
L3 [mm (in)]	1.5 (0.06)	1.5 (0.06)
L4 [mm (in)]	21 (0.83)	23.9 (0.94)
L5 [mm (in)]	4 (0.16)	4 (0.16)
L6 [mm (in)]	15 (0.59)	24 (0.94)
L7 [mm (in)]	45 (1.77)	56.9 (2.24)
L8 [mm (in)]	27 (1.06)	27 (1.06)
L9 [mm (in)]	21.4 (0.84)	21.4 (0.84)
Nameplate position	A	A
ISO 7368 mounting pattern	BG-13-2-A	BH-14-2-A
T - (eye-bolt thread)	M10	M10

2WR COVER

Functional Description

The 2WR cover contains an integrated shuttle valve designed to allow only the highest of the available pilot pressures to continue to the C port. In contrast to the 2W cover, the 2WR cover uses only the X and the A ports to control the integrated shuttle valve. Ports B and Z2 can be used for other control functions.

Pilot-Operated Check Function

The 2WR can be used in combination with a cartridge¹⁾ and a control valve²⁾ to create a check function that can be enabled depending upon the state of the solenoid.

When the solenoid is energized, the flow direction is A → B only. This is due to the directional valve routing the pilot pressure from the A port of the cartridge away from the spring chamber and towards the Z2 port. If, however, the pressure in port B exceeds the one in port A, it closes the cartridge and blocks the flow direction B → A.

When the solenoid is de-energized the flow in both directions, from B → A and A → B, is blocked.

Finally, The Z2 port may be used to activate another cartridge¹⁾.

- 1) Cartridge with a B, C, E or F poppet.
- 2) Control valve: A size 03 directional control valve for covers up to size 50 or a size 05 directional control valve for cover sizes 63 to 100.

Pilot-Operated Check Function

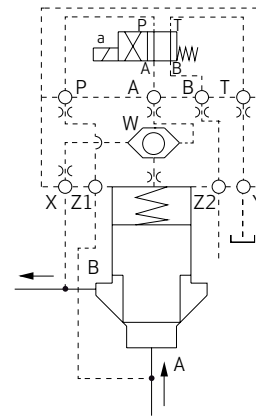

Hydraulic Symbol

Sizes 16 to 25

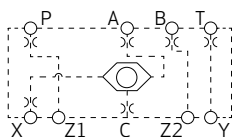

Sizes 32 to 50

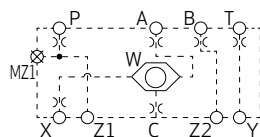

Sizes 63 to 100

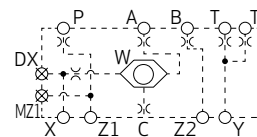

2WR COVER

Orifice Configuration

The orifice configurations possible with this cover are numerous and depend on the pilot valve used and the function desired. For more assistance with orifice configurations please contact Moog.

Preferred Type (NBR)

Size	Ordering code without orifice	Ordering code with standard orifice	Orifice code ¹⁾
16	XEB18548-000N01	upon request	-
25	XEB18525-000N01	upon request	-
32	XEB18501-000N01	upon request	-
40	XEB18442-000N01	upon request	-
50	XEB18424-000N01	upon request	-
63	XEB18332-000N01	upon request	-
80	XEB18309-000N01	upon request	-
100	XEB18294-000N01	upon request	-

1) See ordering code (position 12) on page 63.

Cover Details

Size	16	25	32	40	50	63	80	100
Orifice details	See page 55							
Spare parts	See page 58							
Mounting screws	See table for mounting screws on page 58							
Plug DX + MZ1	-	-	G1/8"	G1/4"	G1/4"	G1/4"	G3/8"	G1/2"
Hex key size [mm]	-	-	5	6	6	6	8	10
Torque [Nm (lbf ft)]	-	-	12 (9)	27 (20)	27 (20)	27 (20)	56 (41)	72 (53)
Plug W	G3/8"	G3/8"	G3/8"	G3/8"	G3/8"	G3/4"	G3/4"	G3/4"
Hex key size [mm]	8	8	8	8	8	12	12	12
Torque [Nm (lbf ft)]	56 (41)	56 (41)	56 (41)	56 (41)	56 (41)	120 (89)	120 (89)	120 (89)
Shuttle valve (under plug W)	-	-	-	-	-	G1/2"	G1/2"	G1/2"
Hex key size [mm]	-	-	-	-	-	10	10	10
Torque [Nm (lbf ft)]	-	-	-	-	-	40 (30)	40 (30)	40 (30)
Weight [kg (lb)]	1.5 (3.31)	2 (4.41)	3 (6.62)	6.2 (13.67)	9 (19.85)	23.6 (52.04)	26 (57.33)	42 (92.61)

2WR COVER

Sizes 16 to 63

Cover Dimensions

Sizes 16 to 50

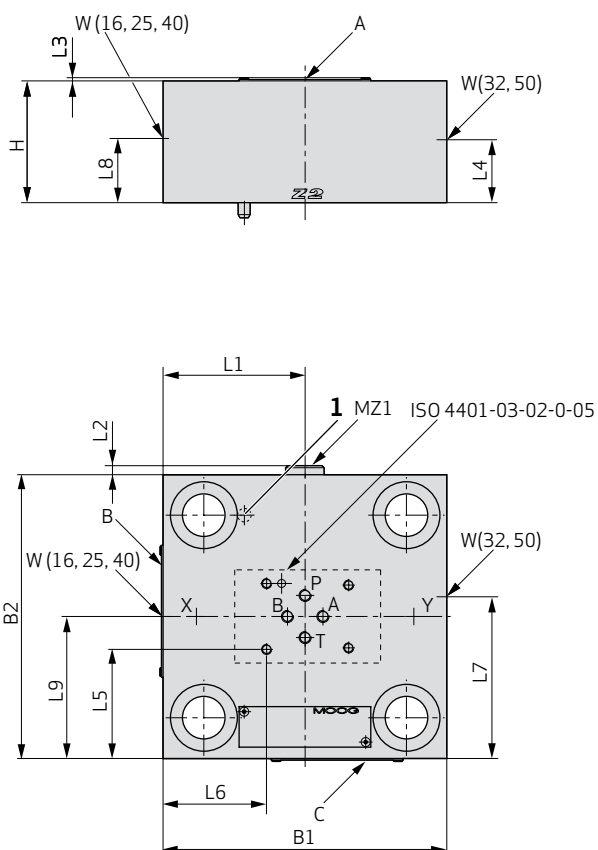

Size 63

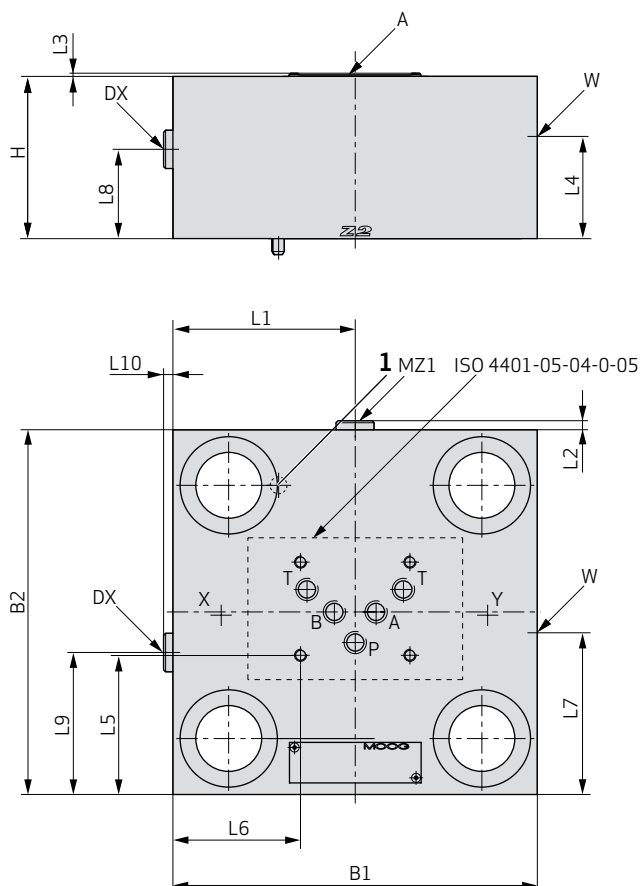

1 Locating pin

Size	16	25	32	40	50	63
B1 [mm (in)]	80 (3.15)	85 (3.35)	102 (4.02)	125 (4.92)	140 (5.51)	180 (7.09)
B2 [mm (in)]	65 (2.56)	85 (3.35)	102 (4.02)	125 (4.92)	140 (5.51)	180 (7.09)
H [mm (in)]	40 (1.57)	40 (1.57)	45 (1.77)	60 (2.36)	60 (2.36)	80 (3.15)
L1 [mm (in)]	-	-	51 (2.01)	62.5 (2.46)	70 (2.76)	90 (3.54)
L2 [mm (in)]	-	-	3.5 (0.14)	4.5 (0.18)	4.5 (0.18)	4.5 (0.18)
L3 [mm (in)]	1.5 (0.06)	1.5 (0.06)	1.5 (0.06)	1.5 (0.06)	1.5 (0.06)	1.5 (0.06)
L4 [mm (in)]	-	-	17.5 (0.69)	-	31 (1.22)	44 (1.73)
L5 [mm (in)]	16.25 (0.64)	26.25 (1.03)	34.65 (1.36)	46.25 (1.82)	73 (2.87)	68.6 (2.7)
L6 [mm (in)]	7 (0.28)	23.5 (0.93)	32 (1.26)	43.5 (1.71)	53.75 (2.12)	63 (2.48)
L7 [mm (in)]	-	-	63 (2.48)	-	51 (2.01)	70 (2.76)
L8 [mm (in)]	16.5 (0.65)	21 (0.83)	-	34.5 (1.36)	-	44 (1.73)
L9 [mm (in)]	31.5 (1.24)	43.5 (1.71)	-	64 (2.52)	-	70 (2.76)
L10 [mm (in)]	-	-	-	-	-	4.5 (0.18)
Nameplate position	C	C	B	C	A	A
ISO 7368 mounting pattern	BA-06-2-A	BB-08-2-A	BC-09-2-A	BD-10-2-A	BE-11-2-A	BF-12-2-A

2WR COVER

Sizes 80 to 100

Cover Dimensions

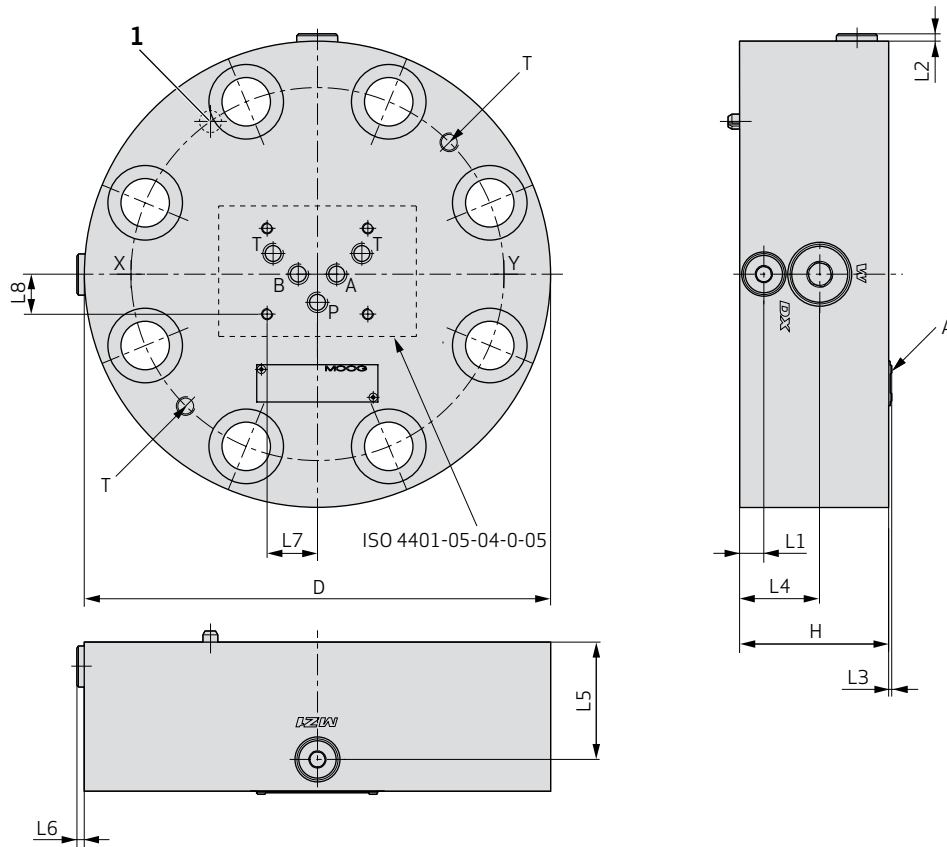

1 Locating pin

Size	80	100
D [mm (in)]	250 (9.84)	300 (11.81)
H [mm (in)]	80 (3.15)	90 (3.54)
L1 [mm (in)]	13 (0.51)	15.5 (0.61)
L2 [mm (in)]	4 (0.16)	4 (0.16)
L3 [mm (in)]	1.5 (0.06)	1.5 (0.06)
L4 [mm (in)]	43 (1.69)	48 (1.89)
L5 [mm (in)]	63 (2.48)	72 (2.83)
L6 [mm (in)]	4 (0.16)	4 (0.16)
L7 [mm (in)]	27 (1.06)	27 (1.06)
L8 [mm (in)]	21.4 (0.84)	21.4 (0.84)
Nameplate position	A	A
ISO 7368 mounting pattern	BG-13-2-A	BH-14-2-A
T - (eye-bolt thread)	M10	M10

4W COVER

Functional Description

The 4W cover offers parallel check functions on the X and Z1 ports. The larger pressure of the two is then applied to the P port. This feature is helpful in applications where the risk of a short-term opening of the cartridge¹⁾ during pilot pressure switching must be positively prevented.

Directional Function

When using a 4W cover in combination with a cartridge¹⁾ and a control valve²⁾, a bi-directional function or a check function can be achieved depending on the state of the solenoid.

When the solenoid is energized, and there is a plug in port B of the cover, then the spring chamber of the cartridge is connected to tank. This enables flow over the cartridge in both directions: From A → B and from B → A.

When the solenoid is de-energized the spring chamber is subject to the larger of the pilot pressures from the X and Z1 ports creating a check function. If this pilot pressure is drawn from the A side of the cartridge, then flow from A to B is blocked; and vice versa when the pilot pressure is drawn from B.

If the plug in the 4W cover is installed in port A instead of port B, then the functions with respect to an energized and a de-energized solenoid are reversed.

Finally, the Z2 port may be used to activate another cartridge¹⁾

- 1) Cartridge with a B, C, E or F poppet.
- 2) Control valve: A size 03 directional control valve for covers up to size 50 or a size 05 directional control valve for cover sizes 63 to 100.

Directional Function

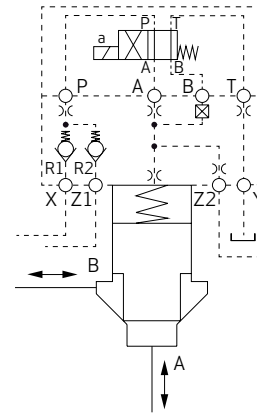

Hydraulic Symbol

Sizes 16 to 25

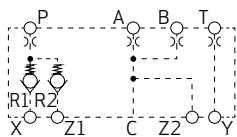

Sizes 32 to 50

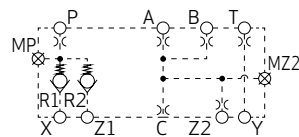

Sizes 63 to 100

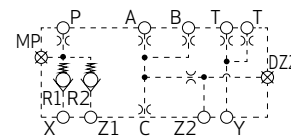

4W COVER

Orifice Configuration

The orifice configurations possible with this cover are numerous and depend on the pilot valve used and the function desired. For more assistance with orifice configurations please contact Moog.

Preferred Type (NBR)

Size	Ordering code without orifice	Ordering code with standard orifice	Orifice code ¹⁾
16	XEB18550-000N01	upon request	-
25	XEB18529-000N01	upon request	-
32	XEB18508-000N01	upon request	-
40	XEB18449-000N01	upon request	-
50	XEB18431-000N01	upon request	-
63	XEB18339-000N01	upon request	-
80	XEB18316-000N01	upon request	-
100	XEB18301-000N01	upon request	-

1) See ordering code (position 12) on page 63.

Cover Details

Size	16	25	32	40	50	63	80	100
Orifice details	See page 55							
Spare parts	See page 58							
Mounting screws	See table for mounting screws on page 58							
Plug MP, MZ2 + DZ2	-	-	G1/8"	G1/4"	G1/4"	G1/4"	G3/8"	G1/2"
Hex key size [mm]	-	-	5	6	6	6	8	10
Torque [Nm (lbf ft)]	-	-	12 (9)	27 (20)	27 (20)	27 (20)	56 (41)	72 (53)
Plug R1 + R2	G1/8"	G1/8"	G1/4"	G3/8"	G3/8"	G1/2"	G1"	G1"
Hex key size [mm]	5	5	6	8	8	10	17	17
Torque [Nm (lbf ft)]	12 (9)	12 (9)	27 (20)	56 (41)	56 (41)	80 (59)	170 (125)	170 (125)
Check valve (under plugs R1, R2)	RKVE04	RKVE04	RKVE06	RKVE08	RKVE08	REE10	REE15	REE15
Torque [Nm (lbf ft)] ¹⁾	3 (2)	3 (2)	7 (5)	15 (11)	15 (11)	-	-	-
Weight [kg (lb)]	1.5 (3.31)	2 (4.41)	3 (6.62)	6.2 (13.67)	9 (19.85)	16.5 (36.38)	26 (57.33)	44 (97.02)

1) Special tooling required for RKVE check valves, see RKVE Check Valve Tools on page 58

4W COVER

Sizes 16 to 63

Cover Dimensions

Sizes 16 to 50

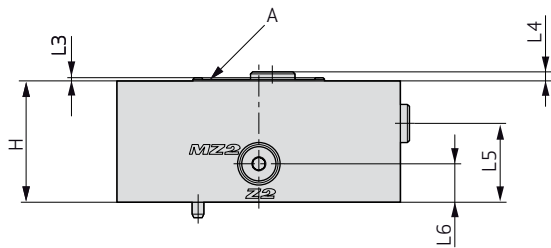

Size 63

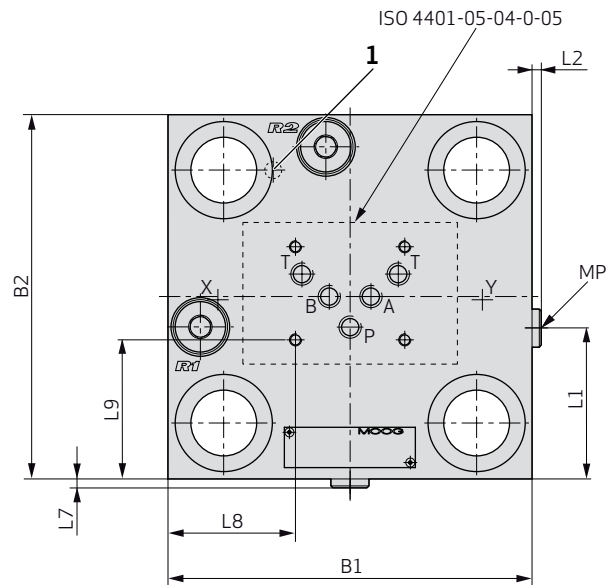
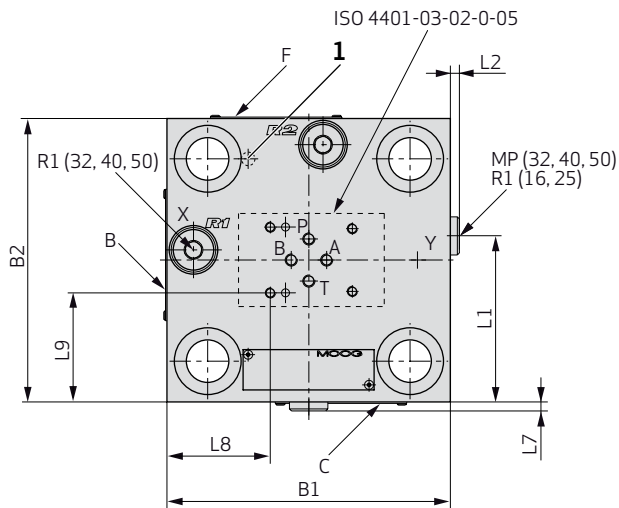
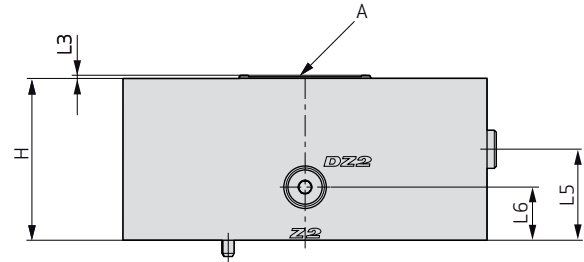

1 Locating pin

Size	16	25	32	40	50	63
B1 [mm (in)]	80 (3.15)	85 (3.35)	102 (4.02)	125 (4.92)	140 (5.51)	180 (7.09)
B2 [mm (in)]	65 (2.56)	85 (3.35)	102 (4.02)	125 (4.92)	140 (5.51)	180 (7.09)
H [mm (in)]	40 (1.57)	40 (1.57)	45 (1.77)	60 (2.36)	60 (2.36)	80 (3.15)
L1 [mm (in)]	43 (1.69)	53 (2.09)	59.5 (2.34)	73 (2.87)	82 (3.23)	74.5 (2.93)
L2 [mm (in)]	-	-	3.5 (0.14)	4.5 (0.18)	4.5 (0.18)	4.5 (0.18)
L3 [mm (in)]	1.5 (0.06)	1.5 (0.06)	1.5 (0.06)	1.5 (0.06)	1.5 (0.06)	1.5 (0.06)
L4 [mm (in)]	-	-	1 (0.04)	-	-	-
L5 [mm (in)]	17 (0.67)	20 (0.79)	24 (0.94)	38.5 (1.52)	39 (1.54)	45 (1.77)
L6 [mm (in)]	11.5 (0.45)	-	15 (0.59)	19 (0.75)	19 (0.75)	26.25 (1.03)
L7 [mm (in)]	1.4 (0.06)	-	3.5 (0.14)	4.5 (0.18)	4.5 (0.18)	4.5 (0.18)
L8 [mm (in)]	7 (0.28)	23.5 (0.93)	32 (1.26)	43.5 (1.71)	51 (2.01)	63 (2.48)
L9 [mm (in)]	16.25 (0.64)	26.25 (1.03)	34.65 (1.36)	46.25 (1.82)	53.75 (2.12)	68.6 (2.7)
Nameplate position	C	C	F	C	A	A
ISO 7368 mounting pattern	BA-06-2-A	BB-08-2-A	BC-09-2-A	BD-10-2-A	BE-11-2-A	BF-12-2-A

4W COVER

Sizes 80 to 100

Cover Dimensions

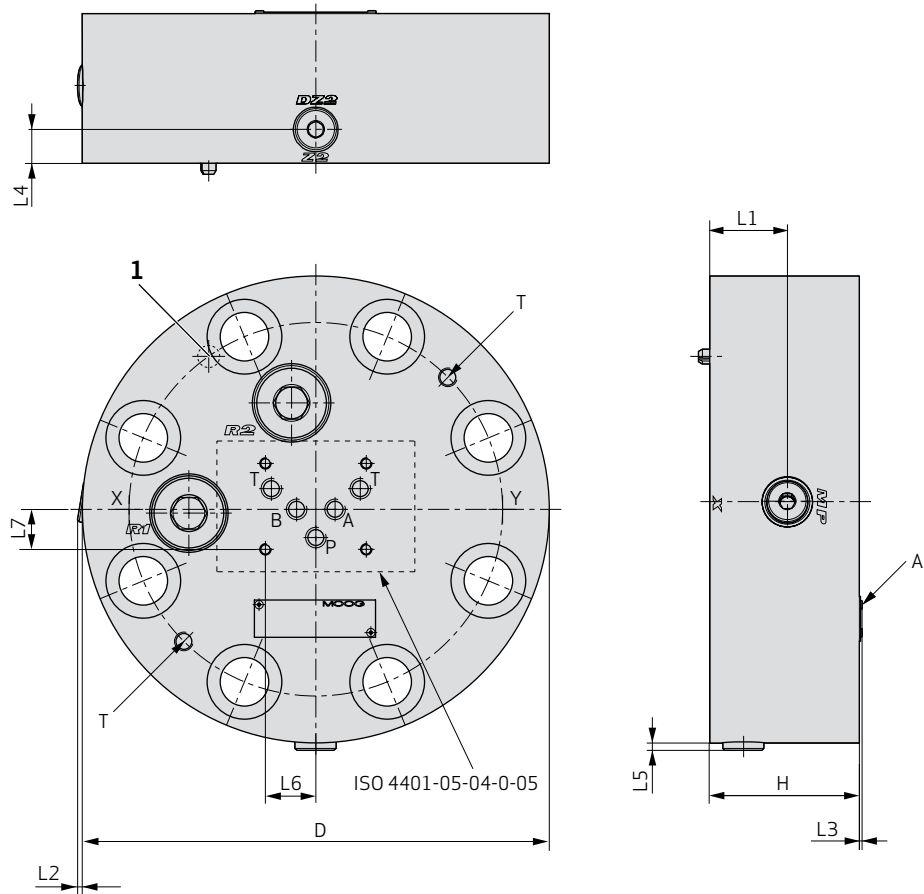

1 Locating pin

Size	80	100
D [mm (in)]	250 (9.84)	300 (11.81)
H [mm (in)]	80 (3.15)	90 (3.54)
L1 [mm (in)]	41.5 (1.63)	50 (1.97)
L2 [mm (in)]	2.5 (0.1)	2.8 (0.11)
L3 [mm (in)]	1.5 (0.06)	1.5 (0.06)
L4 [mm (in)]	18 (0.71)	25 (0.98)
L5 [mm (in)]	4 (0.16)	4 (0.16)
L6 [mm (in)]	27 (1.06)	27 (1.06)
L7 [mm (in)]	21.4 (0.84)	21.4 (0.84)
Nameplate position	A	A
ISO 7368 mounting pattern	BG-13-2-A	BH-14-2-A
T - (eye-bolt thread)	M10	M10

RV COVER

Functional Description

The RV cover contains an integrated shuttle valve with the possibility of an override.

Pilot-Operated Check Function

When using an RV cover in combination with a cartridge¹⁾, a check function is achieved by connecting the Z2 port with port B of the cartridge valve. The flow direction is A → B (B → A blocked).

An override of the check function is possible if the X port is subject to pressure. This will cause the shuttle valve to open towards the Y port and drain the spring chamber of the cartridge to tank. For the override to function, the pilot pressure at port X must be at least 20 % (1:5) of the load pressure in port B.

1) Cartridge with a B, C, E or F poppet

Pilot-Operated Check Function

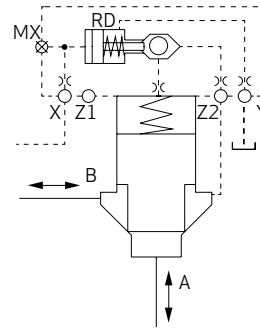

Hydraulic Symbol

Sizes 16 to 25

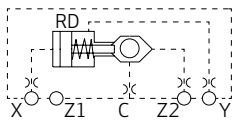

Sizes 32 to 50

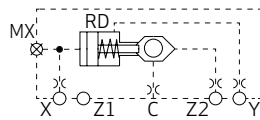

Sizes 63 to 100

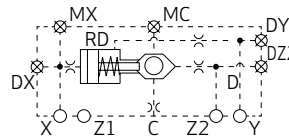

RV COVER

Orifice Configuration

For assistance with orifice configuration please contact Moog.

Preferred Type (NBR+PU)

RV Cover	Ordering code without orifice	Ordering code with standard orifice	Orifice code ¹⁾
16	XEB18919-000T01	XEB18919-010T01	X10, C15, Z215
25	XEB18918-000T01	XEB18918-008T01	X10, C15, Z215
32	XEB18510-000T01	XEB18510-014T01	X10, C15, Z215
40	XEB18451-000T01	XEB18451-004T01	X10, C15, Z215
50	XEB18433-000T01	XEB18433-002T01	X10, C15, Z215
63	XEB18341-000T01	upon request	-
80	XEB18318-000T01	upon request	-
100	XEB18303-000T01	upon request	-

1) See ordering code (position 12) on page 63.

Cover Details

Size	16	25	32	40	50	63	80	100
Orifice details	See page 55							
Spare parts	See page 58							
Mounting screws	See table for mounting screws on page 58							
Plug MX, MC, DX, DY + DZ2	-	G1/4"	G1/8"	G1/4"	G1/4"	G1/4"	G3/8"	G1/2"
Hex key size [mm]	-	6	5	6	6	6	8	10
Torque [Nm (lbf ft)]	-	27 (20)	12 (9)	27 (20)	27 (20)	27 (20)	56 (41)	72 (53)
Plug RD	G3/4"	G3/4"	G3/4"	G3/4"	G3/4"	G1"	G1"	G1"
Hex key size [mm]	12	12	12	12	12	17	17	17
Torque [Nm (lbf ft)]	120 (89)	120 (89)	120 (89)	120 (89)	120 (89)	170 (125)	170 (125)	170 (125)
Area ratio RD	1 : 5.4	1 : 5.4	1 : 5.4	1 : 5.4	1 : 5.4	1 : 5.4	1 : 5.4	1 : 5.4
Weight [kg (lb)]	2.3 (5.07)	2.8 (6.17)	3 (6.62)	6.1 (13.45)	8.9 (19.62)	16.4 (36.16)	26 (57.33)	41.4 (91.29)

RV COVER

Sizes 16 to 63

Cover Dimensions

Sizes 16 to 50

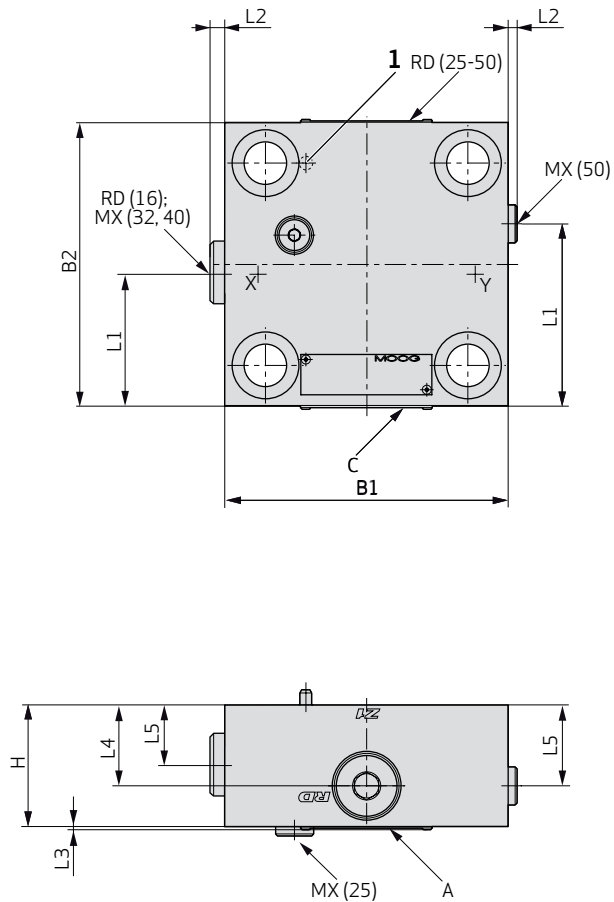

Size 63

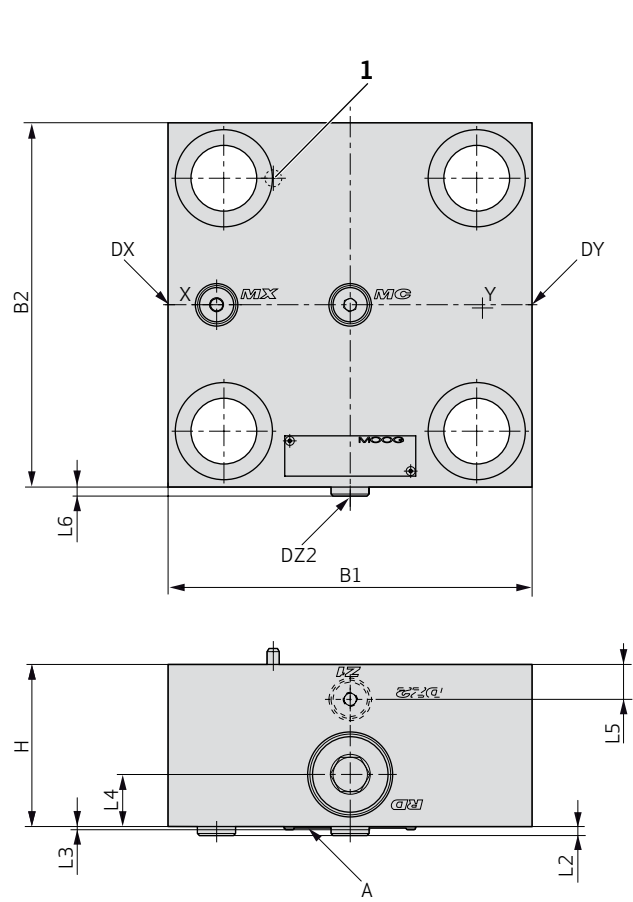

1 Locating pin

Size	16	25	32	40	50	63
B1 [mm (in)]	80 (3.15)	85 (3.35)	102 (4.02)	125 (4.92)	140 (5.51)	180 (7.09)
B2 [mm (in)]	65 (2.56)	85 (3.35)	102 (4.02)	125 (4.92)	140 (5.51)	180 (7.09)
H [mm (in)]	65 (2.56)	60 (2.36)	45 (1.77)	60 (2.36)	60 (2.36)	80 (3.15)
L1 [mm (in)]	32.5 (1.28)	-	48 (1.89)	59 (2.32)	90 (3.54)	-
L2 [mm (in)]	4.5 (0.18)	4.5 (0.18)	3.5 (0.14)	4.5 (0.18)	4.5 (0.18)	4.5 (0.18)
L3 [mm (in)]	1.5 (0.06)	1.5 (0.06)	1.5 (0.06)	1.5 (0.06)	1.5 (0.06)	1.5 (0.06)
L4 [mm (in)]	-	42 (1.65)	27 (1.06)	40 (1.57)	40 (1.57)	44 (1.73)
L5 [mm (in)]	45 (1.77)	-	19 (0.75)	40 (1.57)	40 (1.57)	-
L6 [mm (in)]	-	-	-	-	-	4.5 (0.18)
Nameplate position	C	C	C	C	A	A
ISO 7368 mounting pattern	BA-06-2-A	BB-08-2-A	BC-09-2-A	BD-10-2-A	BE-11-2-A	BF-12-2-A

RV COVER

Sizes 80 to 100

Cover Dimensions

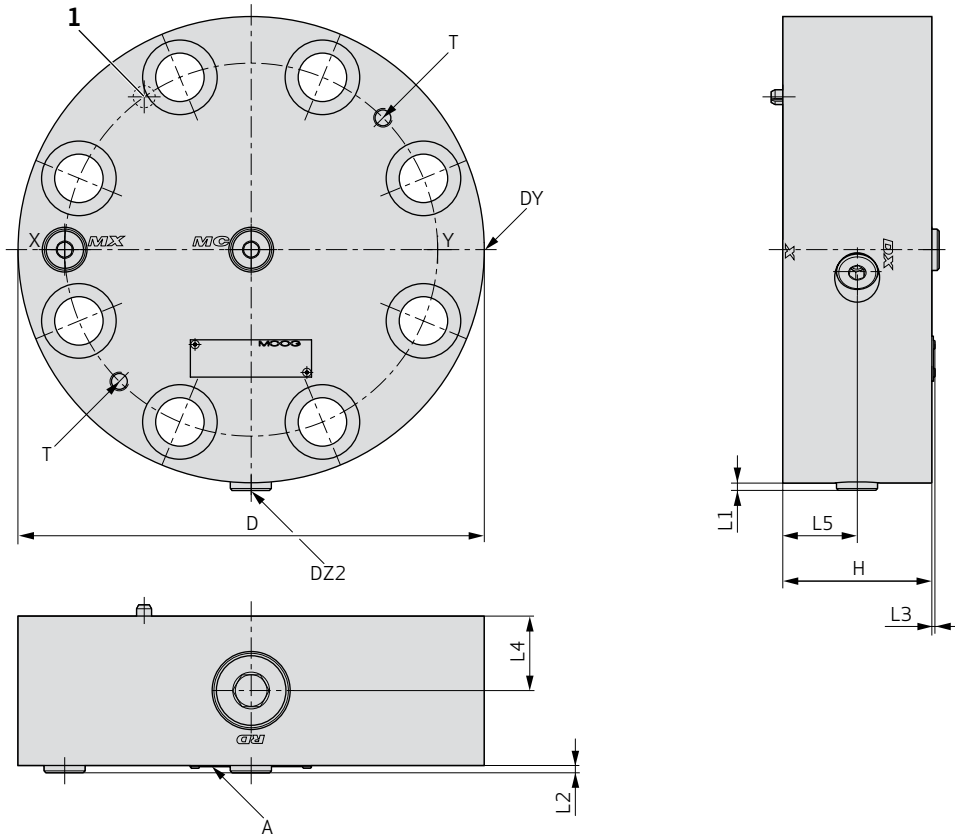

1 Locating pin

Size	80	100
D [mm (in)]	250 (9.84)	300 (11.81)
H [mm (in)]	80 (3.15)	90 (3.54)
L1 [mm (in)]	4 (0.16)	4 (0.16)
L2 [mm (in)]	4 (0.16)	4 (0.16)
L3 [mm (in)]	1.5 (0.06)	1.5 (0.06)
L4 [mm (in)]	40 (1.57)	45 (1.77)
L5 [mm (in)]	40 (1.57)	45 (1.77)
Nameplate position	A	A
ISO 7368 mounting pattern	BG-13-2-A	BH-14-2-A
T - (eye-bolt thread)	M10	M10

SELECTION OF ORIFICE SIZE

This calculation is used to select the orifice size which influences the opening and closing times. It may be necessary to optimize the settings on the machine. Using the diagram below, the cartridge opening and closing times may be calculated for various orifice sizes.

The pilot oil volume can be read from the applicable cartridge catalog.

Equation:

$$\text{Opening and closing time [ms]} = \frac{\text{Pilot oil volume cartridge [cm}^3\text{]} \times 60}{\text{Orifice flow (diagram) [l/min]}}$$

Example:

For Δp of 90 bar (1,300 psi) through a 0.8 mm orifice in size 25 cartridge with B cone, the cone takes approximately 184 ms for the complete stroke.

$$\text{Opening and closing time [ms]} = \frac{9.2 \text{ [cm}^3\text{]} \times 60}{3 \text{ [l/min]}} = 184 \text{ ms}$$

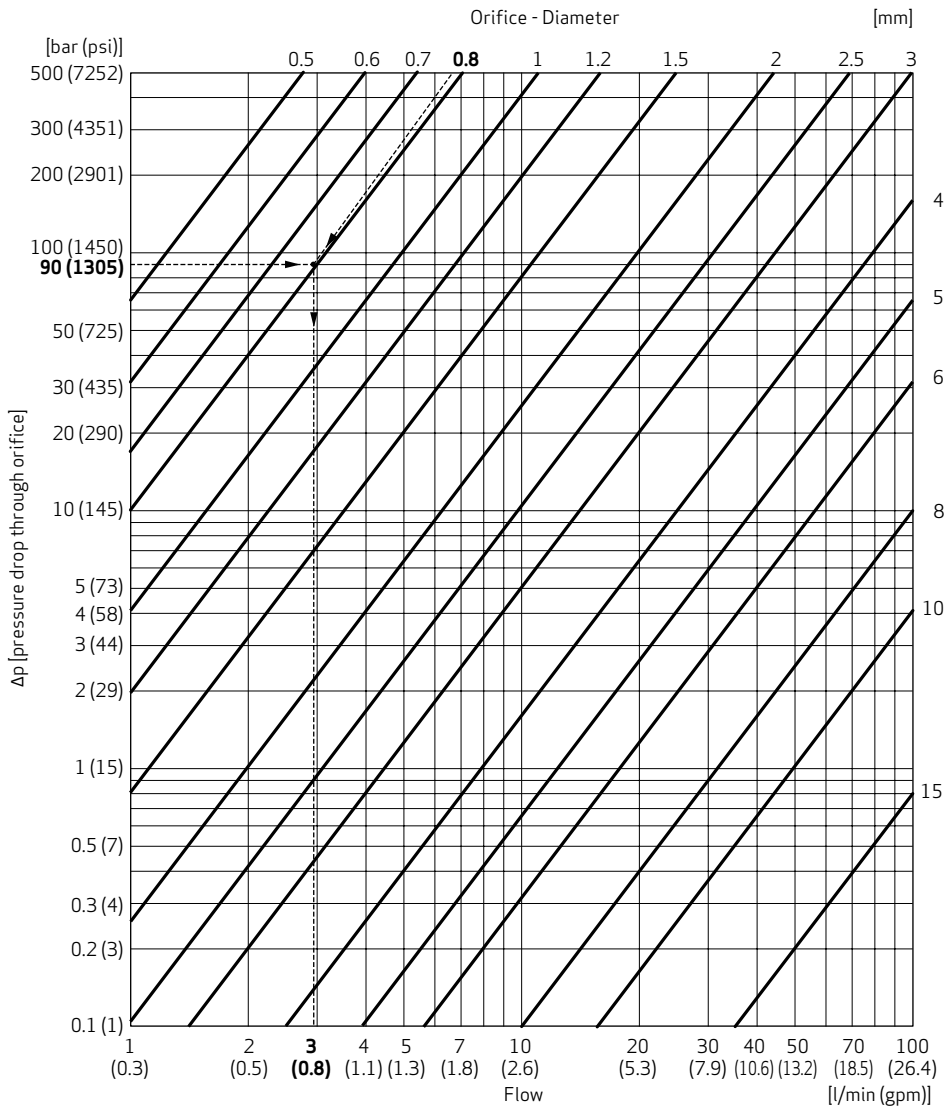

ORIFICE OPTIONS

Orifice Installation Options in the Cover

Typ	Orifices in ports										Orifices can be replaced from the outside	
	P	A	B	T	X	Y	Z1	Z2	C	AP		
1D					X							All nominal sizes
1H					X							From Sizes 25 to 100
RM	X	X	X	X								-
DRE	X	X	X	X				X	X			From Sizes 63 to 100 → Z2
1W	X	X	X	X				X	X			From Sizes 63 to 100 → Z2
1WDB	X	X	X	X	X			X	X	X		From Sizes 16 to 50 → AP From Sizes 63 to 100 → X, Z2, AP
2D					X	X			X			From Sizes 63 to 100 → X, Y
2W	X	X	X	X			X	X	X			From Sizes 63 to 100 → Z1, Z2
2WR	X	X	X	X	X				X			From Sizes 63 to 100 → X
4W	X	X	X	X				X	X			From Sizes 63 to 100 → Z2
RV					X	X		X	X			From Sizes 63 to 100 → X, Y, Z2

Note: Orifice installation options in the cover are identified on the cover, e.g., "DX, DY, DZ1, DZ2"

DX means that an orifice can be installed in port X.

Identifiers starting with "M..." mark the test port for the port concerned.

Orifice Thread Sizes

Port	16	25	32	40	50	63	80	100
P, A, B, T	M6	M6	M6	M6	M6	M10	M10	M10
X, C, Z1, Z2, Y	M5	M6	M6	M8	M8	M10	M14	M16
AP	M5	M6	M6	M8	M8	M10	M14	M16

INSTALLATION DIMENSIONS

In Accordance with ISO 7386:1989-08

Cartridge Cavity

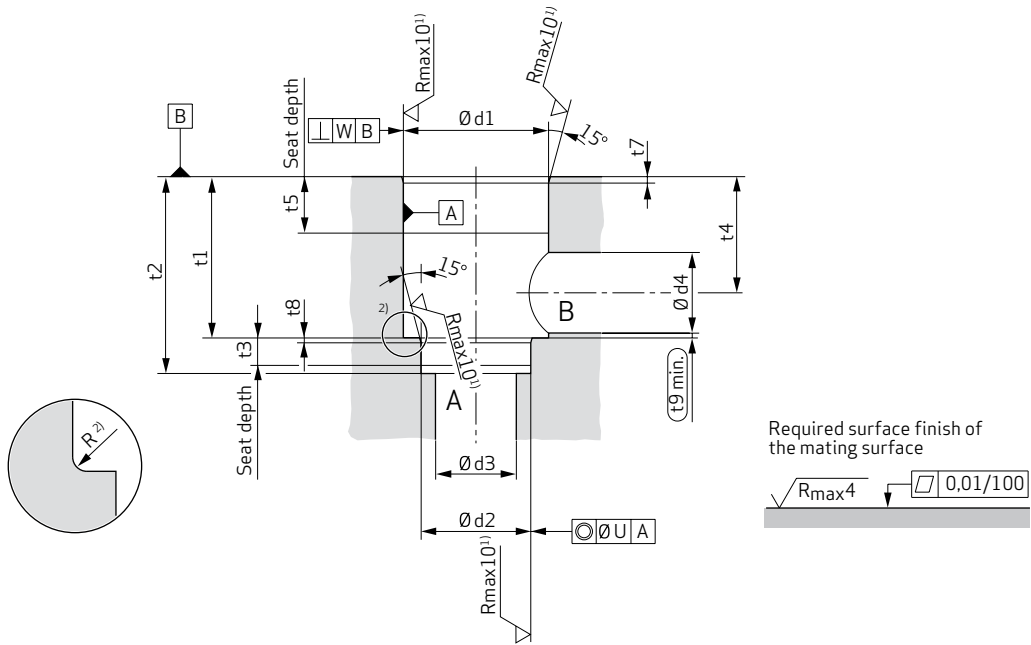

Bolt and Port Pattern

Sizes 16 to 63

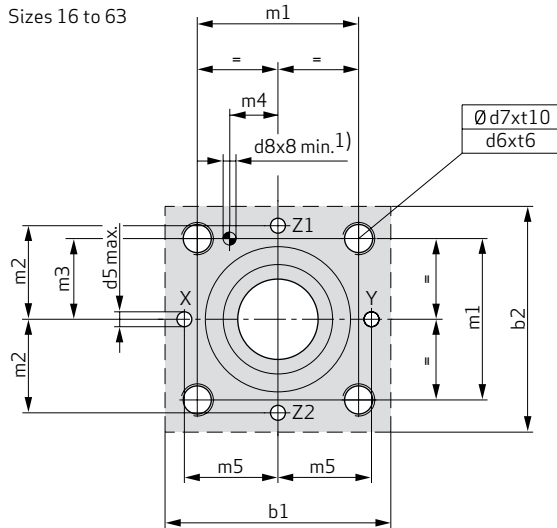

Sizes 80 to 100

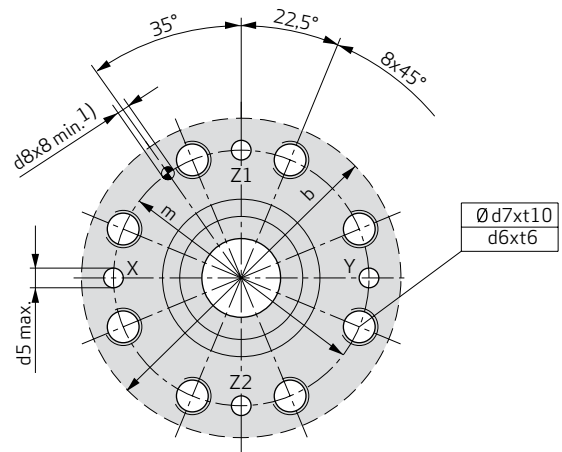

- 1) Recommendation deviates from the standard
- 2) For operating pressure greater than 350 bar (5,000 psi) Moog recommends a flanging radius of R 1.2 mm for Sizes 16 to 32 and R 4 mm for Sizes 40 to 100 deviating from ISO 7368

INSTALLATION DIMENSIONS

In Accordance with ISO 7386:1989-08

Size	16	25	32	40	50	63
b1	65 (2.56)	85 (3.35)	102 (4.02)	125 (4.92)	140 (5.51)	200 (7.87)
b2	65 (2.56)	85 (3.35)	102 (4.02)	125 (4.92)	140 (5.51)	180 (7.09)
d1^{H7 1)}	32 (1.26)	45 (1.77)	60 (2.36)	75 (2.95)	90 (3.54)	120 (4.72)
d2^{H7 1)}	25 (0.98)	34 (1.34)	45 (1.77)	55 (2.17)	68 (2.68)	90 (3.54)
d3	16 (0.63)	25 (0.98)	32 (1.26)	40 (1.57)	50 (1.97)	63 (2.48)
d4	16 (0.63)	25 (0.98)	32 (1.26)	40 (1.57)	50 (1.97)	63 (2.48)
d4_{max.}¹⁾	25 (0.98)	32 (1.26)	40 (1.57)	50 (1.97)	63 (2.48)	80 (3.15)
d5_{max.}	4 (0.16)	6 (0.24)	8 (0.31)	10 (0.39)	10 (0.39)	12 (0.47)
d6	M8	M12	M16	M20	M20	M30
d7	6.8 (0.27)	10.2 (0.4)	14 (0.55)	17.5 (0.69)	17.5 (0.69)	26.5 (1.04)
d8^{H13}	4 (0.16)	6 (0.24)	6 (0.24)	6 (0.24)	8 (0.31)	8 (0.31)
m1^{±0.2}	46 (1.81)	58 (2.28)	70 (2.76)	85 (3.35)	100 (3.94)	125 (4.92)
m2^{±0.2}	25 (0.98)	33 (1.3)	41 (1.61)	50 (1.97)	58 (2.28)	75 (2.95)
m3^{±0.2}	23 (0.91)	29 (1.14)	35 (1.38)	42.5 (1.67)	50 (1.97)	62.5 (2.46)
m4^{±0.2}	10.5 (0.41)	16 (0.63)	17 (0.67)	23 (0.91)	30 (1.18)	38 (1.5)
m5^{±0.2}	25 (0.98)	33 (1.3)	41 (1.61)	50 (1.97)	58 (2.28)	75 (2.95)
t1^{+0.1}	43 (1.69)	58 (2.28)	70 (2.76)	87 (3.43)	100 (3.94)	130 (5.12)
t2^{+0.1}	56 (2.2)	72 (2.83)	85 (3.35)	105 (4.13)	122 (4.8)	155 (6.1)
t3	11 (0.43)	12 (0.47)	13 (0.51)	15 (0.59)	17 (0.67)	20 (0.79)
t4	34 (1.34)	44 (1.73)	52 (2.05)	64 (2.52)	72 (2.83)	95 (3.74)
t4 for d4_{max.}¹⁾	29.5 (1.16)	40.5 (1.59)	48 (1.89)	59 (2.32)	65.5 (2.58)	86.5 (3.41)
t5	20 (0.79)	30 (1.18)	30 (1.18)	30 (1.18)	35 (1.38)	40 (1.57)
t6	14 (0.55)	20 (0.79)	26 (1.02)	33 (1.3)	33 (1.3)	50 (1.97)
t7	2 (0.08)	2.5 (0.1)	2.5 (0.1)	3 (0.12)	4 (0.16)	4 (0.16)
t8	2 (0.08)	2.5 (0.1)	2.5 (0.1)	3 (0.12)	3 (0.12)	4 (0.16)
t9	0.5 (0.02)	1.0 (0.04)	1.5 (0.06)	2.5 (0.1)	2.5 (0.1)	3 (0.12)
t10	17 (0.67)	24 (0.94)	31 (1.22)	38 (1.5)	38 (1.5)	56 (2.2)
U	0.03 (0)	0.03 (0)	0.03 (0)	0.05 (0)	0.05 (0)	0.05 (0)
W	0.05 (0)	0.05 (0)	0.1 (0)	0.1 (0)	0.1 (0)	0.2 (0.01)

Size	80	100
b_{max.}	250 (9.84)	300 (11.81)
d1^{H7 1)}	145 (5.71)	180 (7.09)
d2^{H7 1)}	110 (4.33)	135 (5.31)
d3	80 (3.15)	100 (3.94)
d4	80 (3.15)	100 (3.94)
d4_{max.}¹⁾	100 (3.94)	125 (4.92)
d5_{max.}	16 (0.63)	20 (0.79)
d6	M24	M30
d7	21 (0.83)	26.5 (1.04)
d8^{H13}	10 (0.39)	10 (0.39)
m^{±0.3}	200 (7.87)	245 (9.65)
t1	175 (6.89)	210 (8.27)
t2^{±0.2}	205 (8.07)	245 (9.65)
t3	25 (0.98)	29 (1.14)
t4	130 (5.12)	155 (6.1)
t4 for d4_{max.}¹⁾	120 (4.72)	142.5 (5.61)
t5	40 (1.57)	50 (1.97)
t6	39 (1.54)	50 (1.97)
t7	5 (0.2)	5 (0.2)
t8	5 (0.2)	5 (0.2)
t9	3 (0.12)	5 (0.2)
t10	45 (1.77)	56 (2.2)
U	0.05 (0)	0.05 (0)
W	0.2 (0.01)	0.2 (0.01)

1) Recommendation deviates from the standard

Note: Dimensions in mm (in)

ACCESSORIES AND SPARE PARTS

Seal Kits

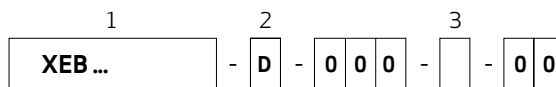

1 Base part number:	XEB ...
The base part number of the seal kit is identical to the base part number of the cover.	

3 Seal material	
N	NBR (standard)
T	NBR + PU
V	FKM
M	FKM + PU
2 Indicator	
D	Seal kit

Example: Part number seal kit cover type "1D" Size 25

Naming	Part number
N-SEAL KIT CCE25K61D	XEB18516D000N00
N-CCE25K61D0X99/X25	XEB18516-013N01
	Base part number

Mounting Screws

Size	Screw	Hex key [mm]	Quantity	Torque [Nm (lbf ft)]	Order number
16	M8x35	6	4	30 (22)	X784-10818
25	M12x40	10		100 (74)	X784-11202
32	M16x50	14		300 (221)	X784-11601
40, 50	M20x70	17		550 (406)	X784-12002
63	M30x90	22		1,800 (1,328)	X784-13008
80	M24x90	19	8	900 (664)	X784-12401
100	M30x100	22		1,800 (1,328)	X784-13009

RKVE Check Valve Tools

Size	Check valve	Type	Thread	Torque [Nm (lbf ft)]	Order number
16, 25	RKVE04		G1/8"	3 (2)	X998-00310
32	RKVE06		G1/4"	7 (5)	X998-00313
40, 50	RKVE08		G3/8"	15 (11)	X998-00311

Spare Parts 1H Cover

Size	16	25	32	40
Spindle (with poppet insert, NBR)	XEB19316-016N00	XEB19316-025N00	XEB19316-032N00	XEB19316-040N00
Poppet insert only	-	-	CB89121-032	CB89121-040
Tamper proof cap set	XEB19317-016-00	XEB19317-025-00	XEB19317-032-00	XEB19317-040-00

Size	50	63	80	100
Spindle (with poppet insert, NBR)	XEB19316-050N00	XEB19316-063-00	XEB19316-080-00	XEB19316-100-00
Poppet insert only	CB89121-050	CB89121-063	CB89121-080	CB89121-100
Tamper proof cap set	XEB19317-050-00	XEB19317-063-00	-	-

ABOUT MOOG

Moog Inc. is a worldwide designer, manufacturer and integrator of precision control components and systems. Moog's Industrial Group designs and manufactures high performance motion control solutions combining electric, hydraulic, and hybrid technologies with expert consultative support in a range of applications including energy production and generation machinery, industrial production machinery and simulation and test equipment. We help performance-driven companies design and develop their next-generation machines. Moog Industrial Group, with fiscal year 2013 sales of USD 592 million and over 40 locations worldwide, is part of Moog Inc. (NYSE:MOG.A and MOG.B) which has sales of USD 2.61 billion.

This vast scope ensures that our engineers remain close to the needs of machine builders and provide flexible design solutions and technical expertise tailored to our customers' toughest challenges.

Moog experts work in close collaboration with machine builders and application engineers to design motion control systems for greater productivity, higher reliability, superior connectivity, less costly maintenance and more effective operations. Our regional presence, industry knowledge and design flexibility ensures Moog motion control solutions are tailored to their environment — from meeting operating regulations and performance standards, to taking machine performance to a higher level.

Products

At the heart of every Moog solution is an array of products engineered for precision, high performance and reliability. For more than six decades, Moog products have been specified for critical machine applications.

Some are developed specifically for unique operating environments. Others are standard equipment on machines across many industries. All are continuously improved to take advantage of the latest technology breakthroughs and advancements.

Moog products include:

- Servo Valves and Proportional Valves
- Servo Motors and Servo Drives
- Servo Controllers and Software
- Radial Piston Pumps
- Actuators
- Integrated Hydraulic Manifold Systems and Cartridge Valves
- Slip Rings
- Motion Bases

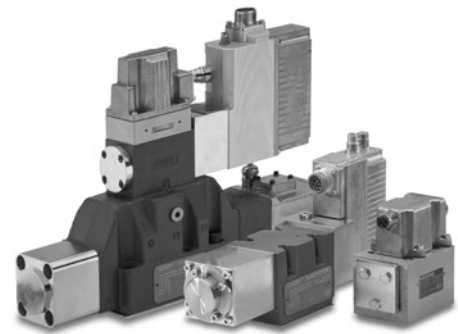

Servo Valves

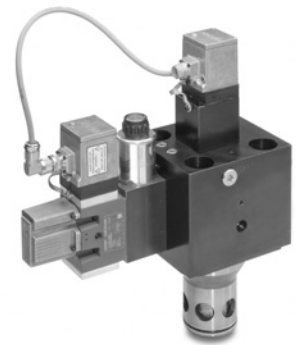

Servo Cartridge Valves

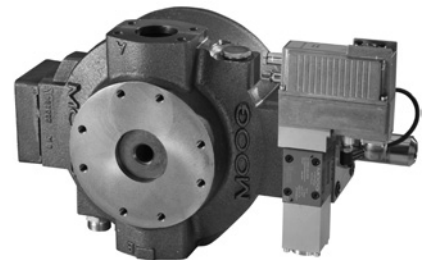

Radial Piston Pumps



Servo Drives

ABOUT MOOG

Solutions

Hydraulic Solutions

Since Bill Moog invented the first commercially viable servo valve in 1951, Moog has set the standard for world-class hydraulic technology. Today, Moog products are used in a variety of applications - providing high power, enhanced productivity and ever better performance for some of the worlds most demanding applications.

Electric Solutions

Clean operation, low noise generation, less maintenance and reduced power consumption make Moog electric solutions ideal for applications worldwide. Moog is the ideal partner for applications where transitioning technologies requires special expertise.

Hybrid Solutions

By incorporating the advantages of existing hydraulic and electric technologies - including modular flexibility, increased efficiency and cleanliness - into innovative hybrid solutions, Moog offers new performance potential in specialized applications.

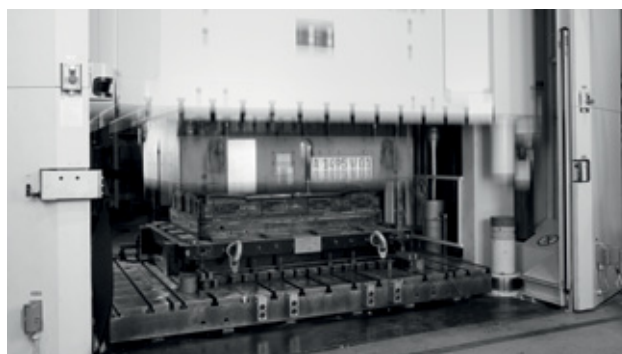

Press



Injection Molding Machine

Moog Global Support

Moog Global Support is our promise to offer world-class Repair and Maintenance Services delivered expertly by our trained technicians. With the reliability only available from a leading manufacturer with facilities around the world, Moog offers you service and expertise you can count on to keep your equipment operating as it should.

This promise offers many benefits to our customers including:

- Reduce your downtime by keeping critical machines running in peak performance
- Protect your investment by ensuring reliability, versatility and long-life of products
- Better plan your maintenance activities and make systematic upgrades
- Leverage our flexible programs to meet the unique service requirements of your facility

Look to Moog for global support including:

- Repair services using OEM parts are performed by trained technicians to the latest specifications
- Stock management of spare parts and products to prevent unplanned downtime

- Flexible programs, tailored to your needs such as upgrades, preventative maintenance and annual/multi-year contracts
- On-site services bring the expertise to you, providing quicker commissioning, set-up and diagnostics
- Access to reliable services that are guaranteed to offer consistent quality anywhere in the world

For more information on Moog Global Support visit www.moog.com/industrial/service.



ORDERING CODE

Type designation

1	2	3	4	5	6	7	8	9	10	11	12
	-	C	C	E		6			X		/ ...

1 Seal materials

N	NBR (Standard)
M	Mixed (FKM + PU ¹)
T	Mixed (NBR + PU ¹)
V	FKM

¹) PU = Polyurethane

2 Valve type

C	Cartridge valve
---	-----------------

3 Function

C	Cartridge cover
---	-----------------

4 Cover unit connection type

E	Manifold installation
---	-----------------------

5 Size

16	ISO 7368-BA-06-2-A
25	ISO 7368-BB-08-2-A
32	ISO 7368-BC-09-2-A
40	ISO 7368-BD-10-2-A
50	ISO 7368-BE-11-2-A
63	ISO 7368-BF-12-2-A
80	ISO 7368-BG-13-2-A
100	ISO 7368-BH-14-2-A

6 Series²)

	Pressure range
D	350 bar (5,000 psi) - except 1H cover
F	350 bar (5,000 psi) - 1H only
K	420 bar (6,000 psi)

²) Please refer to the product overview table in the introduction section

7 Manifold interface

6	ISO 7368
---	----------

12 Options

...	Orifice configuration: Orifice diameter is given in 10th of mm. Example: X08;Y00 = orifice 0,8 mm in X and plug in Y See page 55 for more details.
-----	--

11 Pilot valve interface

06	ISO 4401-03-02-0-05
10	ISO 4401-05-04-0-05
99	Without interface

10 Pilot oil connection

X	All ports through cover interface
---	-----------------------------------

9 Adjustment

0	Without adjustment
2	Spindle with hex nut and lock nut ³)
9	Spindle with hex nut, lock nut and protective sleeve, tamper proof seal included separately ³)

³) 1H cover only

8 Cover code

1D		1W		2WR	
1H		1WDB		4W	
RM		2D		RV	
DRE		2W		More cover types available on request	

TAKE A CLOSER LOOK.

Moog designs a range of motion control products that complement the performance of those featured in this document. Visit our website for more information and contact the Moog facility nearest you.

Argentina
+54 11 4326 5916
info.argentina@moog.com

India
+91 80 4057 6666
info.india@moog.com

Singapore
+65 677 36238
info.singapore@moog.com

Australia
+61 3 9561 6044
info.australia@moog.com

Ireland
+353 21 451 9000
info.ireland@moog.com

South Africa
+27 12 653 6768
info.southafrica@moog.com

Brazil
+55 11 3572 0400
info.brazil@moog.com

Italy
+39 0332 421 111
info.italy@moog.com

Spain
+34 902 133 240
info.spain@moog.com

Canada
+1 716 652 2000
info.canada@moog.com

Japan
+81 46 355 3767
info.japan@moog.com

Sweden
+46 31 680 060
info.sweden@moog.com

China
+86 21 2893 1600
info.china@moog.com

Korea
+82 31 764 6711
info.korea@moog.com

Switzerland
+41 71 394 5010
info.switzerland@moog.com

Finland
+358 10 422 1840
info.finland@moog.com

Luxembourg
+352 40 46 401
info.luxembourg@moog.com

Turkey
+90 216 663 6020
info.turkey@moog.com

France
+33 1 4560 7000
info.france@moog.com

The Netherlands
+31 252 462 000
info.thenetherlands@moog.com

United Kingdom
+44 (0) 1684 858000
info.uk@moog.com

Germany
+49 7031 622 0
info.germany@moog.com

Norway
+47 6494 1948
info.norway@moog.com

USA
+1 716 652 2000
info.usa@moog.com

Hong Kong
+852 2 635 3200
info.hongkong@moog.com

Russia
+7 831 713 1811
info.russia@moog.com

www.moog.com/industrial

Moog is a registered trademark of Moog Inc. and its subsidiaries.
All trademarks as indicated herein are the property of Moog Inc. and its subsidiaries.
©2014 Moog Inc. All rights reserved. All changes are reserved.

Cartridge Covers
PIM/Rev. A, December 2014, CDL34560-en