

HYDRAULIC SERVICE MANIFOLD

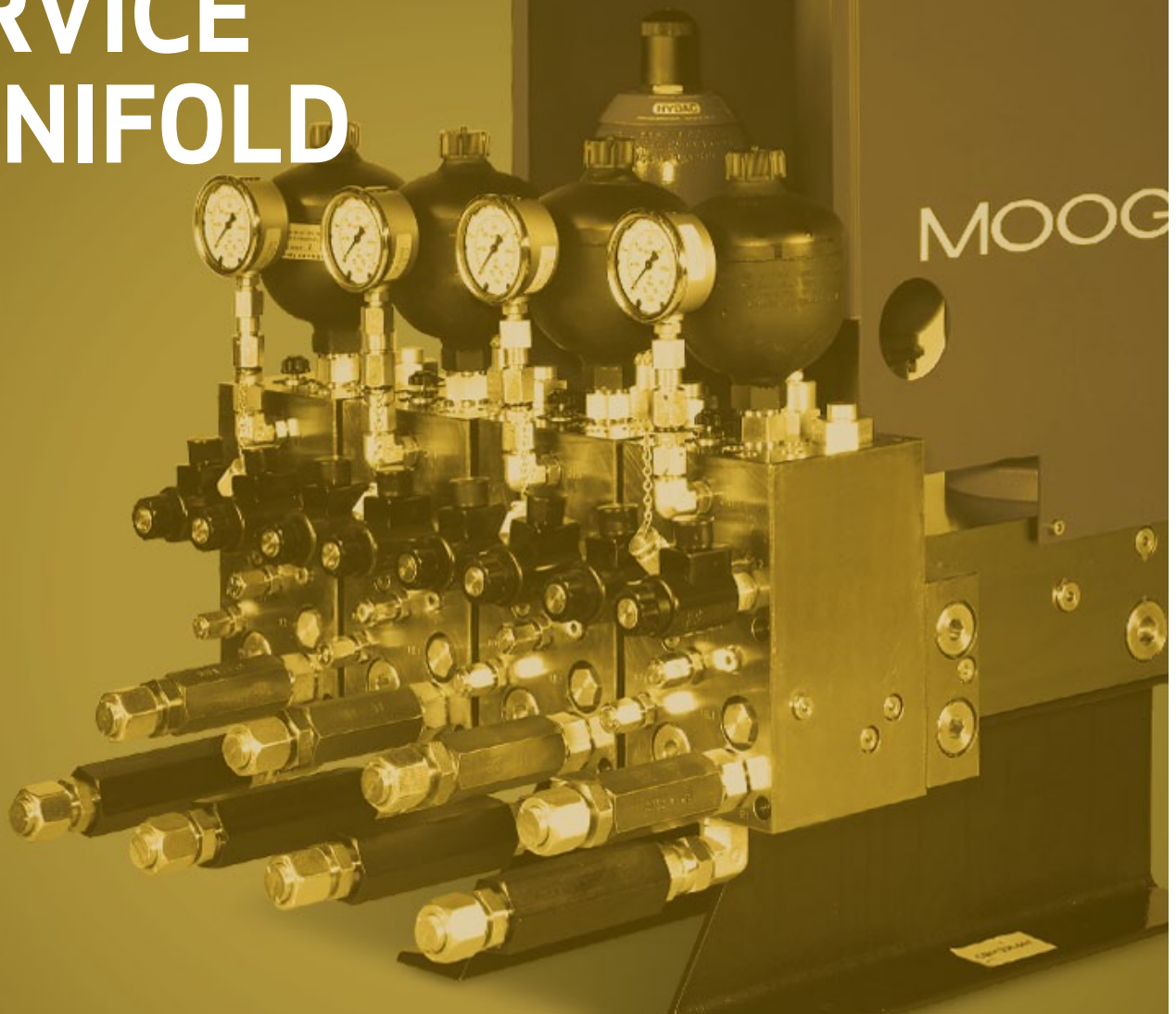

Rev.-, October 2011

ON/OFF ISOLATION CONTROL
FOR TEST SYSTEMS AND
HYDRAULIC ACTUATORS

Whenever the highest levels of motion control performance and design flexibility are required, you'll find Moog expertise at work. Through collaboration, creativity and world-class technological solutions, we help you overcome your toughest engineering obstacles. Enhance your machine's performance, achieve greater efficiencies and help take your thinking further than you ever thought possible.

INTRODUCTION

Overview..... 2

TECHNICAL DATA

Specifications 5

Dimensions..... 6

ORDERING INFORMATION

Spare Parts Lists..... 6

Ordering Code..... 7



This catalog is for users with technical knowledge. To ensure that all necessary characteristics for function and safety of the system are given, the user has to check the suitability of the products described herein. The products described herein are subject to change without notice. In case of doubt, please contact Moog.

Moog is a registered trademark of Moog Inc. and its subsidiaries. All trademarks as indicated herein are the property of Moog Inc and its subsidiaries. For the full disclaimer refer to www.moog.com/literature/disclaimers.

For the most current information, visit www.moog.com/industrial or contact your local Moog office.

©Moog Inc. 2011. All rights reserved. All changes are reserved.

PRODUCT OVERVIEW

Introducing the Moog Hydraulic Service Manifold

The Moog Hydraulic Service Manifold (HSM) provides an on/off isolation control to a test system or individual hydraulic actuator. The input side of the HSM is connected to a central Hydraulic Power Unit (HPU). The output side is connected to one or more servo controlled hydraulic actuators. It also provides additional filtration and has accumulators for removing pressure and flow fluctuation and storing energy.

When energized it provides a controlled hydraulic pressurization to the test system without damaging the specimen. Moog offers several different sizes of HSM units rated in liters per minute -80, 200, 400, 880, 1200 lpm. The -80 and 1200 lpm models are single station units. HSM's sizes- 200, 400, 880 lpm models are also available in one through four channels. Custom hydraulic control manifolds are available upon request.

The Moog HSM follows the testing industry convention with the following control logic:

- When no solenoids are energized, the system will have no flow.
- The low pressure solenoid is energized for low pressure operation.
- The low and high pressure solenoids must both be energized for high pressure operation.

Features	Benefits
Independent pressure control	Provides complete, independent control of hydraulic pressure applied to individual stations or systems operating from a single hydraulic power supply.
Smooth, adjustable pressure transition time (5-9 seconds) between low to high and high to low pressure modes	Enhances safety and permits predictable system control.
Rapid response pressure reduction	Helps protect the specimen, test system and personnel in the event of an abnormal condition by quickly removing hydraulic pressure applied to the system.
A main filter protects components by preventing the passage of dirt particles that might enter the system as a result of opening hydraulic lines or adding hydraulic fixtures.	Helps ensure clean hydraulic fluid.
Five models provide a choice of five flow rates from 80 up to 1200 lpm (21 to 316 gpm)	Allows flexibility to select the flow you need.
HSM 80 pressure drop is below 2MPa at maximum 80 lpm flow rate , others models pressure drop is about 2 MPa at maximum flow.	Lower pressure drop
24 VDC control signal	Each station needs two 24 VDC , maximum 1.5 A control signal.

Flexibility

Moog offers three sizes of control modules which can be selected for multi-station applications. Each control module is one independently controlled station. They can delivery up to 100 lpm, 200 lpm and 400 lpm of flow separately. See the chart below.

Control Module for Multi-Station			
	Two Stations	Three Stations	Four Stations
HSM 200	Two 100 lpm Modules	Three 100 lpm Modules	Four 100 lpm Modules
HSM 400	Two 200 lpm Modules	Three 200 lpm Modules	Four 100 lpm Modules
HSM 880	Two 400 lpm Modules	Three 400 lpm Modules	Four 200 lpm Modules

Options

- Pilot line module can be selected for HSM 200, HSM 400, and HSM 880 and HSM 1200.

- Up to 101 bladder type accumulator
- SAE 37° FLARE (ISO 8434-2) and DIN 24° cone (ISO 8434-1) hydraulic interface fitting

The designed flow rate of this line is 40 lpm which contains 3 µm absolute filter, check valve, pressure gage and 0.5l accumulator. There is normally a closed shut-off solenoid valve with 24 VDC, 1.5 A maximum as an option for this line.

HSM Block Diagram

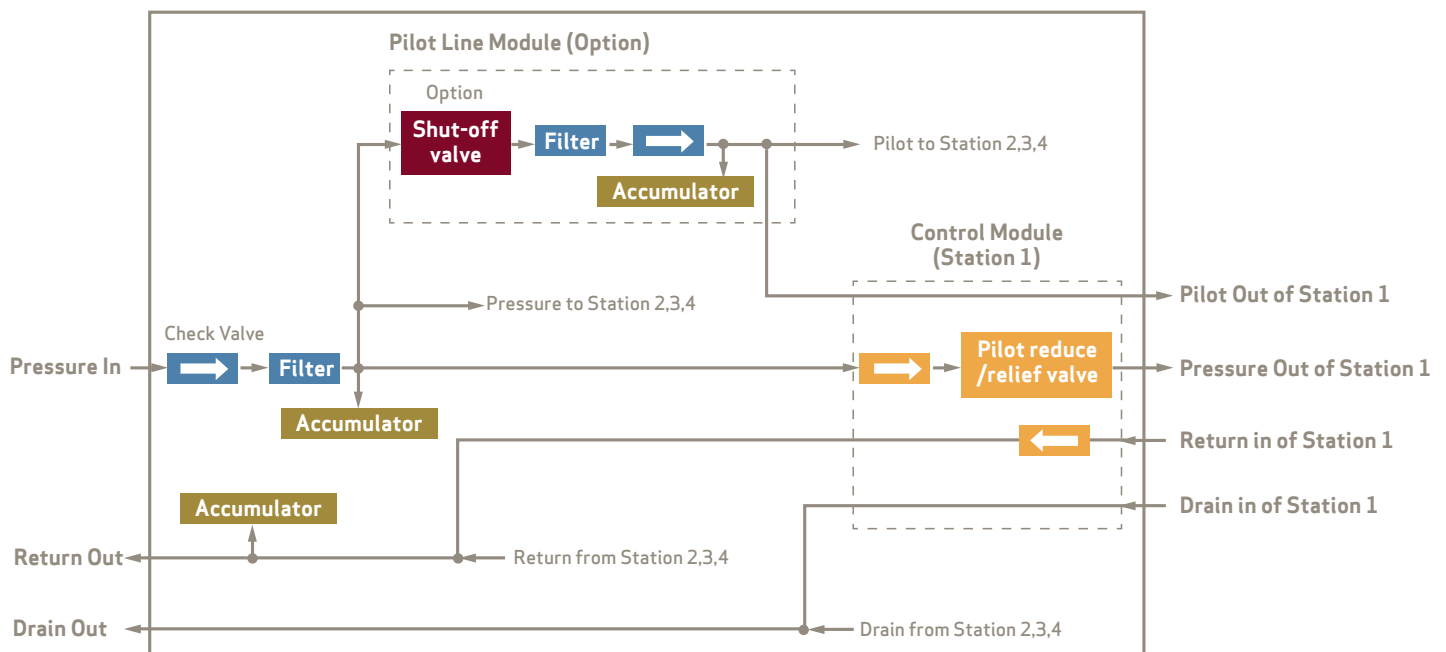

Specifications

	HSM 80	HSM 200	HSM 400	HSM 880	HSM 1200
Number of Stations	1	1-4	1-4	1-4	1
Operating Pressure	21 MPa (3,000 psi)	21 MPa (3,000 psi)	21 MPa (3,000 psi)	21 MPa (3,000 psi)	21 MPa (3,000 psi)
Nominal Flow	80 lpm (21 gpm)	200 lpm (53 gpm)	400 lpm (105 gpm)	880 lpm (232 gpm)	1200 lpm (316 gpm)
Variable Low Pressure	1 -21 MPa (150-3,000 psi)	1 -21 MPa (150-3,000 psi)	1 -21 MPa (150-3,000 psi)	1 -21 MPa (150-3,000 psi)	1 -21 MPa (150-3,000 psi)
Low/Hi, Hi/Low Ramp Time (adjustable)	5.0 – 9.0 sec	5.0 – 9.0 sec	5.0 – 9.0 sec	5.0 – 9.0 sec	5.0 – 9.0 sec
Solenoid Current	1.5 A maximum (24 VDC)	1.5 A maximum (24 VDC)	1.5 A maximum (24 VDC)	1.5 A maximum (24 VDC)	1.5 A maximum (24 VDC)
Pressure Line Accumulator	1 l**	2.5 l**	2.5 l**	10 l**	10 l**
Return Line Accumulator	0.5 l**	1 l**	1 l**	4 l**	4 l**
Pilot Line Accumulator	N/A	0.5 l	0.5 l	0.5 l	0.5 l
Pressure Line Filter ($\beta_{20} \geq 150$)	20 μ m	20 μ m	20 μ m	20 μ m	20 μ m
Pilot Line Filter ($\beta_3 \geq 200$)	N/A	3 μ m	3 μ m	3 μ m	3 μ m
Pressure Port	Seal-Lok™ -12	Seal-Lok™ -16	Seal-Lok™ -24	SAE Code 61 -32	SAE Code 61 -32
Return Port	Seal-Lok™ -12	Seal-Lok™ -16	Seal-Lok™ -24	SAE Code 61 -32	SAE Code 61 -32
Pilot Port	N/A	Seal-Lok™ -6	Seal-Lok™ -6	Seal-Lok™ -6	Seal-Lok™ -6
Drain Port	Seal-Lok™ -6	Seal-Lok™ -6	Seal-Lok™ -6 in /-8 out	Seal-Lok™ -6 in /-8 out for multi-station -8 in /-8 out for single-station	Seal-Lok™ -8

Note :

100 lpm module for multi station : Pressure out Seal-Lok™ -12 , return in Seal-Lok™ -12

200 lpm module for multi station : Pressure out Seal-Lok™ -16 , return in Seal-Lok™ -16

400 lpm module for multi station : Pressure out Seal-Lok™ -24 , return in Seal-Lok™ -24

Seal material: NBR.

All filters with visual clog indicator.

Pressure gauge is provided on pilot line module and each station's pressure out port.

* Moog recommends the use of SAE O-Ring Face Seal (ORFS) 'Seal-Lok™' ISO 8434-3 for the best leak-free connection; SAE 37° FLARE (ISO 8434-2) and DIN 24° cone (ISO 8434-1) hydraulic interface fitting can be selected as an option.

** This is Moog recommended accumulator size. Other accumulator size on pressure line and return line can be selected. See ordering information.

Operating Temperature

The ambient air temperature range must be within a range of +15 to 40° C (+60 to 120° F).

The hydraulic oil temperature should be maintained between +24 to 57° C (+75 to 135° F).

Oil Requirements

System fluid: Mobil DTE-24, 25, Shell Tellus 32, 46 or equivalent

Cleanliness level: ISO 4406 (SAE J1165) 15/14/11 (NAS 5)

Dimensions and Weights

		HSM 80	HSM 200				HSM 400				HSM 880				HSM 1200
Station		1	1	2	3	4	1	2	3	4	1	2	3	4	1
Weight	kg	80	200	220	255	290	210	240	275	295	580	532	593	589	593
	b	176	441	485	562	639	463	529	606	650	1279	1173	1307	1299	1307
Height (H)	mm	546	739	739	739	739	887	887	887	887	948	948	948	948	948
	in	21	29	29	29	29	35	35	35	35	37	37	37	37	37
Width (W)	mm	265	330	330	446	560	330	330	453	568	712	712	712	712	712
	in	10	13	13	18	22	13	13	18	22	28	28	28	28	28
Depth (D)	mm	265	510	510	533	533	510	510	553	553	885	836	836	786	885
	in	10	20	20	21	21	20	20	22	22	35	33	33	31	35

Hydraulic Service Manifold Structure

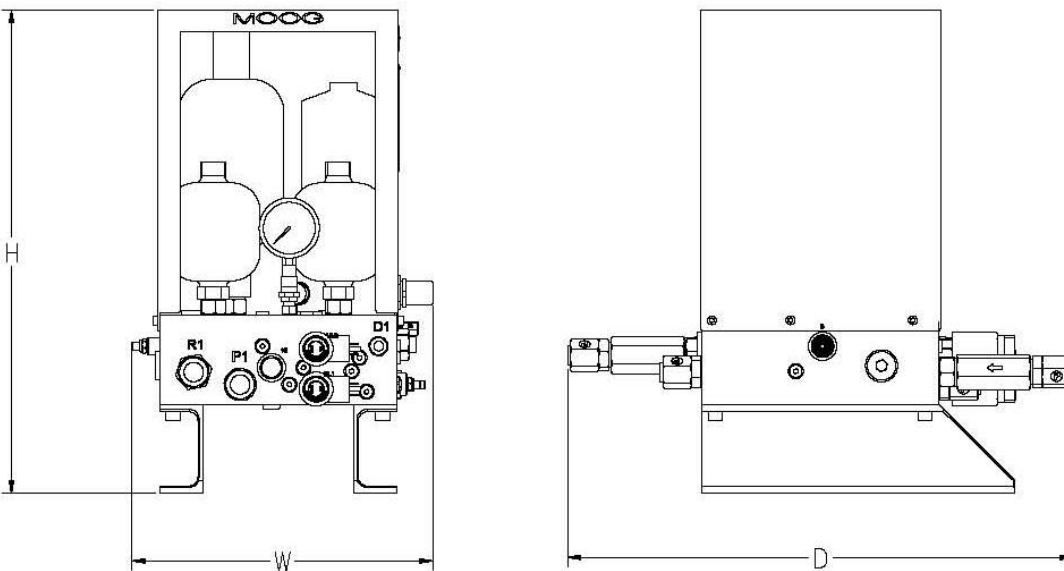

Spare Part List and Tool

Item	Moog Part Number	Note
Filter Elements of HSM 80's Pressure Line (20µm)	CA85236-0240-020	
Filter Elements of HSM 200's Pressure Line (20µm)	CA85236-0330-020	
Filter Elements of HSM 400's Pressure Line (20µm)	CA85236-0500-020	
Filter Elements of HSM 880's Pressure Line (20µm)	CA85236-0500-020	need 2 pieces /unit
Filter Elements of HSM 1200's Pressure Line (20µm)	CA85236-0500-020	need 2 pieces /unit
Filter Elements of Pilot Line (3µm)	CA85236-0110-003	
Shut-off Valve of Pilot Line	CA84147-004	
Control Solenoid Valve with Coil	CB39795-001	need 2 piece /station
Coil of Control Solenoid Valve	CB18903-001	24 VDC
Accumulator Charging Kit	CA85351-001	

Ordering Information

C 0 5 0 - 4 X X X - X X X X X X X X

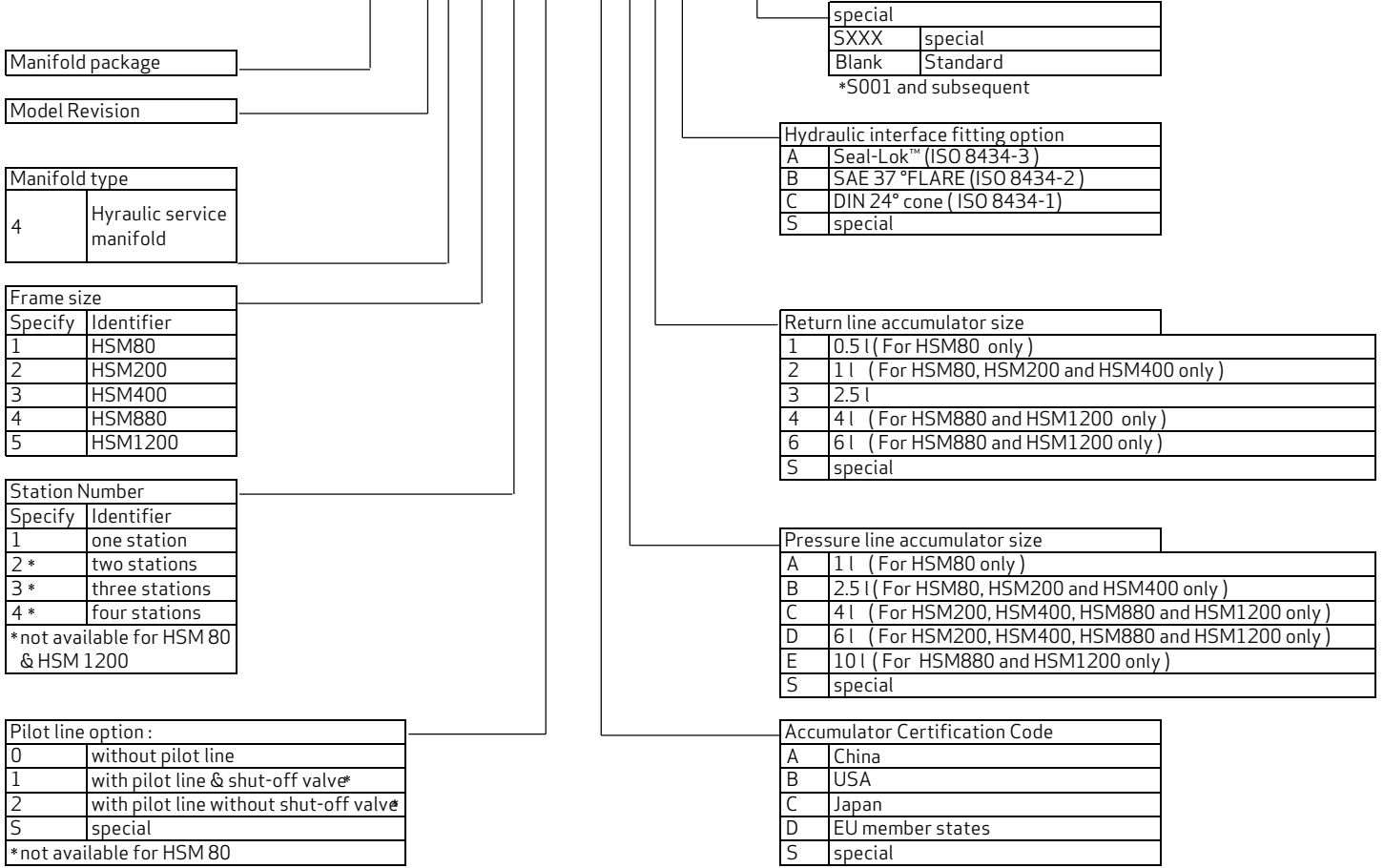

Notes:

1. Moog recommends and uses bladder type accumulator, only 0.5 l is diaphragm type.
2. SAE 37° FLARE (ISO 8434-2) and DIN 24° cone (ISO 8434-1) hydraulic interface fitting can be provided as an option.
3. For special requirements, please consult with Moog.

TAKE A CLOSER LOOK.

Moog designs a range of products that complement the performance of those featured in this catalog. Visit our website for more information and the Moog facility nearest you.

Argentina
+54 11 4326 5916
info.argentina@moog.com

India
+91 80 4057 6605
info.india@moog.com

Singapore
+65 677 36238
info.singapore@moog.com

Australia
+61 3 9561 6044
info.australia@moog.com

Ireland
+353 21 451 9000
info.ireland@moog.com

South Africa
+27 12 653 6768
info.southafrica@moog.com

Brazil
+55 11 3572 0400
info.brazil@moog.com

Italy
+39 0332 421 111
info.italy@moog.com

Spain
+34 902 133 240
info.spain@moog.com

Canada
+1 716 652 2000
info.canada@moog.com

Japan
+81 46 355 3767
info.japan@moog.com

Sweden
+46 31 680 060
info.sweden@moog.com

China
+86 21 2893 1600
info.china@moog.com

Korea
+82 31 764 6711
info.korea@moog.com

Switzerland
+41 71 394 5010
info.switzerland@moog.com

Finland
+358 9 2517 2730
info.finland@moog.com

Luxembourg
+352 40 46 401
info.luxembourg@moog.com

United Kingdom
+44 168 429 6600
info.uk@moog.com

France
+33 1 4560 7000
info.france@moog.com

The Netherlands
+31 252 462 000
test@moog.com

USA
+1 716 652 2000
info.usa@moog.com

Germany
+49 7031 622 0
info.germany@moog.com

Norway
+47 6494 1948
info.norway@moog.com

Hong Kong
+852 2 635 3200
info.hongkong@moog.com

Russia
+7 8 31 713 1811
info.russia@moog.com

www.moog.com/industrial

Moog is a registered trademark of Moog Inc. and its subsidiaries.
All trademarks as indicated herein are the property of Moog Inc.
and its subsidiaries.
Seal-Lok™ is a registered trademark of Packer Hannifan Corporation.

©2012 Moog Inc. All rights reserved. All changes are reserved.

Hydraulic Service Manifold
Mobium/PDF/Rev. -, January 2012, Id. CDL33164-en