

DIRECT DRIVE DIGITAL CONTROL PROPORTIONAL VALVES

D637 SERIES

ISO 4401 SIZE 05



Rev. A, November 2017

OFFERING FULL DIGITAL FUNCTIONALITY, HIGH
PERFORMANCE CONTROL AND ACCURATE
POSITIONING

WHAT MOVES YOUR WORLD

MOOG

Whenever the highest levels of motion control performance and design flexibility are required, you'll find Moog expertise at work. Through collaboration, creativity and world-class technological solutions, we help you overcome your toughest engineering obstacles. Enhance your machine's performance. And help take your thinking further than you ever thought possible.

INTRODUCTION.....	2
Product Overview	3
Features and Benefits.....	4
Description of Operation	5
TECHNICAL DATA	7
SIZE 05 - D637 PROPORTIONAL VALVE.....	7
Electronics	11
BACKGROUND	17
Flow Calculation	17
Electronics	18
Fieldbus Interface.....	19
Configuration Software.....	20
ORDERING INFORMATION.....	21
Accessories and Spare Parts.....	21
Accessories - Installation Drawings.....	23
About Moog.....	25
Solutions	26
Moog Global Support.....	27
Ordering Code	30

This catalog is for users with technical knowledge. To ensure all necessary characteristics for function and safety of the system, the user has to check the suitability of the products described herein. The products described herein are subject to change without notice. In case of doubt, please contact Moog.

Moog is a registered trademark of Moog Inc. and its subsidiaries. All trademarks as indicated herein are the property of Moog Inc. and its subsidiaries. For the full disclaimer refer to www.moog.com/literature/disclaimers.

For the most current information, visit www.moog.com/industrial or contact your local Moog office.

All dimensions in mm (in)

PRODUCT OVERVIEW

Moog Digital Control Proportional Valves (DCV) are closed-loop hydraulic valves that are used in industrial machinery to precisely control fluid flow, pressure, position or force in 4-, 3- and 2x2-way applications.

The D637 series size 05 is a direct drive proportional valve for flow (Q) control. This valve series has world-class technology that makes it the performance leader in providing advanced functionality such as higher dynamics, easy parameter tuning and adaptation of flow characteristics. For maximum flexibility, customers can choose to have an analog interface, fieldbus interface (e.g. EtherCAT, PROFIBUS-DP, CANopen) or both combined in the same valve.

With a robust design that offers proven reliability in some of the world's most demanding environments such as oil rigs, offshore wind turbines and steel mills, these valves can be tailored to your exact performance requirements. With proven hydraulic motion control and application expertise, Moog's engineers help you select the version that best meets your needs.

D637 Series Proportional Valve

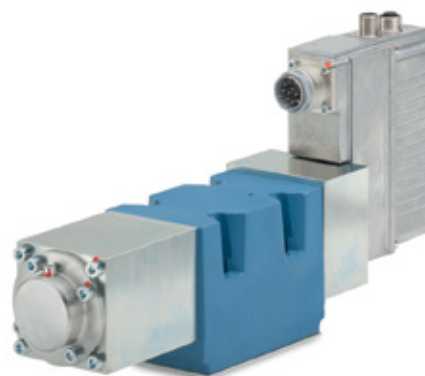

Explosion-proof Valves

This series also has a version certified for use in potentially hazardous environments (e.g. explosion-proof) with hot-swappable connectors and proven ability to withstand vibration and heavy use. Equipment protection with flameproof enclosures “d” and increased safety “e” with marking: II 2G Ex de IIC T5/T4/T3 Gb. For explosion proof valves technical data (outer dimensions and wiring) please contact Moog.

Axis Control Valve (ACV)

Axis control functionality can also be added to the valve enabling closing of the external control loop and decentralized control in an automation system, all within the valve device. Data from external sensors can be evaluated by up to 3 analog inputs: (V/A), SSI or Wheatstone Bridge.

For more information please contact our application engineers for assistance.

	D637 Proportional Valve
Valve design	1-stage, with spool in body
Size according ISO 4401	05
Mounting pattern	ISO 4401-05-05-0-05
Rated flow at Δp_N 5 bar (75 psi)/spool land	24/40/60 l/min (6.3/10.6/15.9 gpm)
Rated flow at Δp_N 35 bar (500 psi)/spool land	60/100/160 l/min (15.9/26.4/42.3 gpm)
Maximum flow	180 l/min (47.6 gpm)
Maximum operating pressure - port P, A, B	350 bar (5,000 psi)
Step response time for 0 to 100 % stroke	20 ms

FEATURES AND BENEFITS

Features	Benefits
All Digital Control Valves (DCV)	
Exactly tailored hardware, configuration and functionality to the customer's application needs	Optimizes machine performance to gain competitive advantages
High performance design of hardware and software with improved dynamics compared to traditional proportional valve technology	Increases acceleration, improves accuracy and enhances machine productivity
ATEX and IECEx approved versions with hot-swappable connectors and vibration resistance	Qualifies proven, reliable products for use in hazardous environments such as oil and gas production
EtherCAT, PROFIBUS and CANopen fieldbus communications	Reduces cabling and the number of analog input/output (I/O) modules, saves space and costs while obtaining more machine flexibility Allows quick commissioning and tuning that can be easily integrated in the customer's machine automation system
Diagnostic, condition monitoring of data in the valve and advanced tuning functionality via Moog Software	Supports machine optimization and tailoring exactly to customer specifications Helps customers manage life cycle of the valve in order to optimize maintenance costs
Factory preset of all relevant parameters	Enables plug-and-play to replace valves
All Direct Drive Valves (DDV)	
Direct drive with permanent magnet linear force motor	Provides high actuation force, working in 2 directions and reliable control in many demanding applications
Pilot oil not required	Saves energy costs
Pressure-independent dynamic response	Guarantees constant product quality
D637 Proportional Valve	
Higher rated flow than a servo valve of comparable size	Increases actuator speed with a dynamic performance close to that of a servo valve
Higher actuation force than proportional solenoid driven valves	Improves dynamics and operating limit

DESCRIPTION OF OPERATION

Proportional Valve Operation Mode

The D637 Proportional Valve provides flow control (Q). In this operating mode the position of the spool is controlled. The command signal corresponds to a particular spool position.

The command signal (spool position) is transmitted to the valve electronics. The actual spool position is measured with a position transducer and transmitted to the valve electronics. The electronics compares the actual spool position and command signal and generates a signal to drive the linear force motor, which moves the spool into the corresponding position.

The position command can be easily modified by adjusting parameters in the valve software (e.g. linearization, ramping, dead band, sectionally defined amplification, etc.).

Direct Drive Proportional Valve with Integrated Digital Electronics

- Fieldbus data transfer: Electrically isolated fieldbus interface
- Diagnostic capabilities: Integrated monitoring of important ambient and internal data. Valve parameters can be changed on site or remotely
- Flexibility: Since parameters may be downloaded using the fieldbus or a high level PLC program, valve parameters may be tuned during a machine cycle while the machine is operating
- Low hysteresis and high response characteristics
- Low power demand at the proximity of hydraulic zero position. Hydraulic zero is the spool position at which the pressures of a symmetrical spool are equal in both blocked control ports
- If the electrical supply fails, a cable breaks or emergency stop is activated, the spool returns to the predefined spring-centered position (fail-safe) without passing a fully open control port position resulting to an increasing safety.

D637 Series Direct Drive Proportional Valve

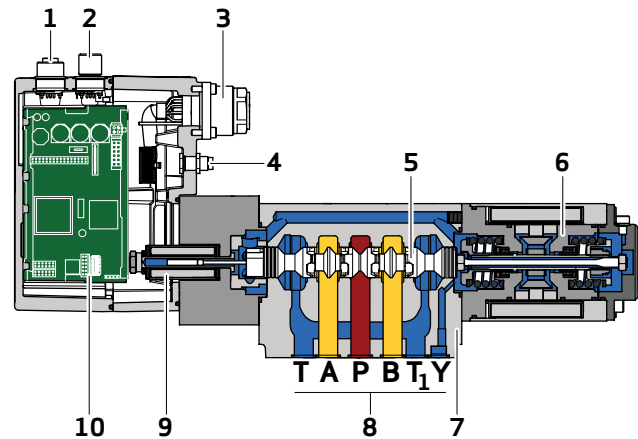

- 1 Fieldbus connector X4
- 2 Fieldbus connector X3
- 3 Valve connector X1
- 4 Service connector X10
- 5 Spool
- 6 Linear force motor
- 7 Valve body
- 8 Ports
- 9 Position transducer (LVDT)
- 10 Digital electronics

DESCRIPTION OF OPERATION

Permanent Magnet Linear Force Motor

The linear force motor is a permanent magnet excited differential motor.

Some of the magnetic force is already provided by the permanent magnets. The linear force motor's power demand is thus significantly lower than with a comparable proportional solenoid.

The linear force motor drives the servo valve's spool.

The spool starting position is determined in the de-energized state by the centering springs. The linear force motor enables the spool to be deflected from the starting position in both directions. The actuating force of the linear force motor is proportional to the coil current.

The high force level of the linear force motor and centering springs effect precise spool movement even against high flow and frictional forces.

D637 Series Linear Motor

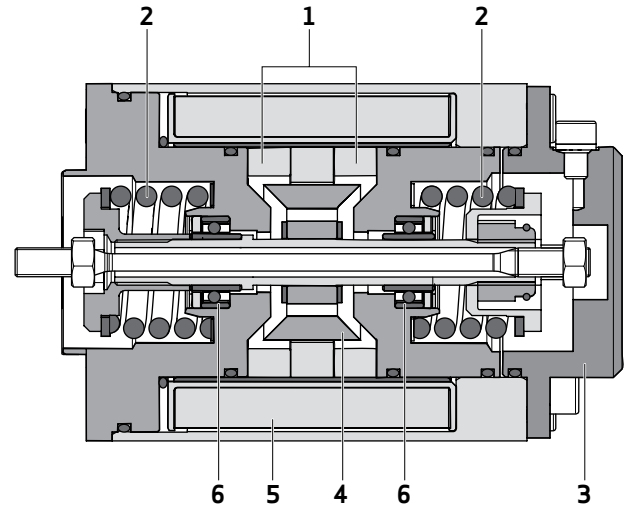

- 1 Permanent magnets
- 2 Centering springs
- 3 Cover
- 4 Armature
- 5 Coil
- 6 Bearing

SIZE 05 - D637 PROPORTIONAL VALVE

Measured at 140 bar (2,000 psi) system pressure, 32 mm²/s (32 cSt) oil viscosity and +40 °C (+104 °F) oil temperature.

General Technical Data

Valve design	1-stage, with spool in body
Mounting pattern	ISO 4401-05-05-0-05
Installation position	Any
Weight	7.9 kg
Storage temperature range	-40 to +80 °C (-40 to +176 °F)
Ambient temperature range	-20 to +60 °C (-4 to +140 °F)
Vibration resistance	30 g, 3 axis, 10 Hz to 2 kHz
Shock resistance	50 g, 6 directions, 3 ms
MTTF_d value according to EN ISO 13849-1	150 years

Hydraulic Data

Maximum operating pressure			
Port P, A, B	350 bar (5,000 psi)		
Port T without Y	50 bar (725 psi)		
Port T with Y	210 bar (3,000 psi)		
Port Y	Depressurized to tank ¹⁾		
Rated flow at Δp_N 5 bar (75 psi)/spool land	24 l/min (6.3 gpm)	40 l/min (10.6 gpm)	60 l/min (15.9 gpm)
Maximum flow	180 l/min (47.6 gpm)		
Leakage flow (\approx zero lap)	1.2 l/min (0.32 gpm)	2 l/min (0.5 gpm)	3 l/min (0.8 gpm)
Hydraulic fluid	Hydraulic oil as per DIN 51524 parts 1 to 3 and ISO 11158. Other fluids upon request.		
Temperature range	-20 to +80 °C (-4 to +176 °F)		
Viscosity range			
Recommended viscosity range at 38 °C (100 °F)	15 to 100 mm ² /s (cSt)		
Maximum permissible viscosity range at 38 °C (100 °F)	5 to 400 mm ² /s (cSt)		
Recommended cleanliness class as per ISO 4406			
For functional safety	18/15/12		
For longer service life	17/14/11		

Typical Static and Dynamic Data

Step response time for 0 to 100 % stroke	20 ms
Threshold, typical	< 0.05 %
Threshold, maximum	< 0.1 %
Hysteresis, typical	< 0.05 %
Hysteresis, maximum	< 0.1 %
Null shift at $\Delta T = 55 K (131 °F)$	< 1.5 %
Sample deviation of rated flow	< 3 %

1) In order to avoid an emptying of the return line, a back-pressure of 2 bar (29 psi) should be maintained on the T, T1 and Y connections.

SIZE 05 - D637 PROPORTIONAL VALVE

Electrical Data

Duty cycle	100 %
Degree of protection according to IEC/EN 60529	IP65 (with mounted mating plugs)
Supply voltage⁵⁾	24 V _{DC} (18 to 32 V _{DC})
Permissible ripple of supply voltage⁶⁾	±3 V _{RMS}
Maximum current consumption⁷⁾	3.0 A
Power consumption of the valve in middle position	9.6 W (0.4 A at 24 V _{DC})
Power consumption maximum	55.2 W (2.3 A at 24 V _{DC})
Fuse protection, external, per valve	3.15 A (slow)
EM compatibility	<ul style="list-style-type: none"> Emitted interference as per DIN EN 61000-6-4 (CAN open and PROFIBUS-DP) Emitted interference as per DIN EN 61000-6-3 (EtherCAT) Immunity to interference as per EN 61000-6-2 (evaluation criterion A)

5) All connected circuits must be isolated from the mains supply by “electrical separation” in accordance with IEC/EN 61558-1 and IEC/EN 61558-2-6. Voltages must be limited to the safety extra-low voltage range in accordance with EN 60204-1. We recommend the use of SELV/PELV power packs.

6) Frequency from 50 Hz to 10 kHz

7) Measured at +25 °C (+77 °F) ambient temperature and 24 V supply voltage

Installation drawing

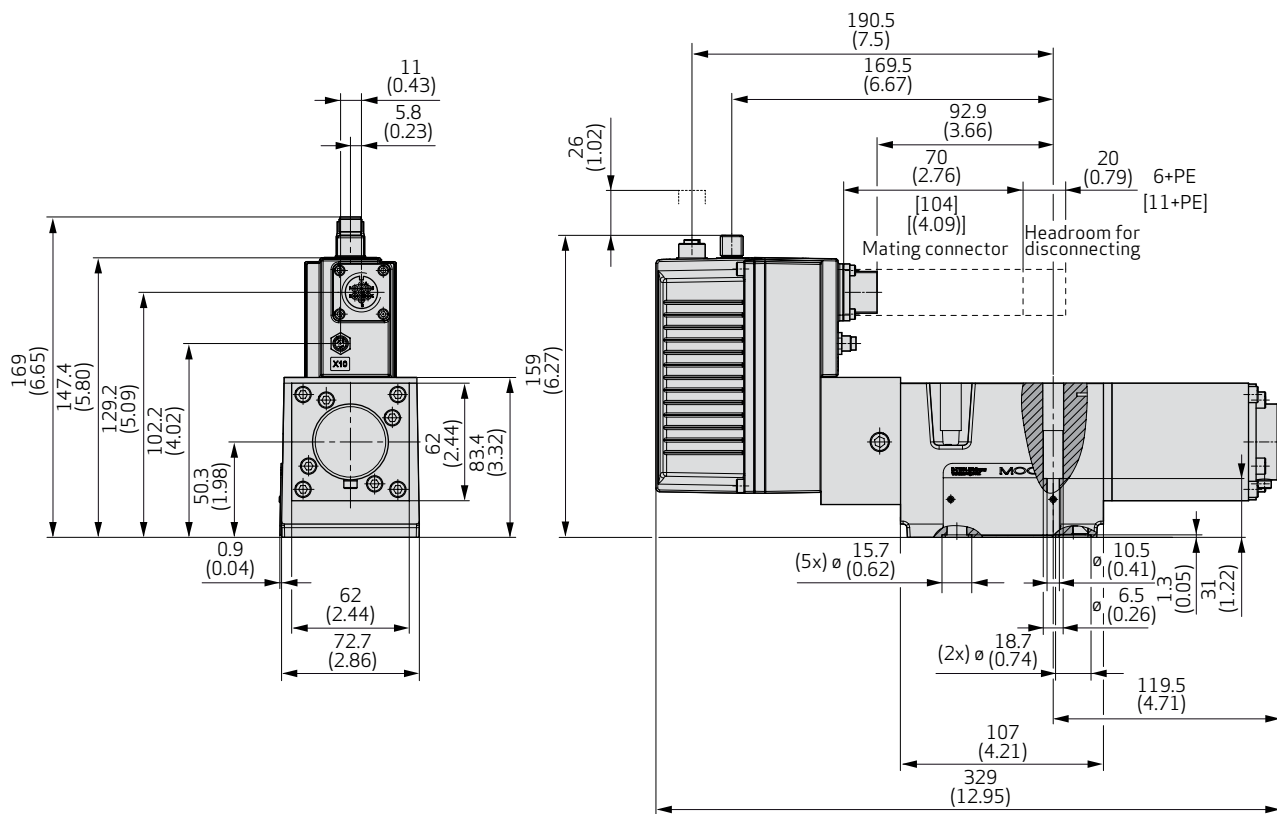

Note: See section “Installation Drawing Electronic Housing” for valves with fieldbus interface.

SIZE 05 - D637 PROPORTIONAL VALVE

Step Response

24, 40 and 60 l/min (6.3, 10.6 and 15.9 gpm)

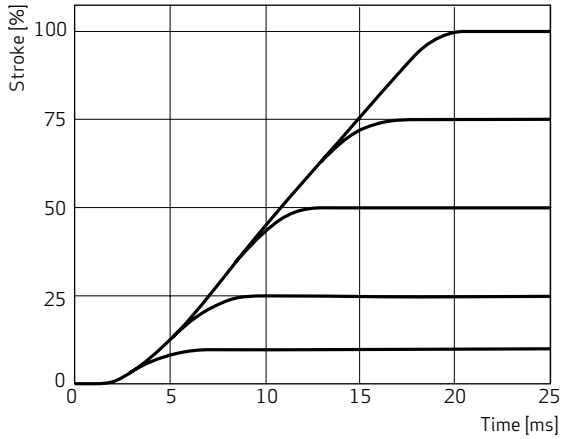

Frequency Response

24, 40 and 60 l/min (6.3, 10.6 and 15.9 gpm)

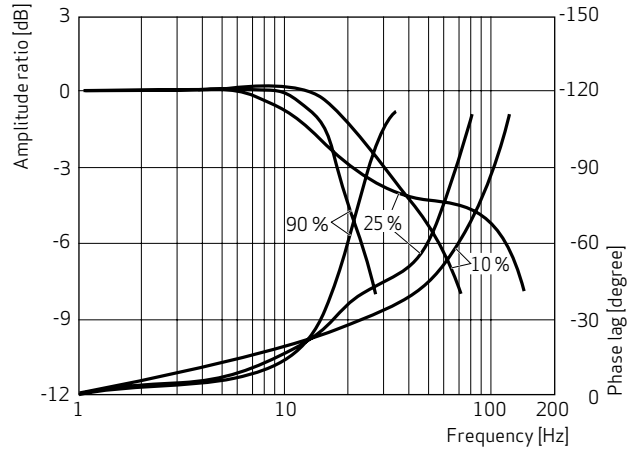

Flow Signal

Flow signal characteristic

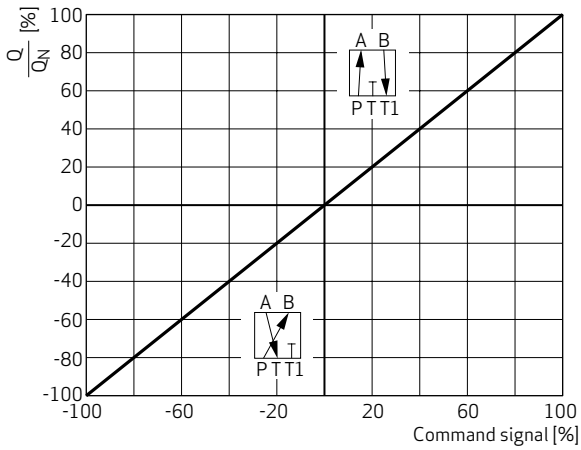

Pressure signal

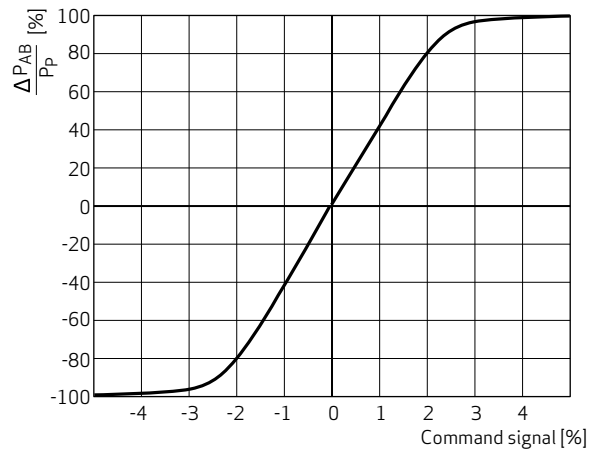

SIZE 05 - D637 PROPORTIONAL VALVE

Typical Characteristic Curves

Flow signal curves at $\Delta p_N = 35$ bar (500 psi) per spool land

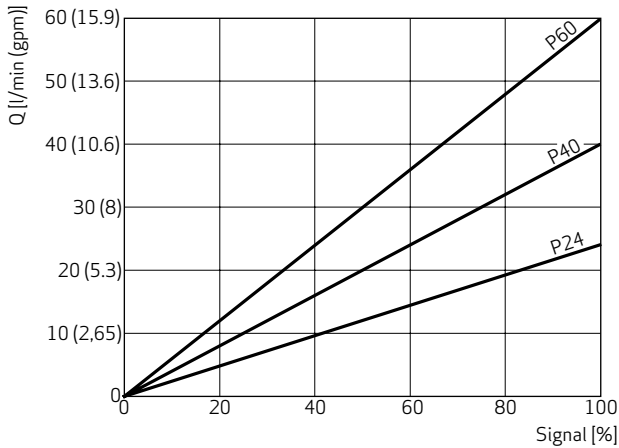

Hydraulic Symbol

2x2-way operation

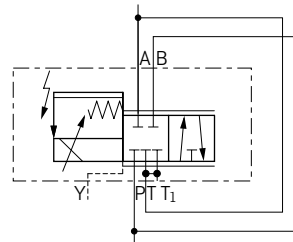

3-way operation

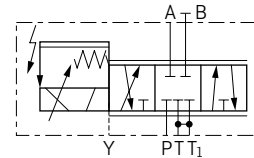

4-way operation

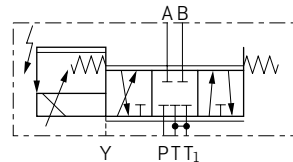

Hole Pattern of Mounting Surface

The mounting pattern must correspond to ISO 4401-05-05-0-05 with port T_1 without port X. Observe mounting length of minimum 100 mm (3.94 in) and O-ring recess for port Y. For 4-way valves with $Q > 60$ l/min (15.9 gpm) the second tank port T_1 is required.

For maximum flow the ports for P, T, T_1 , A and B must be designed with $\varnothing 11.5$ mm (0.45 in), in contrast to the ISO standard.

Flatness of mounting surface has to be 0.01 mm (0.0004 in) over 100 mm (3.94 in), average surface finish R_a better than $0.8 \mu\text{m}$ (0.0000314 in).

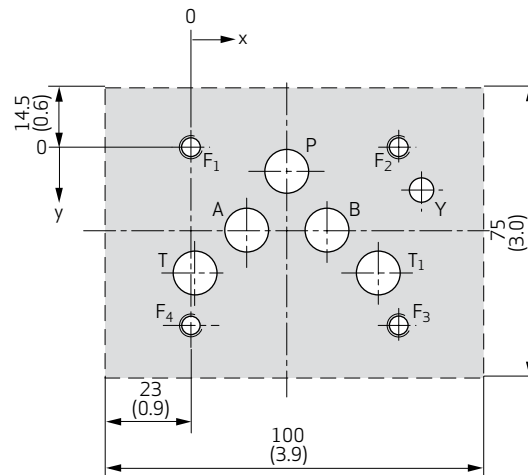

Designation	P	A	B	T	T_1	Y	F_1	F_2	F_3	F_4
Size \varnothing	11.5	11.5	11.5	11.5	11.5	6.3	M6	M6	M6	M6
mm	0.45	0.45	0.45	0.45	0.45	0.25	M6	M6	M6	M6
in										
Position x	27	16.7	37.3	3.2	50.8	62	0	54	54	0
mm	1.063	0.657	1.469	0.126	2	2.441	0	2.126	2.126	0
in										
Position y	6.3	21.4	21.4	32.5	32.5	11	0	0	46	46
mm	0.248	0.843	0.843	1.28	1.28	0.433	0	0	1.811	1.811
in										

ELECTRONICS

Pin Assignment for Valves with 6-pole + PE Connector, Pin Contacts (X1)

According to EN 175201-804, mating connector (type R or S, metal) with leading protective earth pin (⊕)

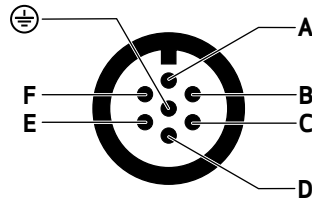

Pin	Pin assignment	Signal type ¹⁾	
		Voltage floating	Current floating ²⁾
A	Supply voltage	$U_{A-B} = 24 V_{DC}$ (18 to 32 V_{DC}) referenced to GND (reverse polarity protected against GND)	
B	GND	Power ground/signal ground	
C	Enable input	$U_{C-B} > 8.5$ to 32 V_{DC} referenced to GND: Valve ready for operation (enabled) $U_{C-B} < 6.5 V_{DC}$ referenced to GND: Valve disabled The input resistance is 10 k Ω	
D	Command signal - spool position	$U_{in} = U_{DE}$ $R_{in} = 20$ k Ω	$I_{in} = I_D = -I_E$ $R_{in} = 200 \Omega$ $I_{max} = \pm 25$ mA
E	Reference point Input rated command	Reference for pin D ³⁾	
F	Actual value - spool position	$U_{F-B} = 2$ to 10 V; U_{F-B} is proportional to the spool position; 6 V corresponds to the spool center position; $R_L = 500 \Omega$	$I_{out} = 4$ to 20 mA referenced to GND; I_{out} is proportional to the spool position; 12 mA corresponds to the spool center position; the output is short-circuit-proof; $R_L = 0$ to 500 Ω
⊕	Protective earth (PE)	Connected with valve body	

1) Signal ranges see next page.

2) Command signals $I_{in} < 3$ mA (due to cable break, for example) indicates a failure of 4 to 20 mA signals. The valve reaction to this failure may be customized and activated by the customer.

3) The potential difference between pins D or E referenced to pin B must be between -15 and +32 V.

ELECTRONICS

Ordering Codes and Signals for Valves with 6-pole + PE Connector (X1)

Ordering code position 10	Command signal ±100% spool position		Actual value ±100 % spool position	
D	$U_D - U_E$	-10 to +10 V	$U_F - U_B$	2 to 10 V
M	$U_D - U_E$	-10 to +10 V	I_F	4 to 20 mA
X	I_D	-10 to +10 mA	I_F	4 to 20 mA
E	I_D	4 to 20 mA	I_F	4 to 20 mA

Note: See inside back cover for complete ordering information.

Command Signal Current Floating, Ordering Code X or E

The spool position is proportional to $I_D = -I_E$.
 For a command signal $I_D = 20$ mA (code E) or +10 mA (code X) the spool moves to 100 % P → A and B → T.
 For a command signal $I_D = 12$ mA (code E) or 0 mA (code X) the spool is in the defined center position.

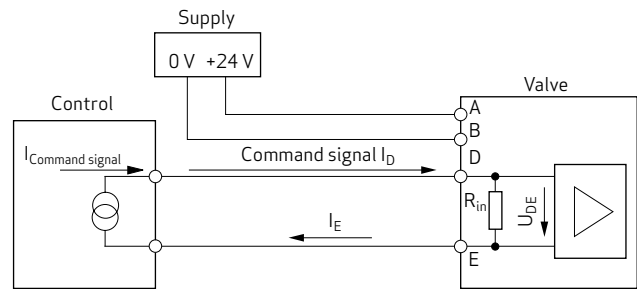

Command Signal Voltage Floating, Ordering Code D or M

The spool position is proportional to $U_D - U_E$.
 For a command signal $U_D - U_E = +10$ V the spool moves to 100 % P → A and B → T.
 For a command signal $U_D - U_E = 0$ V the spool is in the defined center position.

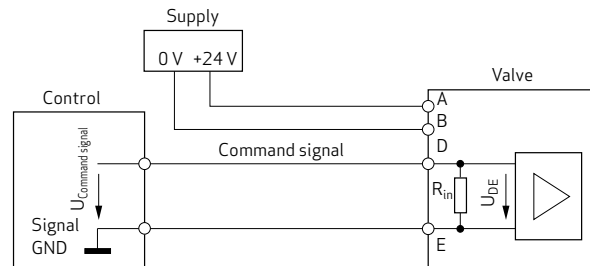

Actual Value 4 to 20 mA, Ordering Code M, X or E

The signal can be used for monitoring and fault detection purposes. The spool position is proportional to I_{out} .
 The spool position corresponds to 4 to 20 mA. At 12 mA the spool is in center position.
 20 mA corresponds to 100 % valve opening P → A and B → T. A cable fault is detected by $I_{out} = 0$ mA.
 Actual value $U_{out} = 2$ to 10 V with resistor $R_L = 500 \Omega$ (0.25 W) provided by customer.

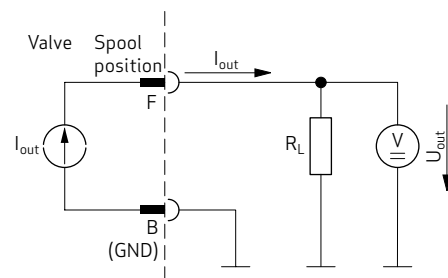

Actual Value 2 to 10 V, Ordering Code D

The signal can be used for monitoring and fault detection purposes. The spool position is proportional to U_{out} .
 The spool position corresponds to 2 to 10 V. At 6 V the spool is in center position.
 10 V corresponds to 100 % valve opening P → A and B → T. A cable fault is detected by $U_{out} = 0$ V.
 $R_L = 500 \Omega$ (0.25 W).

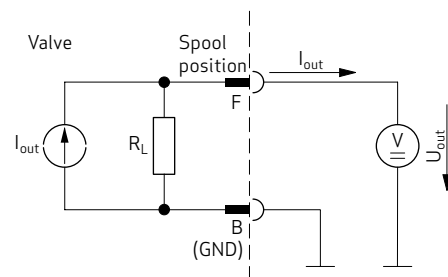

Note: For more information see Technical Notes TN 353 "Protective Grounding and Electrical Shielding of Valves", TN 426 "Wiring Instructions" and TN 494 "Maximum Permissible Length of Electric Cables for Valves with Integrated Electronics".
 Visit www.moog.com to download document.

ELECTRONICS

Pin Assignment for Valves with 11-pole + PE Connector, Pin Contacts (X1)

According to EN 175201-804, mating connector (type E, metal) with leading protective earth pin (⊕)

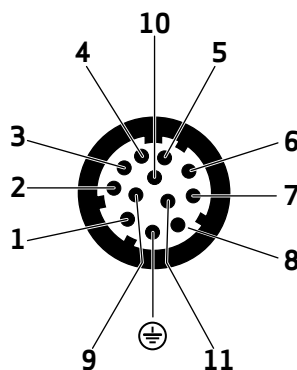

Pin	Pin assignment	Signal type ¹⁾	
		Voltage floating	Current floating ²⁾
1	Not used		
2			
3	Enable input	$U_{3-10} > 8.5$ to $32 V_{DC}$ referenced to GND: Valve ready for operation (enabled) $U_{3-10} < 6.5 V_{DC}$ referenced to GND: Valve disabled The input resistance is $10 k\Omega$	
4	Command signal - spool position	$U_{in} = U_{4-5}$ $R_{in} = 20 k\Omega$	$I_{in} = I_4 = -I_5$ $R_{in} = 200 \Omega$ $I_{max} = \pm 25 mA$
5	Reference point Input rated command	Reference for pin 4 ³⁾	
6	Actual value - spool position	U_{6-10} : 2 to 10 V referenced to GND (U_{out} is proportional to the spool position, 6 V corresponds to the valve middle position, the output is short-circuit-proof); $R_L = 500 \Omega$	I_{out} : 4 to 20 mA referenced to GND (I_{out} is proportional to the spool position, 12 mA corresponds to the valve middle position, the output is short-circuit-proof); $R_L = 0$ to 500Ω
7	Not used		
8	Digital output - valve status	$U_{8-10} > 8.5 V$: Valve ready for operation (enabled and supply OK). $U_{8-10} < 6.5 V$: Valve disabled. Load type: Ohmic, inductive, lamp load. $I_{max} = 1.5 A$ (short-circuit-proof).	
9	Supply voltage	$U_{9-10} = 24 V_{DC}$ (18 to $32 V_{DC}$) referenced to GND (reverse polarity protected against GND)	
10	GND	Power ground/signal ground (enable and output)	
11	Digital output - error monitoring	$U_{11-10} > 8.5 V$: No error. $U_{11-10} < 6.5 V$: Indicates error ⁵⁾ . Load type: Ohmic, inductive, lamp load. $I_{max} = 1.5 A$ (short-circuit-proof ⁴⁾).	
⊕	Protective earth (PE)	Connected with valve body	

1) Signal ranges see next page.

2) Command signals $I_{in} < 3 mA$ (due to cable break, for example) indicates a failure of 4 to 20 mA signals. The valve reaction to this failure may be customized and activated by the customer.

3) The potential difference between pins 4 or 5 referenced to pin 10 must be between -15 and +32 V.

4) The currents drawn at the outputs pin 8 and 11 (referenced to GND) must be added to the valve supply current. The valve fuse must be configured for the total current.

5) Output can be programmed at the factory, enable function ordering code: K and L - safe position of spool, M and R - command signal/ actual valve deviation, others upon request. See position 13 on the inside back cover for complete ordering information.

ELECTRONICS

Ordering Codes and Signals for Valves with 11-pole + PE Connector (X1)

Ordering code position 10	Command signal ±100% spool position		Actual value ±100 % spool position	
D	$U_4 - U_5$	-10 to +10 V	$U_6 - U_{10}$	2 to 10 V
M	$U_4 - U_5$	-10 to +10 V	I_6	4 to 20 mA
X	I_4	-10 to +10 mA	I_6	4 to 20 mA
E	I_4	4 to 20 mA	I_6	4 to 20 mA

Note: See inside back cover for complete ordering information.

Command Signal Current Floating, Ordering Code X or E

The spool position is proportional to $I_4 - I_5$.
 For a command signal $I_4 = 20$ mA (code E) or +10 mA (code X) the spool moves 100 % P → A and B → T.
 For a command signal $I_4 = 12$ mA (code E) or 0 mA (code X) the spool is in the defined center position.

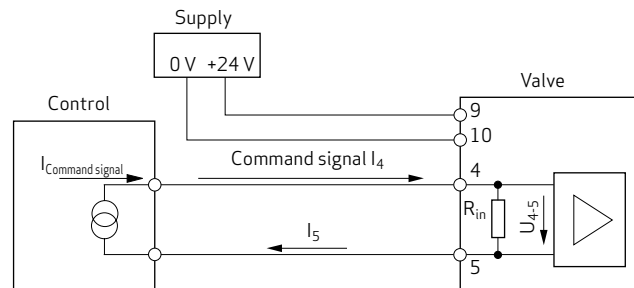

Command Signal Voltage Floating, Ordering Code M or D

The spool position is proportional to $U_4 - U_5$.
 For a command signal $U_4 - U_5 = +10$ V the spool moves 100 % P → A and B → T.
 For a command signal $U_4 - U_5 = 0$ V the spool is in the defined center position.

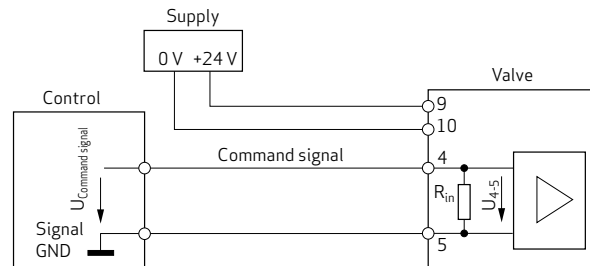

Actual Value 4 to 20 mA, Ordering Code M, X or E

The actual value, that is the position of the spool when using the flow function, is taken at pin 6 (11-pole + PE connector), respectively (wiring diagram below). These signals can be used for monitoring and fault detection purposes. The full spool stroke corresponds to 4 to 20 mA. At 12 mA command the spool is in center position. 20 mA corresponds to 100 % valve opening P → A and B → T. Using the actual value signal 4 to 20 mA a cable fault is detected by $I_{out} = 0$ mA.
 Actual value $I_{out} = 4$ to 20 mA
 Actual value $U_{out} = 2$ to 10 V with resistor $R_L = 500 \Omega$ (0.25 W) provided by customer

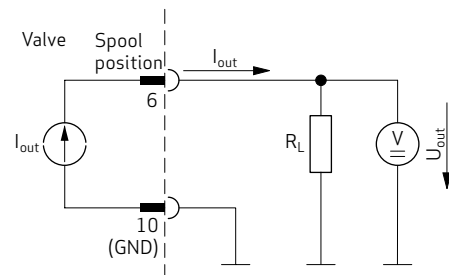

Actual Value 2 to 10 V, Ordering Code D

The signal can be used for monitoring and fault detection purposes. The spool position is proportional to U_{out} . The spool position corresponds to 2 to 10 V. At 6 V the spool is in center position. 10 V corresponds to 100 % valve opening P → A and B → T. A cable fault is detected by $U_{out} = 0$ V.
 $R_L = 500 \Omega$ (0.25 W).

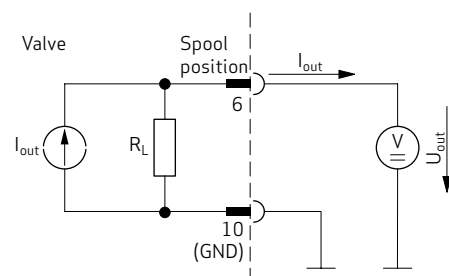

Note: For more information see Technical Notes TN 353 "Protective Grounding and Electrical Shielding of Valves", TN 426 "Wiring Instructions" and TN 494 "Maximum Permissible Length of Electric Cables for Valves with Integrated Electronics". Visit www.moog.com to download document.

ELECTRONICS

Installation Drawings Electronic Housing

Installation Drawing for Valves with Analog Activation

Ordering code¹⁾ O: Without fieldbus connector

- X1 Valve connector
- X10 Service connector

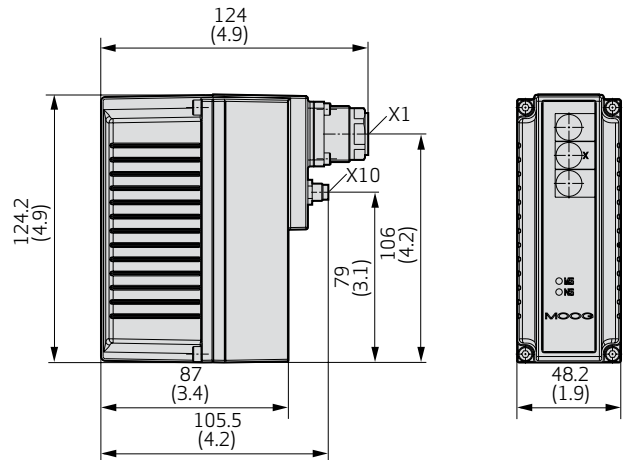

Installation Drawing for Valves with CANopen Fieldbus Connector

Ordering code¹⁾ C: CANopen

- X1 Valve connector
- X3 Fieldbus connector
- X4 Fieldbus connector

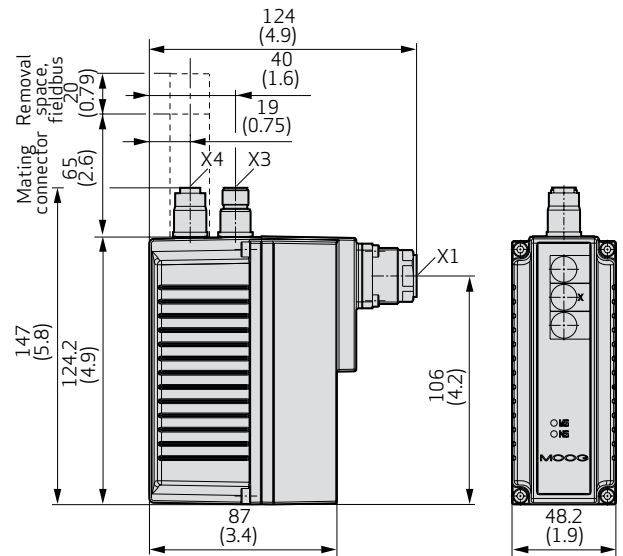

Installation Drawings for Valves with EtherCAT or PROFIBUS-DP Fieldbus Connector

Ordering code¹⁾ E: EtherCAT
Ordering code D: PROFIBUS-DP

- X1 Valve connector
- X3 Fieldbus connector
- X4 Fieldbus connector
- X10 Service connector

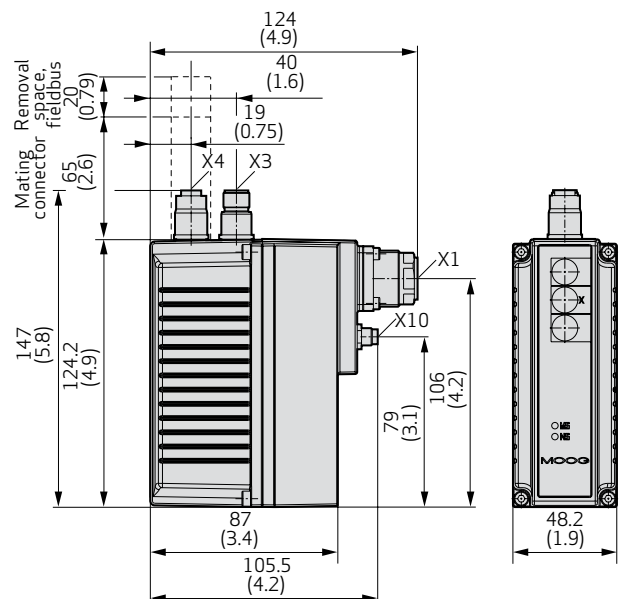

1) See position 14 on the inside back cover for complete ordering information.

ELECTRONICS

Fieldbus Connectors

CANopen Connectors (X3, X4)

- Ordering Code¹⁾ C: CANopen
- Coding A
- Thread M12x1
- 5-pole

Pin	Signal X3, X4	Description
1	CAN_SHLD	Shield
2	CAN_V+	Not connected in the valve
3	CAN_GND	Ground
4	CAN_H	Transceiver H
5	CAN_L	Transceiver L

External thread, pin contacts

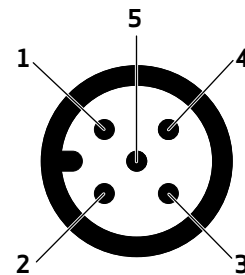

View on CAN connector X3

Internal thread, socket contacts

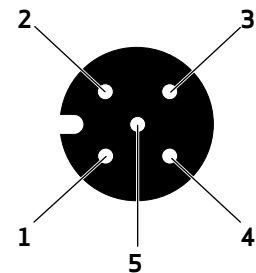

View on CAN connector X4

EtherCAT IN/OUT Connectors (X3, X4)

- Ordering Code¹⁾ E: EtherCAT
- Coding D
- Thread M12x1
- 4-pole

Pin	Signal X4 IN	Signal X3 OUT	Description
1	TX + IN	TX + OUT	Transmit
2	RX + IN	RX + OUT	Receive
3	TX - IN	TX - OUT	Transmit
4	RX - IN	RX - OUT	Receive

Internal thread, socket contacts

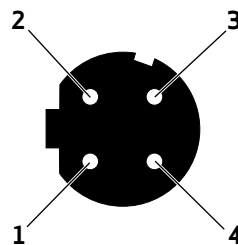

View on EtherCAT connector X3

Internal thread, socket contacts

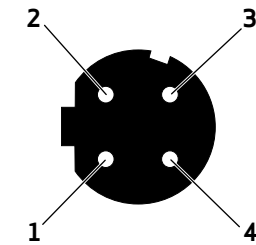

View on EtherCAT connector X4

PROFIBUS-DP Connectors (X3, X4)

- Ordering Code¹⁾ D: PROFIBUS-DP
- Coding B
- Thread M12x1
- 5-pole

Pin	Signal X3, X4	Description
1	Profi V+	Power supply 5 V of terminal resistors
2	Profi A	Receive/transmit data -
3	Profi GND	Ground
4	Profi B	Receive/transmit data +
5	Shield	Shield

External thread, pin contacts

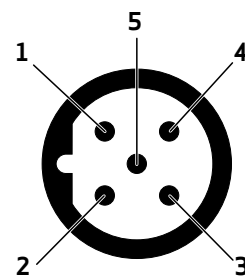

View on PROFIBUS-DP connector X3

Internal thread, socket contacts

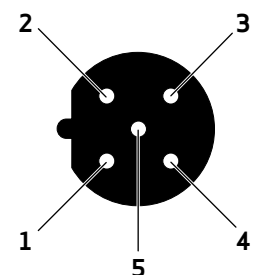

View on PROFIBUS-DP connector X4

1) See inside back cover for complete ordering information.

FLOW CALCULATION

When the valve is open, the prevailing flow is dependent not only on the spool position, (i.e. the opening cross section of the valve), but also on the pressure drop at the individual lands. When the valve is deflected at 100 %, it delivers the rated flow with the rated pressure drop.

The rated flow of a proportional valve corresponds to a pressure drop of 5 bar (75 psi) per land, equating to 10 bar (145 psi) for two lands. When a valve is opened at 100 %, the flow can be calculated as a function of the actual pressure drop with the aid of the formula or taken from the diagram.

$$Q = Q_N \cdot \sqrt{\frac{\Delta p}{\Delta p_N}}$$

- Q [l/min (gpm)] actual flow
- Q_N [l/min (gpm)] rated flow
- Δp [bar (psi)] actual pressure drop per spool land
- Δp_N [bar (psi)] rated pressure drop per spool land

Flow chart

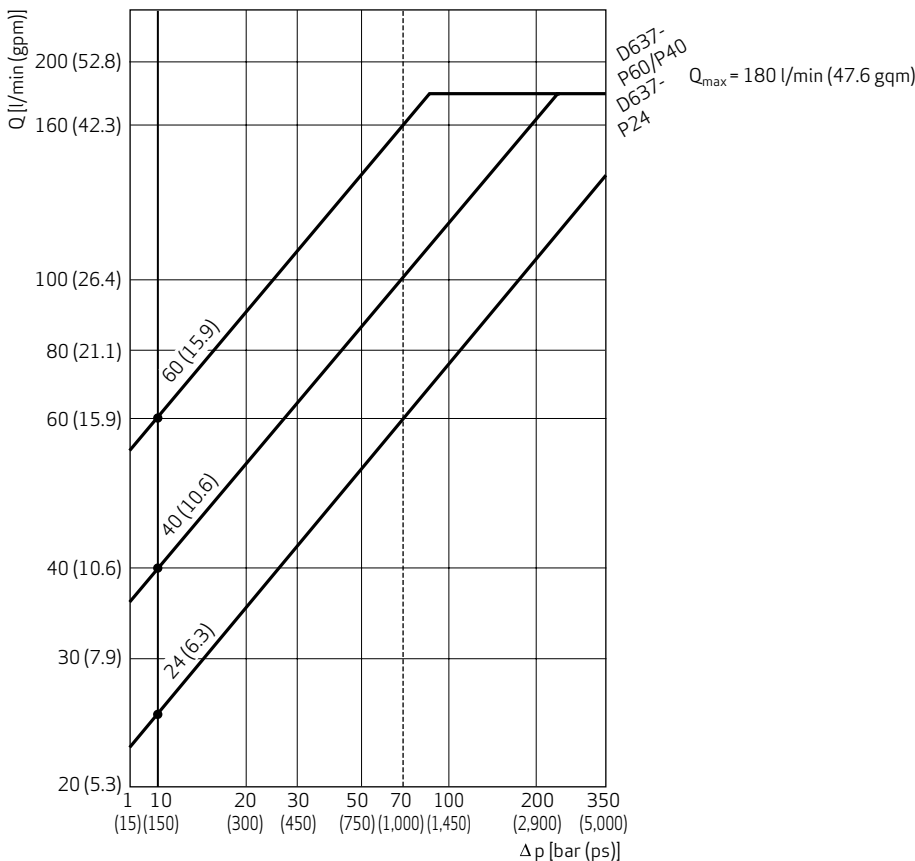

The actual flow in the valve ports must not exceed a mean flow velocity of approximately 30 m/s (96.5 ft/s) due to the risk of cavitation.

When operating the valves close to these application limits, it is necessary to drill the ports to the maximum possible diameters (see specifications for the respective valve).

For ISO 4401 size 05 mounting surfaces the second tank port must additionally be connected starting from a flow Q exceeding 60 l/min (15.9 gpm).

ELECTRONICS

Digital Valve Electronics

The valve electronics is based on microprocessor hardware with corresponding A/D-D/A converters for analog input and output signals. All functions of the valve are integrated in the firmware. The digital electronics offer the following advantages over conventional analog electronics:

- Greater flexibility: Ability to change the valve parameters easily using configuration software and the possibility of linearizing flow curves
- Higher reliability due to integrated monitoring functions
- Easier maintenance due to diagnostic capability and recording the fault history
- Remote maintenance and setup

In the basic version the valve has a standard connector, and service connector and does not include the fieldbus interface. In this case the valve is actuated via an analog command signal.

The service connector offers the possibility to connect the valve to a PC or Notebook via an USB-to-CAN adaptor (see accessories). Its CANopen interface offers access to the valve parameters, which can be changed and monitored, as well as diagnosing valve performance and possible faults.

The flexibility of the integrated firmware enables the user to optimize the valve characteristic on-site as required by the application:

- Adapting the valve flow curve to the needs of the controlled system
- Adjusting the maximum valve opening separately for each direction of motion
- Defining fault reactions

The results obtained by the parameter changes can be viewed and analyzed directly using the built-in data logger. The parameters optimized during commissioning can be saved and copied. When the valve is replaced or used for series applications no tuning is required. The valves are supplied with a predefined parameter set if required.

Optional Fieldbus Interface

When the valves are operated with a fieldbus, they are parameterized, activated and monitored via the fieldbus. CANopen, PROFIBUS-DP or EtherCAT interfaces are available. Other fieldbus communication protocols are available upon request. The fieldbus interface is equipped with two bus connectors (IN/OUT) for cost-effective wiring. Valves can be integrated directly into the bus without any external T-joints. The electrically isolated fieldbus interface ensures reliable data transfer. Data from additional analog inputs or from SSI and encoders can be transmitted via fieldbus (inputs available upon request).

FIELDBUS INTERFACE

Modern automation technology is characterized by an increasing decentralization of processing functions via serial data communication systems. The use of serial bus systems in place of analog signal transfer guarantees greater system flexibility with regard to alterations and expansions.

There is also considerable potential for saving project planning and installation costs in many areas of industrial automation. Further possibilities of parameterization, better diagnostics and a reduction of the number of variants are advantages which have only been made possible by the use of field buses.

VDMA Profile Fluid Power Technology

In a working group within the VDMA (German Machinery and Plant Manufacturers' Association), a device profile was created in collaboration with numerous well-known hydraulic system manufacturers. This profile describes the communication between hydraulic components via a fieldbus and defines uniform functions and parameters. In this way, a standardized exchange format covering all manufacturers was created.

DCVs and ACVs can be equipped with the following fieldbus interfaces: CANopen, PROFIBUS-DP or EtherCAT.

CANopen

According to ISO 11898, IEC/EN 61800-7 CAN bus was originally developed for use in automobiles, but has also been used for years in a variety of industrial applications. The CAN bus is primarily designed for transmission reliability and speed.

The CAN bus has the following general features:

- Multi-master system: Each node can transmit and receive
- Topology: Line structure with short stub cables
- Network expansion and transmission rates:
 - Up to 25 m (80.4 ft) at 1 Mbit/s
 - Up to 5,000 m (16,090 ft) at 25 kbit/s
- Addressing type: Message-orientated via identifiers. Priority assignment of messages possible via identifiers
- Safety: Hamming distance=6, i.e. up to 6 individual errors per message are detected
- CiA408: Device profile fluid power technology for proportional valves and hydrostatic transmissions
- Other used CiA specifications: CiA102, CiA301, CiA303, CiA305 and CiA306
- Bus physics: ISO 11898
- Maximum number of nodes: 127

PROFIBUS-DP

According to EN 61158, PROFIBUS-DP was developed for process and manufacturing industries. It is thereby supported by numerous control system manufacturers.

PROFIBUS-DP has the following features:

- Multi-master system: The masters share access time and initiate communication. The slaves react only upon request
- Topology: Line structure with short stub cables
- Network expansion and transmission rates:
 - Up to 100 m (321.8 ft) at 12 Mbit/s
 - Up to 1,200 m (3,861.6 ft) at 9,6 kbit/s per segment
- Use of repeaters possible
- Addressing type: Address-orientated. Priority/cycle time assignment of messages via master configuration
- Bus physics: EIA-485
- Maximum number of nodes: 126

EtherCAT

According to IEC 61800-7 EtherCAT was developed as an industry bus based on Ethernet to meet the increasing demands for faster cycle times. The EtherCAT bus is designed for high data transmission rates and fast cycle times.

The EtherCAT bus has the following features:

- Single-master system: The master initiates communication. The slaves react only upon request
- Topology: Line, star, tree and ring structure based on the daisy chain principle
- Network expansion and transmission rates: 100 m (321.8 ft) between two nodes at 100 Mbit/s
- Addressing type: Address-orientated, one telegram for all nodes
- Bus physics: Fast Ethernet 100 Base Tx
- Maximum number of nodes: 65,535

CONFIGURATION SOFTWARE

The Moog Valve and Pump Configuration Software is a Microsoft Windows based software to configure the digital Moog Valves and Pumps (DCV/ACV/RKP-D).

It enables a user to control and exchange data between a PC and a Moog Digital Control Valve, Axis Control Valve as well as Moog Radial Piston Pumps with Digital Control. System parameters can be set, monitored, recorded and visualized with a flexible graphical user interface.

System Requirements

- PC/notebook with Windows 7/8.1/10
- Internet Explorer 9
- 1 GB RAM
- 1 GB free hard disk space
- Monitor resolution 1024 x 768 pixels
- Keyboard, mouse
- To connect the software with a device, the following additional equipment is required:
 - A free USB port at service PC
 - USB-TO-CAN-adapter with driver
Interface card IXXAT USB-to-CAN compact recommended (order code C43094-001)
 - CAN-cable
CAN-cable (Sub-D9 to M12 with termination resistor) recommended (order code TD3999-137), optional M8 to M12, A-coded adapter (order code CA40934-001)
- See http://www.moog.com/literature/ICD/Moog-ServoValves-DCV_Getting_Started-Manual-en.pdf chapter 9.1 "Requirements".

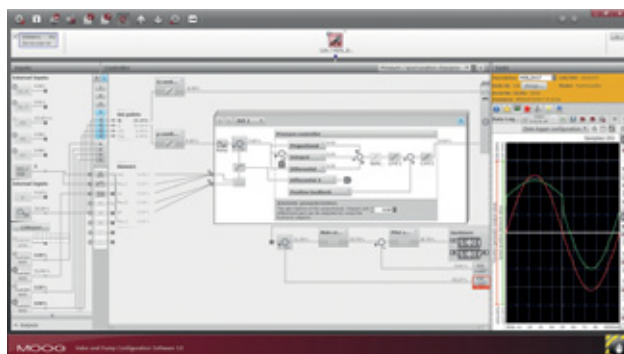

Download

This software is provided by Moog at no charge on the download page: <http://www.moogsoftwaredownload.com/> (see "Digital Valves and Pumps").



ACCESSORIES AND SPARE PARTS

Series-specific Accessories and Spare Parts

Spare Parts Size 05 - D637 Proportional Valve

Part name	Description	Material	Part number
Service sealing set	Contains the following O-rings: <ul style="list-style-type: none"> 5 pieces for ports P, T, T₁, A, B, inner Ø 12.4 mm (0.49 in) x Ø 1.8 mm (0.07 in) 2 pieces for ports X, Y, inner Ø 15.6 mm (0.61 in) x Ø 1.8 mm (0.07 in) 	FKM 90 Shore	B97215-V681-10
		HNBR 90 Shore	B97215-H681-10

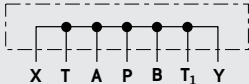
Accessories Size 05 - D637 Proportional Valve

Part name	Description	Remark	Part number
Flushing plate	P-A-B-T-T ₁ -X-Y Mounting screws and O-rings included		B67728-001
	P-T-T ₁ and X-Y Mounting screws and O-rings included		B67728-003
	P-T-T ₁ -X-Y Mounting screws and O-rings included		B67728-002
Manifold	ISO 4401 size 05, ports P, A, B, T with G 3/4 A, ports X, Y with G 1/4 A		A88903-001
Mounting screws	4 pieces M6x40, ISO 4762-10.9, tightening torque 11 Nm (97 lbf in)		A03665-060-040
Shipping plate	ISO 4401 size 05		A40508

Documents Size 05 - D637 Proportional Valve

Part name	Description	Document number
Mounting and Installation Notes	D636, D637, D638 and D639 Series Digital Control Servo Valves	B97072-636
Technical Note	Protective Grounding and Electrical Shielding of Hydraulic Valves with Integrated Electronics	TN 353
	Wiring Instruction	TN 426
	Maximum Permissible Length of Electric Cables for Valves with Integrated Electronics	TN 494
User Manual	Electrical Interfaces	CA63420
	ATEX and IECEx - D637K and D639K Series Digital Control Servo Valves	CDS29577
	Digital Control Valves with EtherCAT Interface	CDS33722
	Digital Control Valves with CANopen Interface	CDS33853
	Digital Control Valves with PROFIBUS Interface	CDS33854
	Getting Started Digital Control Valves	CDS45379
	Axis Control Valves with CANopen Interface	CDS45934
	Axis Control Valves with EtherCAT Interface	CDS45935
Axis Control Valves with PROFIBUS Interface	CDS45936	

Note: Visit www.moog.com to download a document using the document number in a search.

ACCESSORIES AND SPARE PARTS

Series-independent Accessories

Accessories D637 Proportional Valves

Part name	Description	Remark	Part number
Dust protection cap for fieldbus connectors X3, X4	For external thread M12x1, metal	Required for operation without mating connector (IP protection)	C55823-001
	For internal thread M12x1, metal		CA24141-001
Dust protection cap for service connector X10	For internal thread M8x1, plastics		CA23105-080-010
Mains power connection	Power supply 24 V _{DC} , 10 A, SELV		D137-003-001
	Power supply cable, length 2 m (6.4 ft)		B95924-002
Mating connector	Cable with straight mating connector 11-pole + PE	3, 5, 10, 15, 20 or 25 m, e.g. for 5 m specify 005, other length upon request	C21031-xxx-001
	Cable with straight mating connector 6-pole + PE		C21033-xxx-001
	Mating connector, elbow 6-pole + PE	In accordance with EN 175201-804, type S, metal, IP65, crimp contact Ø 0.75 to 1.5 mm ² (0.0012 to 0.0023 in ²), conus Ø 12.2 mm (0.48 in), cable Ø 8 to 12 mm (0.31 to 0.47 in), sealing element Ø 9 to 13 mm (0.35 to 0.51 in)	B97069-061
	Mating connector, straight 11-pole + PE	In accordance with EN 175201-804, type R, metal, IP65, crimp contact Ø 0.14 to 0.5 mm ² (0.00022 to 0.00078 in ²), cable Ø 12 to 15 mm (0.47 to 0.59 in)	B97067-111
	Mating connector, straight 6-pole + PE	In accordance with EN 175201-804, type R, metal, IP65, crimp contact Ø 0.75 to 1.5 mm ² (0.0012 to 0.0023 in ²), conus Ø 12.2 mm (0.48 in), cable Ø 8 to 12 mm (0.31 to 0.47 in), sealing element Ø 9 to 13 mm (0.35 to 0.51 in)	B97007-061
Service and commissioning set	Adapter for service connector X10, M8x1 to M12x1		CA40934-001
	Configuration/commissioning cable 2 m (6.4 ft), M12x1 to EIA-232, other length upon request		TD3999-137
	USB to CAN adapter (IXXAT)		C43094-001
Service and commissioning software	Moog Valve and Pump Configuration Software	Download software free of charge at www.moogsoftwaredownload.com	

ACCESSORIES AND SPARE PARTS

Accessories - Installation Drawings

Mating Connector, Straight 6-pole + PE

In accordance with EN 175201-804, type R, metal, IP65, crimp contact $\varnothing 0.75$ to 1.5 mm^2 (0.0012 to 0.0023 in^2), conus $\varnothing 12.2 \text{ mm}$ (0.48 in), cable $\varnothing 8$ to 12 mm (0.31 to 0.47 in), sealing element $\varnothing 9$ to 13 mm (0.35 to 0.51 in)

Part number B97007-061

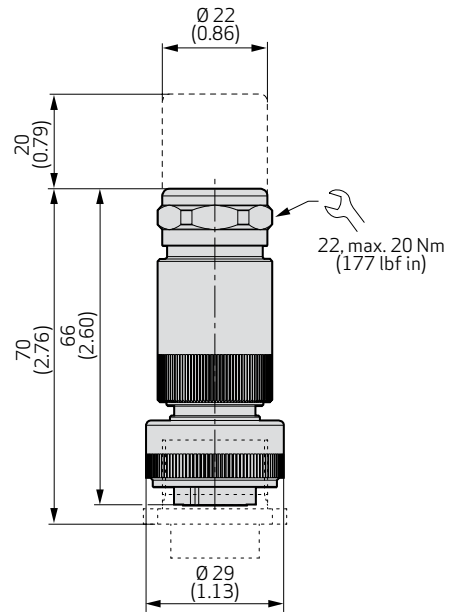

Mating Connector, Elbow 6-pole + PE

In accordance with EN 175201-804, type S, metal, IP65, crimp contact $\varnothing 0.75$ to 1.5 mm^2 (0.0012 to 0.0023 in^2), conus $\varnothing 12.2 \text{ mm}$ (0.48 in), cable $\varnothing 8$ to 12 mm (0.31 to 0.47 in), sealing element $\varnothing 9$ to 13 mm (0.35 to 0.51 in)

Part number B97069-061

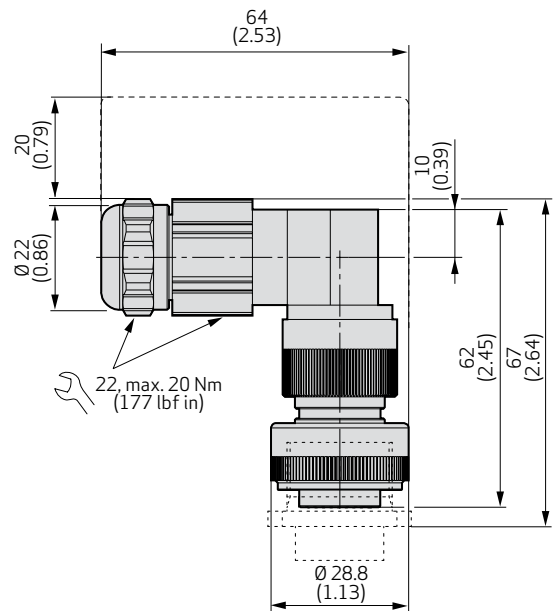

ACCESSORIES AND SPARE PARTS

Accessories - Installation Drawings

Mating Connector, Straight 11-pole + PE

In accordance with EN 175201-804, type R, metal, IP65, crimp contact \varnothing 0.14 to 0.5 mm² (0.00022 to 0.00078 in²), cable \varnothing 12 to 15 mm (0.47 to 0.59 in)

Part number B97067-111

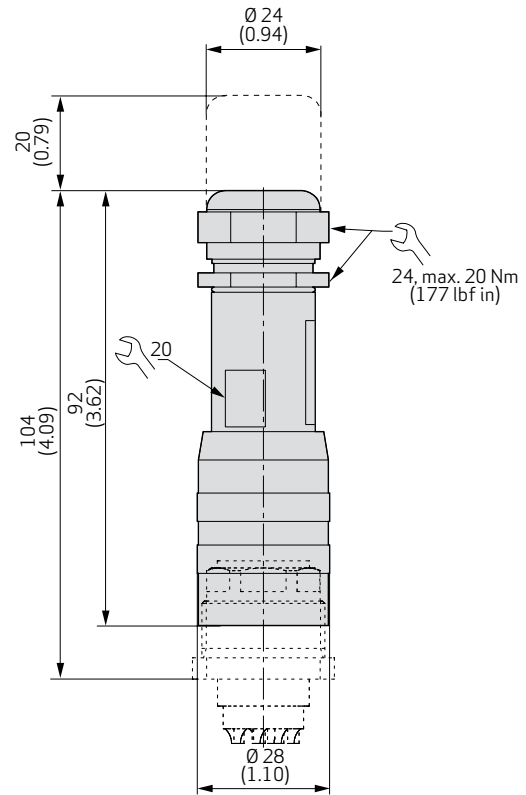

ABOUT MOOG

Moog Inc. is a worldwide designer, manufacturer and integrator of precision control components and systems. Moog's Industrial Group designs and manufactures high performance motion control solutions combining electric, hydraulic, and hybrid technologies with expert consultative support in a range of applications including energy production and generation machinery, industrial production machinery and simulation and test equipment. We help performance-driven companies design and develop their next-generation machines.

This vast scope ensures that our engineers remain close to the needs of machine builders and provide flexible design solutions and technical expertise tailored to our customers' toughest challenges.

Moog experts work in close collaboration with machine builders and application engineers to design motion control systems for greater productivity, higher reliability, superior connectivity, less costly maintenance and more effective operations. Our regional presence, industry knowledge and design flexibility ensures Moog motion control solutions are tailored to their environment — from meeting operating regulations and performance standards, to taking machine performance to a higher level.

Products

At the heart of every Moog solution is an array of products engineered for precision, high performance and reliability. For more than six decades, Moog products have been specified for critical machine applications.

Some are developed specifically for unique operating environments. Others are standard equipment on machines across many industries. All are continuously improved to take advantage of the latest technology breakthroughs and advancements.

Moog products include:

- Servo and Proportional Valves
- Industrial Cartridge Valves
- Integrated Hydraulic Manifold Systems
- Radial Piston Pumps
- Servo Motors and Servo Drives
- Machine and Motion Controllers
- Electro-Mechanical Actuators
- Ball, Planetary Roller and Inverted Roller Screws



Servo Valves

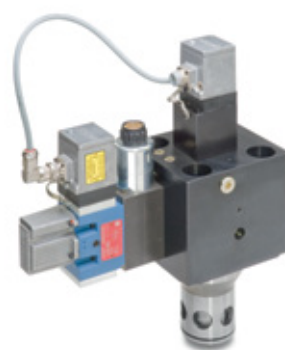

Servo Cartridge Valves



Radial Piston Pumps



Servo Drives

SOLUTIONS

Solutions

Hydraulic Solutions

Since Bill Moog invented the first commercially viable servo valve in 1951, Moog has set the standard for world-class hydraulic technology. Today, Moog products are used in a variety of applications - providing high power, enhanced productivity and ever better performance for some of the worlds most demanding applications.

Electric Solutions

Clean operation, low noise generation, less maintenance and reduced power consumption make Moog electric solutions ideal for applications worldwide. Moog is the ideal partner for applications where transitioning technologies requires special expertise.

Hybrid Solutions

By incorporating the advantages of existing hydraulic and electric technologies - including modular flexibility, increased efficiency and cleanliness - into innovative hybrid solutions, Moog offers new performance potential in specialized applications.



Flight Simulation



Simulation Table

MOOG GLOBAL SUPPORT

Moog Global Support is our promise to help you:

- Maximize uptime
- Get more from your machine investment

It reflects our commitment to keeping your motion control components and systems running at peak performance. We help you transform maintenance by moving from reactive to planned. Around the globe in 24 countries, local teams of trained Moog technicians are on standby with the services you need from express repairs to exchange programs, and on-site technical support.

This promise offers many benefits to our customers including:

- Reduce your downtime by keeping critical machines running in peak performance
- Protect your investment by ensuring reliability, versatility and long-life of products
- Better plan your maintenance activities and make systematic upgrades
- Leverage our flexible programs to meet the unique service requirements of your facility

Look to Moog for global support including:

- **Factory Repair Services** – Restore your products to “like new” performance with high quality repairs using authentic OEM components
- **Replacement Parts/Spares** – Obtain authentic OEM products whenever and wherever they are needed around the globe
- **Professional Field Services** – Access on-site technical support from knowledgeable professionals for installation, commissioning and troubleshooting
- **Flexible Service Agreements** – Lower your total cost of ownership and reduce your risk of downtime with a tailored package of services to meet your needs
- Offer consistent quality anywhere in the world

For more information on Moog Global Support visit www.moogglobalsupport.com.



NOTES

NOTES

ORDERING CODE

Model number (assigned at the factory)

D 637

Type designation

1 2 3 4 5 6 7 8 9 10

P K 6

Model designation

Variant

1 Valve type

P Proportional valve with integrated digital electronics

2 D637: Rated flow per spool land [l/min (gpm)]

	For $\Delta p_N = 5$ bar (75 psi)	For $\Delta p_N = 35$ bar (500 psi)
24	24 (6.3)	60 (15.9)
40	40 (10.6)	100 (26.4)
60	60 (15.9)	160 (42.3)

3 Pressure range [bar (psi)]

Maximum operating pressure
K 350 (5,000)

4 Spool design

A 4-way: 1.5 to 3 % positive overlap, linear flow characteristic
D 4-way: 10 % positive overlap, linear flow characteristic
J 4-way: 1.5 to 3 % positive overlap, A : B = 2 : 1, linear flow characteristic
Z 2x2-way: P → A, B → T, only with port Y
 Special spool upon request

5 Linear force motor

6 Standard

Series

D637

6 Spool position without electrical supply

M Center position
F P → B, A → T connected (approximately 10 % open)
D P → A, B → T connected (approximately 10 % open)

7 Y port

0 Closed with screw plug $p_{Tmax} = 50$ bar (725 psi)
3 Open with filter element $p_T > 50$ bar (725 psi)

8 Seal material

H HNBR
V FKM
 Further upon request

9 Valve connector X1

S 6-pole + PE EN 175201-804
E 11-pole + PE EN 175201-804

10 Signals for flow Q

	Command signal Q	Actual value spool position
D	± 10 V	2 to 10 V
M	± 10 V	4 to 20 mA
X	± 10 mA	4 to 20 mA
E	4 to 20 mA	4 to 20 mA
9	Fieldbus ¹⁾	Fieldbus ¹⁾
	Further upon request	

1) Only in conjunction with fieldbus connector "C, D, E" (changeover to analog signals "M, X, E" possible)

ORDERING CODE

11	12	13	14	15	16
...	2	-			A1
16 Device capability					
A1 Q control					
15 Service connector X10					
O1 Without ⁶⁾					
K1 With ⁵⁾					
14 Fieldbus connector X3, X4					
C CANopen					
D PROFIBUS-DP ⁴⁾					
E EtherCAT ⁴⁾					
O Without fieldbus connector ⁴⁾					
13 Enable function					
A	B	K	L	M	R
X	-	X	-	X	-
If the enable signal is low: The spool moves to a closed loop controlled neutral position (the HOLD position)					
-	X	-	X	-	X
If the enable signal is low: The linear force motor is de-energized. The spool moves to its spring centered position (as defined at position 6 of the order code).					
-	-	X	X	-	-
Monitoring of the safe position of the spool at pin 11 ³⁾ . The range of the safe position can be freely defined (the default range is around the spring centered position). HIGH: Within the safe position range LOW: Outside the safe position range					
-	-	-	-	X	X
Monitoring of the spool control error at pin 11 ³⁾ . The threshold for the spool control error can be freely defined (the default value is <30 % of maximum spool stroke after 500 ms). HIGH: Control error is below the threshold LOW: Control error is above the threshold					
12 Valve function					
-					
11 Supply voltage					
2 24 V _{DC} , for more information, see section "Electronics"					

3) Only in combination with valve connector X1 "E"

4) Valve parameterization with commissioning software "Moog Valve and Pump Configuration Software" using M8 service connector

5) Only in conjunction with fieldbus connector "D, E, O"

6) Only in conjunction with fieldbus connector "C"

MORE PRODUCTS. MORE SUPPORT.

Moog designs a range of motion control products to complement those featured in this document. Moog also provides service and support for all of our products. For more information, contact the Moog facility closest to you.

Australia
+61 3 9561 6044
Service + 61 3 8545 2140
info.australia@moog.com
service.australia@moog.com

Brazil
+55 11 3572 0400
info.brazil@moog.com
service.brazil@moog.com

Canada
+1 716 652 2000
info.canada@moog.com

China
+86 21 2893 1600
Service +86 21 2893 1626
info.china@moog.com
service.china@moog.com

France
+33 1 4560 7000
Service +33 1 4560 7015
info.france@moog.com
service.france@moog.com

Germany
+49 7031 622 0
Service +49 7031 622 197
info.germany@moog.com
service.germany@moog.com

Hong Kong
+852 2 635 3200
info.hongkong@moog.com

India
+91 80 4057 6666
Service +91 80 4057 6604
info.india@moog.com
service.india@moog.com

Ireland
+353 21 451 9000
info.ireland@moog.com

Italy
+39 0332 421 111
Service 800 815 692
info.italy@moog.com
service.italy@moog.com

Japan
+81 46 355 3767
info.japan@moog.com
service.japan@moog.com

Korea
+82 31 764 6711
info.korea@moog.com
service.korea@moog.com

Luxembourg
+352 40 46 401
info.luxembourg@moog.com

The Netherlands
+31 252 462 000
info.thenetherlands@moog.com
service.netherlands@moog.com

Russia
+7 8 31 713 1811
Service +7 8 31 764 5540
info.russia@moog.com
service.russia@moog.com

Singapore
+65 677 36238
Service +65 651 37889
info.singapore@moog.com
service.singapore@moog.com

South Africa
+27 12 653 6768
info.southafrica@moog.com

Spain
+34 902 133 240
info.spain@moog.com

Sweden
+46 31 680 060
info.sweden@moog.com

Turkey
+90 216 663 6020
info.turkey@moog.com

United Kingdom
+44 (0) 1684 858000
Service +44 (0) 1684 278369
info.uk@moog.com
service.uk@moog.com

USA
+1 716 652 2000
info.usa@moog.com
service.usa@moog.com

For product information, visit www.moog.com/industrial
For service information, visit www.moogglobalsupport.com

Moog is a registered trademark of Moog Inc. and its subsidiaries.
All trademarks as indicated herein are the property of Moog Inc. and its subsidiaries.
CANopen is a registered trademark of CAN in Automation (CiA).
EtherCAT is a registered trademark of Beckhoff Automation GmbH.
PROFIBUS-DP is a registered trademark of PROFIBUS Nutzerorganisation e.V.
Windows is a registered trademarks of Microsoft Corporation.
©2017 Moog Inc. All rights reserved. All changes are reserved.

Direct Drive Digital Control Proportional Valves
PIM/Rev. A, November 2017, Id. CDL52302-en