

MOOG

N123-137 Series

Snap Trac Ramp Generator and General Purpose Amplifier

SPECIFICATIONS

Ramp Generator

Inputs:

- ±12VDC maximum at terminal 4.
- 0 to -15.0VDC at terminal 1.
- 0 to +15.0VDC at terminal 3.

External Control of Ramp Rate:

For positive slope:

J1 = "EXT".

Rate controlled by e1 (-E < e1 < 0).

For negative slope:

J2 = "EXT".

Rate controlled by e3 (0 < e3 < +E).

Outputs:

Steady state output at terminal 6.

$$e_6 = \left(\frac{R_5}{R_4 + R_5} \right) e_4 \text{VDC}$$

Load resistance ≥ 5KΩ.

±10VDC maximum output.

Slope of output:

$$\text{slope} = \left(\frac{-e_2}{R_9 C_3} \right) \text{Volts/sec}$$

Maximum slope = ±0.2 Volts/sec

Minimum slope = ±0.02 Volts/sec

Plug-in smaller resistor R9 (100KΩ minimum) for higher slope.

Substitute another capacitor C3 (0.1 μF minimum to 15 μF maximum) for other slopes.

This Snap Trac contains a variable rate Ramp Generator and General Purpose Amplifier. The ramp generator may be used for acceleration/deceleration control in a velocity servo, or velocity control in a position servo, or jerk control in a force loop. The general purpose amplifier may be used for low level amplification of a signal, or may be custom modified if desired.

SPECIFICATIONS

Amplifier

Inputs:

Two individual inputs at terminals 10 and 11 or differential input between terminals 10 and 11.

Input signals may range from ±0.1 to 100VDC.

Output:

Output at terminal 12.

Load impedance ≥ 5 KΩ. ±10VDC maximum output.

Gain:

General expression for amplifier gain with R16 = R18, R15 = R17,

J6 = R19 = Jumper and R25 full CW:

$$e_{12} = (e_{11} - e_{10}) (R_{16} / R_{15}) \left(1 + \frac{R_{24} + R_{25}}{R_{23}} \right)$$

Gain of General Purpose Amp (A2B):

$$e_0 / e_{IN} = [1 + (R_{24} + R_{25}) / R_{23}]$$

Gain of differential amp (A2A):

$$V_0 = \left(\frac{R_{18}}{R_{17}} \right) (e_{11} - e_{10})$$

Temperature Range:

-20°C to 50°C (-4°F to 122°F).

Power Required:

±15.0VDC at ±16 mADcC, regulated, 3-wire (±E) at terminals 7, 8, and 9.

This power is available from Model N121-132A Snap Trac Servocontroller.

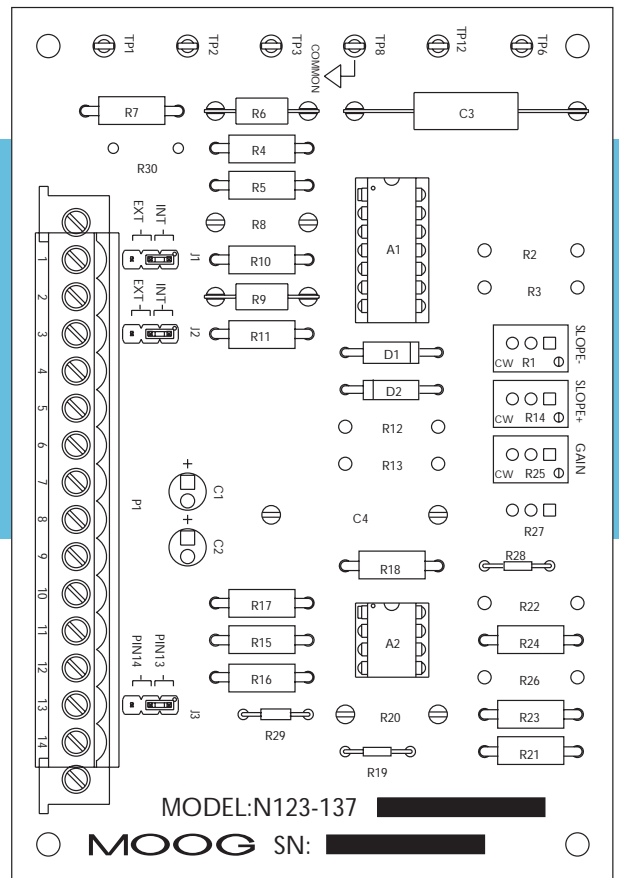

FEATURES

Construction

- Plug-in connectors for quick installation of board.
- Test points on all critical signals.
- Component standoffs on all user-configurable components.
- Twenty-turn potentiometers for all adjustable controls.
- Rugged construction with solder mask.
- Jumper selectable control of internal/external control.

N123-137 RAMP GENERATOR AND GENERAL PURPOSE AMPLIFIER SCHEMATIC

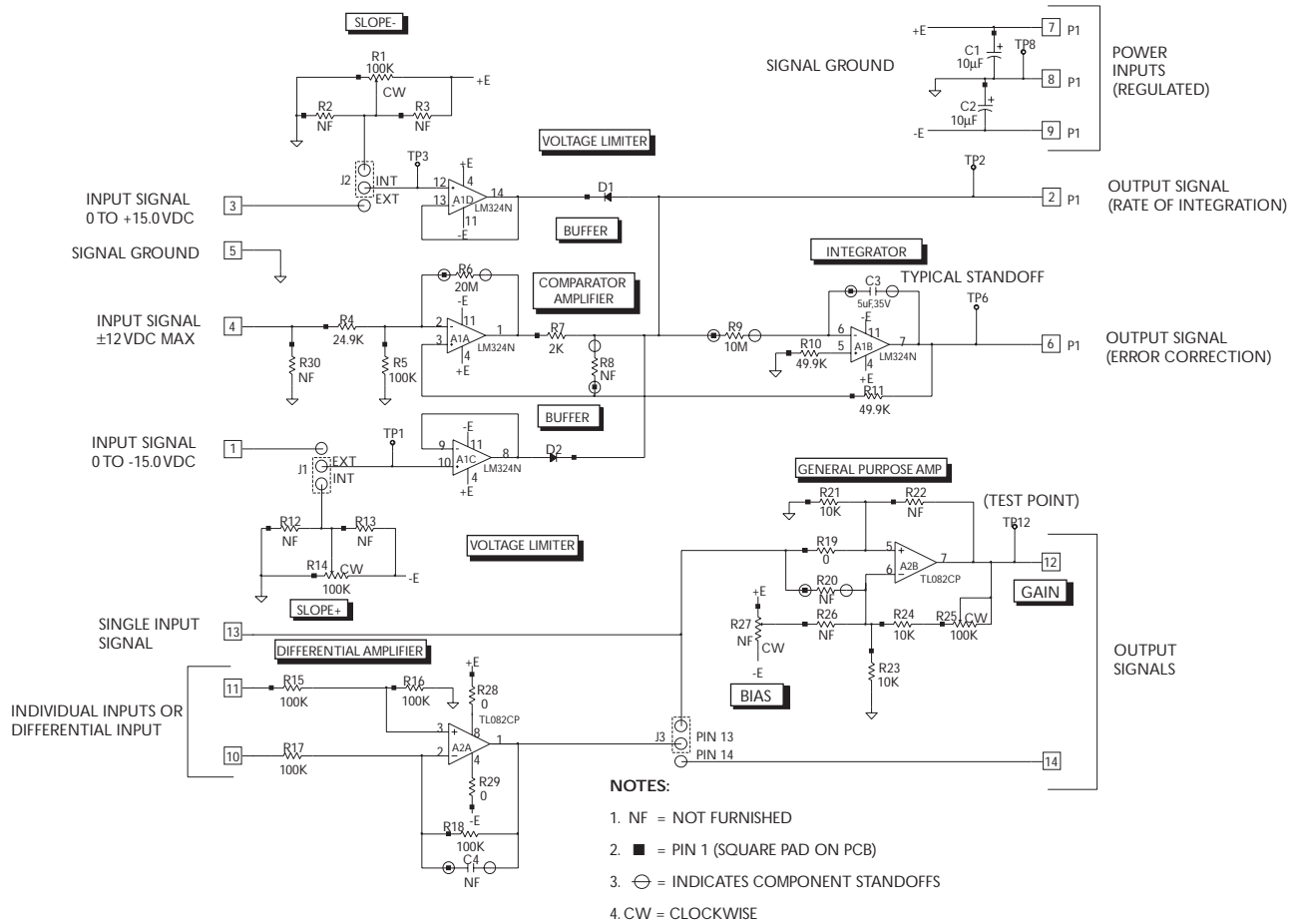

CIRCUITRY

Ramp Generator

The ramp generator consists of a comparator amplifier (A1A), a voltage limiting network (D1/A1D or D2/A1C) and an integrating operational amplifier (A1B). The input signal is applied to terminal 4 and the output is at terminal 6. Whenever the input signal changes, the output signal will change at a controlled rate until the output amplitude and polarity equal 80% of the input ($R_4 = 24.9K\Omega$, $R_5 = 100K\Omega$).

A voltage divider reduces the input voltage from terminal 4 to the inverting terminal of A1A. This reduced voltage is compared to the output voltage at terminal 6. If a difference exists, A1A drives integrating amplifier A1B to correct for the error. The rate of integration is established by R9, C3, and the voltage that can be measured at terminal 2.

Two adjustable voltage limiting networks, one positive limiter and one negative limiter, control the maximum voltage at terminal 2. This gives independent control of the negative and positive slopes of the ramp generator. When the output of the integrator satisfies the comparator, the output is maintained.

General Purpose Amplifier

A differential input amplifier (A2A) and a non-inverting amplifier (A2B) are mounted on this board for general signal amplification. Input signals are applied to terminal 10 and 11, with the output signal at terminal 12. Amplification of each stage should be between 0.1 and 10 Volts/Volt with resistor values between $10K\Omega$ and $100 K\Omega$.

ADJUSTMENTS

Ramp Generator

Positive Slope (R14) – adjusts positive ramp rate over 12:1 range.

Negative Slope (R1) – adjusts negative slope over 12:1 range.

General Purpose Amplifier

Gain (R25) – provides 6:1 amplification range of A2B.

Bias (R27) – not furnished.

MOUNTING:

Mount using Curtiss type TR-3 plastic track (Moog P/N 65419-1)

RAMP I/O CONTROL

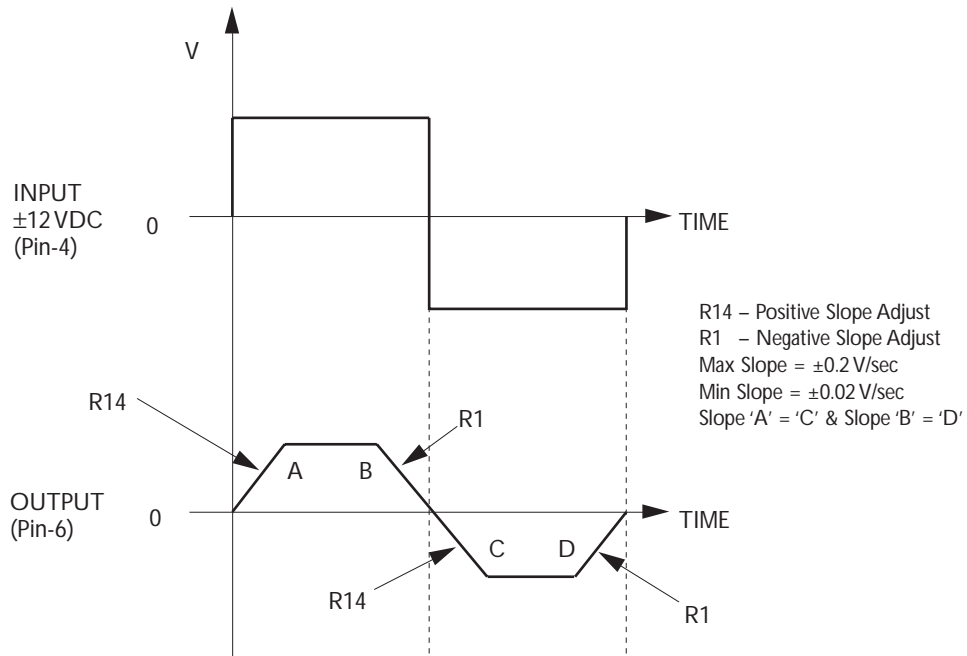

COMPARATOR CIRCUIT OPERATION

IC (A1D) compares the input signal (V_{IN} / Pin-4) to the Positive (+) switch over voltage (V_a) at A1D Pin-12. If V_{IN} (Pin-4) is $< V_a$, the output of A1D (V_o') will be its Neg (-) Sat Voltage. If V_{IN} (Pin-4) is $> V_a$, however, A1D goes into Pos (+) Saturation.

At the same time, A1C is comparing the input voltage (V_{IN}) to the 'negative' switchover voltage (V_b). If V_{IN} is $< V_b$, then A1C will be in NEG (-) Saturation. (V_b more 'negative' than V_{IN}). On the other hand, if V_{IN} is $> V_b$ (V_{IN} more 'negative' than V_b), the output of A1C will be in POS (+) Saturation.

Diodes D1 and D2 provide a voltage limiting network. A1D and diode D1 handle 'positive' input signals, while A1C and diode D2 are set-up to deal with 'negative' input signals.

MODEL N123-137 RAMP GENERATOR – FLOW

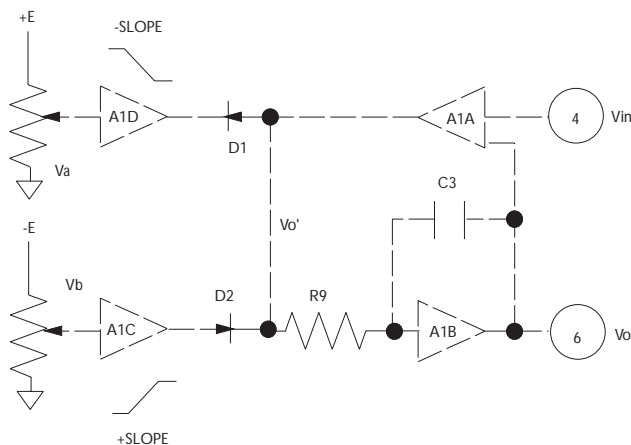

COMPARATOR WINDOW RESULTS

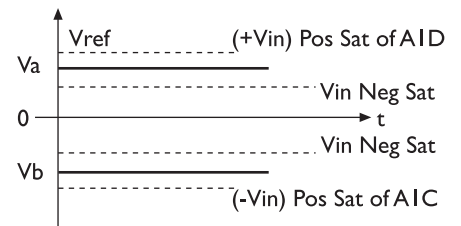

CLOSED-LOOP CONTROL OF A HYDROSTATIC DRIVE WITH LIMITED ACCELERATION AND VELOCITY FEEDBACK

Model N123-140 Frequency to Voltage Converter can be used to process signals from a bi-directional magnetic pulse pick-up for velocity feedback from a variable displacement pump and fixed displacement motor. Magnetic pulse pick-ups are often used in rugged harsh environments such as used in off-road vehicles. A DC/DC converter can be used to supply the required 3-wire, $\pm 15\text{VDC}$ regulated power source from a power supply such as a 'battery'. Model N123-137 Ramp Generator Card provides necessary acceleration/deceleration control in velocity feedback control.

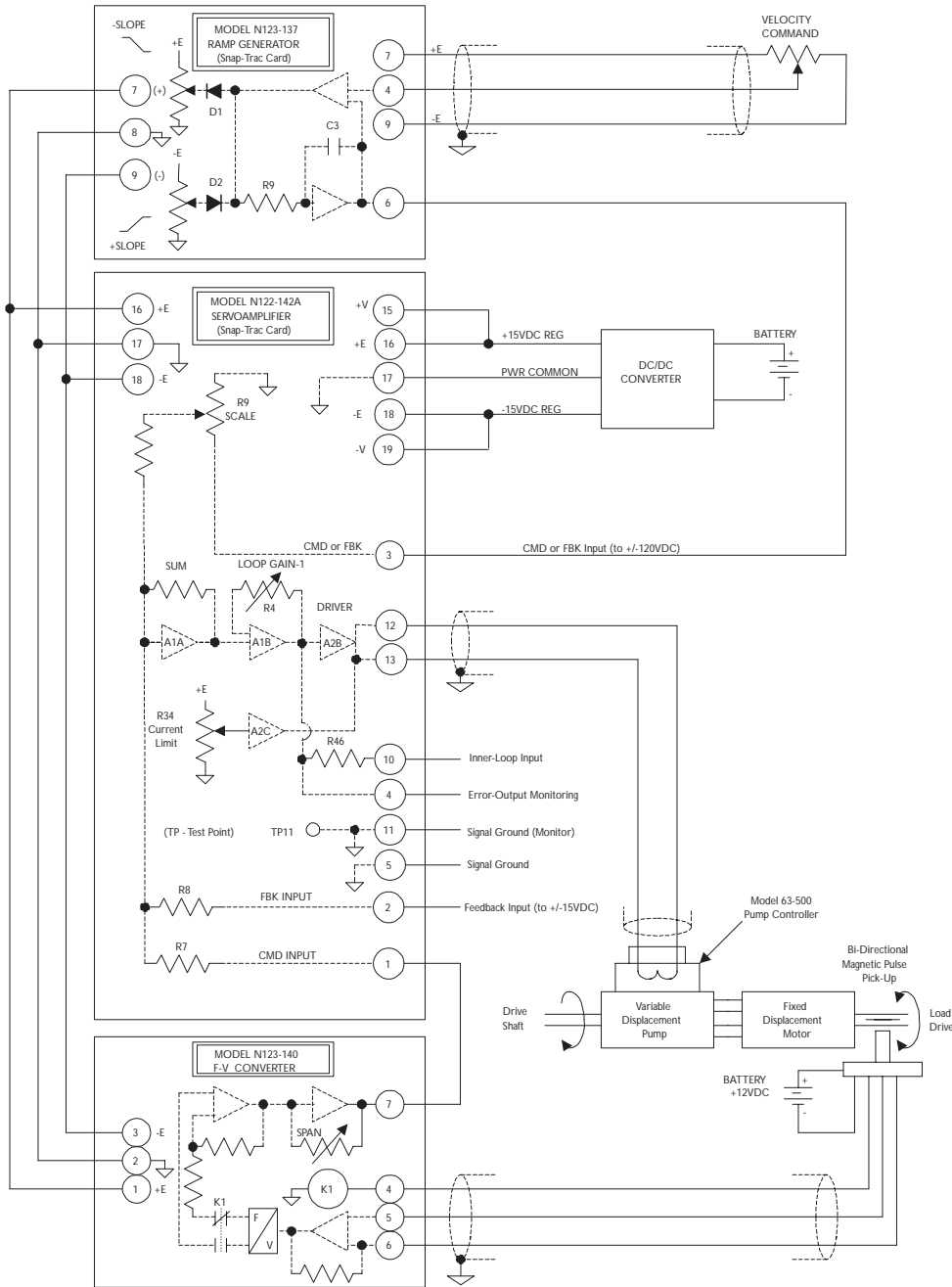

MOOG
 Industrial Controls Division
 Moog Inc., East Aurora, NY 14052-0018
 Telephone: 716/655-3000
 Fax: 716/655-1803
 Toll Free: 1-800-272-MOOG