

MOOG

NE122-205-9 Series Dual Channel Servoamplifier

SPECIFICATIONS

Proportional Gain:

4 to 190 mA/V, other 47 to 1 gains available

Integral Gain:

16 to 800 mA/V-Sec, with C4 = 5 μ F, other 47 to 1 gains available

Current Output:

to \pm 83 mA into 63 Ohm load

Voltage Output:

to \pm 10 V

Input Levels:

to \pm 15 V on terminals 7, 8, 9, and 10 to \pm 120 V on terminals 5 and 6

Drift:

0.1 mV/ $^{\circ}$ C over temperature range (with 100K input and proportional gain at 50 mA/V)

Frequency Response:

-3dB \geq 200 Hz (1 Henry load)

Power Requirements:

\pm 15 V, 20 mA; \pm 24 V @ maximum Servo valve current; + 24 V, 25 mA Relay current

Temperature Range:

0 $^{\circ}$ C to 50 $^{\circ}$ C

Connector:

DIN 41612 style C

Form Factor:

Eurocard 100 X 160 mm, 7 HP, 3U

Weight:

0.4 lb (0.18 kg)

The NE122-205-9 Dual Channel Servoamplifier is made up of two independent servoamplifiers on a single card. Each channel is designed to provide proportional or integral control for servovalves in closed-loop servosystems. This card may also be used as a simple voltage-to-current converter to drive servovalves. The NE122-205-9 is a forward compatible replacement for the E122-205-009 card.

ADJUSTMENTS

P1 Scale 2: Changes authority of signal on pin 6.

Turn CW to increase authority. Adjust to provide scaling of input at pin 6.

P2 Gain 2: Changes gain of summed inputs.

Turn CW to increase gain. Adjust for system stability.

P3 Zero 2: Changes bias voltage summed with inputs.

Adjust for desired offset between summed inputs.

P4 Dither 2: Changes authority of signal on pin 1. Turn CW to increase

authority. Adjust to provide scaling of input at pin 1. If external dither is applied to pin 1, typically adjust for \pm 10% of valve rated current.

P5 Dither 1: Changes authority of signal on pin 17. Turn CW to increase

authority. Adjust to provide scaling of input at pin 17. If external dither is applied to pin 17, typically adjust for \pm 10% of valve rated current.

P6 Zero 1: Changes bias voltage summed with inputs.

Adjust for desired offset between summed inputs.

P7 Gain 1: Changes gain of summed inputs.

Turn CW to increase gain. Adjust for system stability.

P8 Scale 1: Changes authority of signal on pin 5.

Turn CW to increase authority. Adjust to provide scaling of input at pin 5.

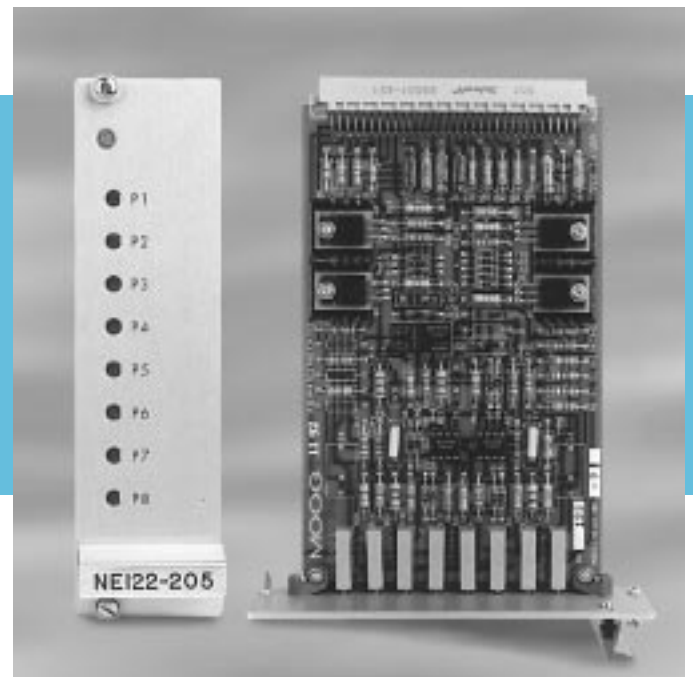

FEATURES

Proportional or Integral Control

- > Easily-accessible integrator reset function
- > Three standard inputs per channel
- > Front panel mounted independent gain, bias, scale, and dither potentiometers
- > Summed error signal easily accessible for monitoring
- > DPDT relay for integrator reset

NE122-205-9 DUAL CHANNEL SERVOAMPLIFIER SCHEMATIC

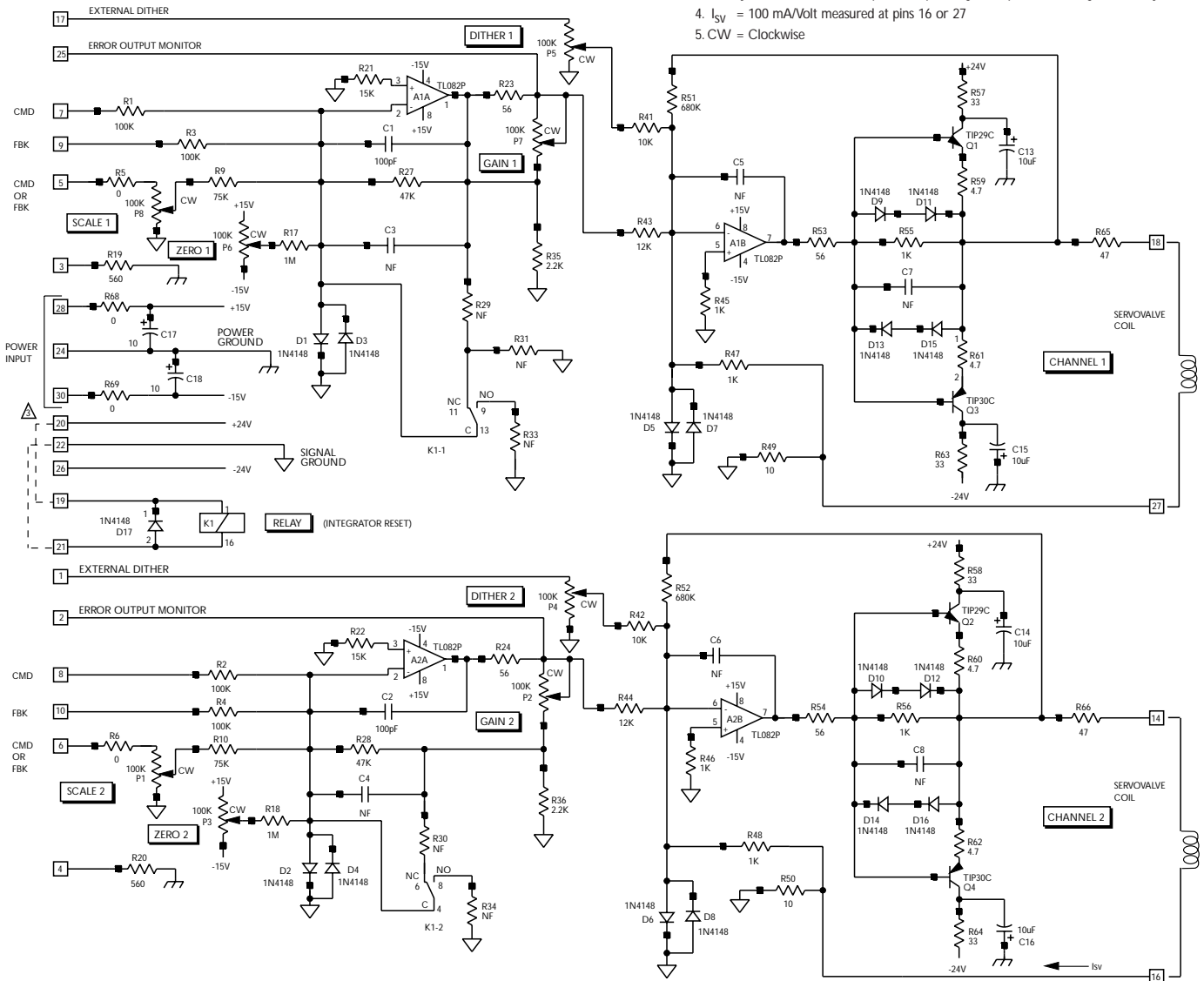

NOTES:

1. NF = not furnished
2. ■ = Pin 1 (square pin)
- ⚠ Relay Connection: Connect pin 19 to pin 20, ground pin 21 to energize the relay
4. $I_{SV} = 100 \text{ mA/Volt}$ measured at pins 16 or 27
5. CW = Clockwise

TYPICAL APPLICATIONS

Proportional Loops:

Position, pressure, force, torque control

Integral Loops:

Velocity and flow control (remove R28 and R27, install C3 and C4)
Integrator reset install R29 and R30 = 100 Ohms.

Channel 1

command signal pin 5
feedback signal pin 7
servo valve pins 18 and 27

Channel 2

command signal pin 6
feedback signal pin 8
servo valve pins 14 and 16

Channel 1

command signal pin 5
feedback signal pin 7
servo valve pins 18 and 27

Channel 2

command signal pin 6
feedback signal pin 8
servo valve pins 14 and 16

An 'Extender Card' is highly recommended to gain access to 'Test Points' and 'Adjustments' while cards are powered-up within a Eurocard Rack Assembly. (Moog ref P/N A81750-1)

The products described herein are subject to change at any time without notice, including, but not limited to, product features, specifications, and designs.

MOOG
Industrial Controls Division
Moog Inc., East Aurora, NY 14052-0018
Telephone: 716/655-3000
Fax: 716/655-1803
Toll Free: 1-800-272-MOOG