

MOOG

NF123-203A1 Series

Analog Ramp Generator

SPECIFICATIONS

Slope Range:

±1.5 to ±100 Volts/second

For flatter slopes:

Increase value of R10/R15 and/or
increase value of C8:

20 kΩ ≤ R10 ≤ 1 MΩ

20 kΩ ≤ R15 ≤ 1 MΩ

0.1 μF ≤ C8 ≤ 15 μF

Gain:

1 : 1 nominal

Temperature Range:

10°C to 50°C (50°F to 120°F)

Connector:

DIN 41612 style C

Output Voltage:

to ± 10VDC nominal

Form Factor:

Eurocard 100 x 160 mm, 7 HP, 3 U

Input Voltage:

to ± 10VDC nominal

Weight:

0.31 lb (0.14 kg)

The NF123-203A1 Circuit Card is designed to transform a step input into a ramp output. The card can be used to control velocity in a position servo, acceleration in a velocity servo, or jerk in a force servo. The card includes circuitry to provide independent control of acceleration and deceleration when used in velocity-control servosystems.

The NF123-203A1 Analog Ramp Generator is a forward compatible replacement for the F123-203-A001.

Figure 1

- **Key:**
- Smoothing 'OFF'
- Smoothing 'ON'

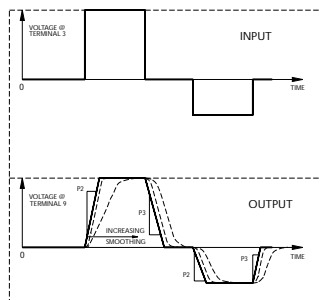

FEATURES

➤ Ramp Controls

Separate adjustment of increasing and decreasing slopes.
Solid-state switches for durability.
Compatible with remote-mounted potentiometers for remote adjustment of slopes.

➤ Output Smoothing

Provides smooth transitions at beginning and end of ramp.
Adjustable with a potentiometer.
Turned on or off with a jumper.

➤ Front-Panel Adjustments

Provide quick access to slopes, smoothing, and bias.

➤ Front-Panel Test Points

Allow for easy set-up, test, & monitoring of signals.

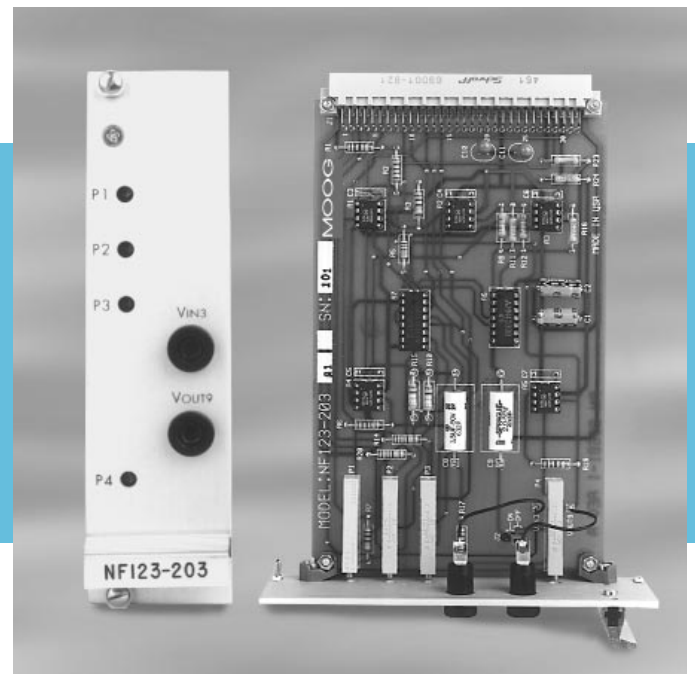

ADJUSTMENTS

P1 Bias: Changes output voltage at terminal 9 relative to input voltage at terminal 3. Turn CW to shift output in the negative direction. Adjust for desired offset (typically, zero).

P2 Ascending Slope: Changes slope marked "P2" in Figure 1. Turn CW to increase slope. Adjust for desired ramp rate.

P3 Descending Slope: Changes slope marked "P3" in Figure 1. Turn CW to increase slope. Adjust for desired ramp rate.

P4 Smoothing: Changes amount of rounding in curves marked "smoothing on" in Figure 1. Turn CW to increase smoothing. Adjust to eliminate sharp corners at beginning and end of ramp.

NOTE: Smoothing jumper, J2, must be in ON position to enable smoothing.

NF123-203A1 ANALOG RAMP GENERATOR SCHEMATIC

NOTES:

1. NF = NOT FURNISHED
2. ■ = PIN 1 (SQUARE PAD ON PCB)
3. ⊖ = COMPONENT ON STANDOFF
4. ● = TEST POINTS (FRONT PANEL)
5. CW = CLOCKWISE

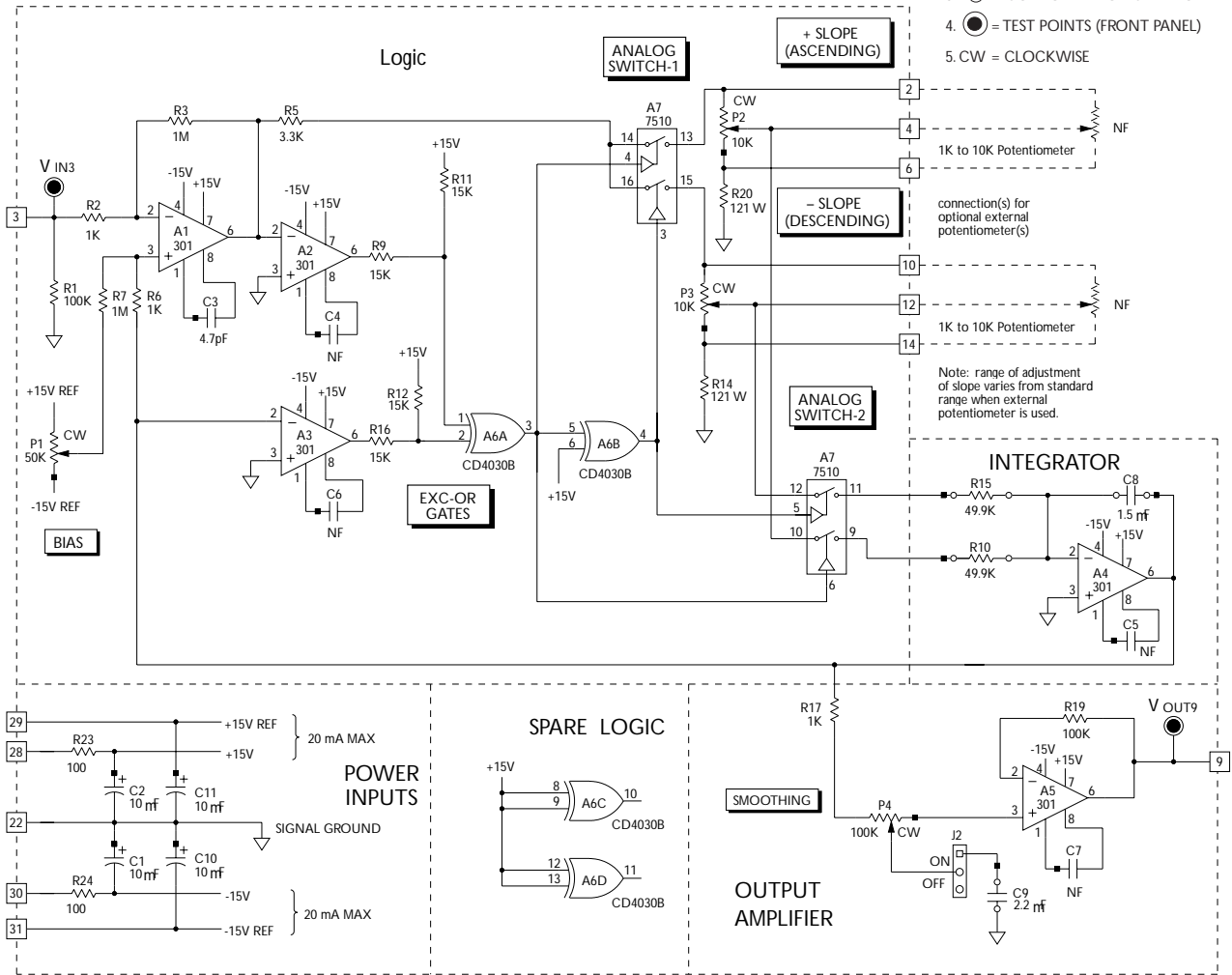

TYPICAL APPLICATIONS

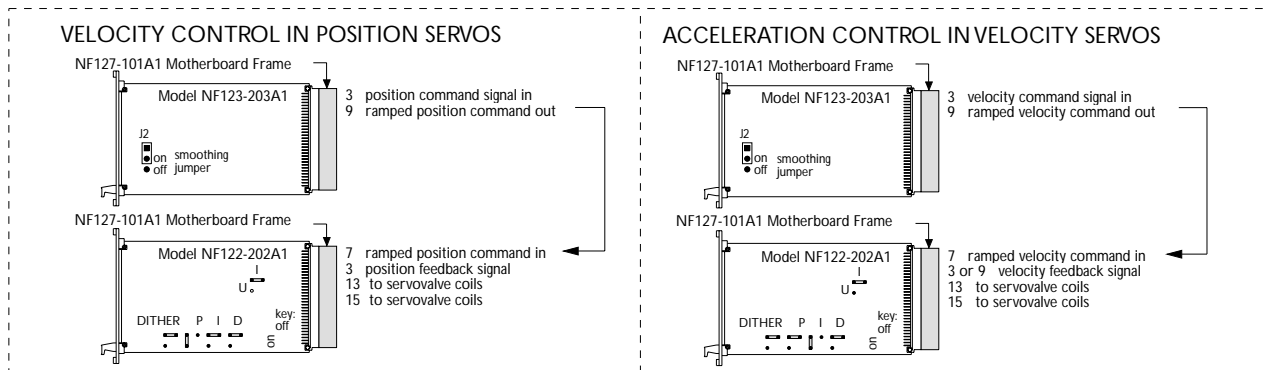

V in 3 - Input monitoring test point
 V out 9 - Output monitoring test point

NOTE: An "Extender Card" is highly recommended to gain access to test points and adjustments while cards are powered-up within a Eurocard Rack Assembly. (Moog ref P/N A81750-1)

CIRCUITRY

Model NF123-203 generates a Ramp of adjustable slope. The output voltage of the card is ramped from its current value to the voltage applied at the card input. The slope can be either 'ascending' or 'descending' depending on whether the input voltage is greater or less than the reference voltage. When the ramp is completed, the output voltage is equal to the input voltage in amplitude and sign.

The Ramp Card can be used as a speed control device to allow precise control of 'acceleration' and 'deceleration'. As a position controlling device, it allows movement at a constant and adjustable speed.

The input is applied at terminal 3 and the output is at terminal 9. Integrating amplifier (A4) controls the slope rate at terminal 9. The Slope Range may be modified through component sizing. Specific modifications include increasing the value of R10 for 'ascending' (+) slopes and/or R15 for 'decreasing' (-) slopes. Increasing the value of capacitor C8 or resistor R10 will 'decrease' the slope. The Time Constant (T) of the R-C network will determine the rate of integration (ramp rate in Volts/sec). $T=R_{10}C_8$ for ascending (+) slope and $R_{15}C_8$ for decreasing (-) slope.

Exclusive-OR Gates (A6A and A6B) provide solid-state switching control of CMOS Analog Switching device (A7) used for precision slope 'polarity' selection and ramp control.

V out-9

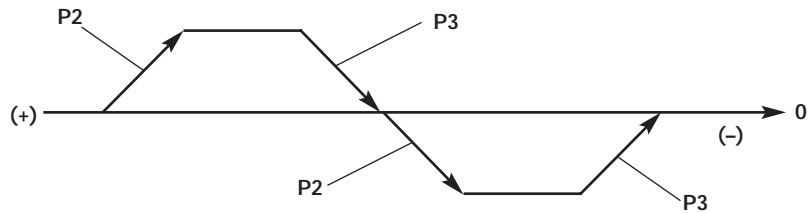

Figure 2

POSITIVE Slope pot (P2) adjusts positive (+) ramp rate (fig. 2) while the NEGATIVE Slope pot (P3) adjusts the negative (-) ramp rate. P4 provides SMOOTHING of the output waveform by eliminating 'sharp' corners at the beginning and end of ramp as shown in Figure 1. P1 provides BIAS control by changing Output voltage at terminal 9 relative to Input voltage at terminal 3. The desired offset is typically 'zero'.

TWO AXIS PROGRAMMABLE LOGIC CONTROLLER (PLC) SERVO SYSTEM

A two-axis system can be configured so that all analog signal processing takes place using electronics in order to utilize a controller having only discrete inputs/outputs.

For the linear Y-axis servo, the Current to Voltage Converter interfaces between the 4mA-20mA current command source from a Programmable Logic Controller (PLC) and the voltage input of the Ramp Generator. The Ramp Generator provides variable acceleration/deceleration control in response to a step input. The servoamplifier, in conjunction with the position feedback transducer and conditioning electronics, provides closed-loop control of the valve and actuator. In addition, the servoamplifier provides DC source power to all analog servoelectronics.

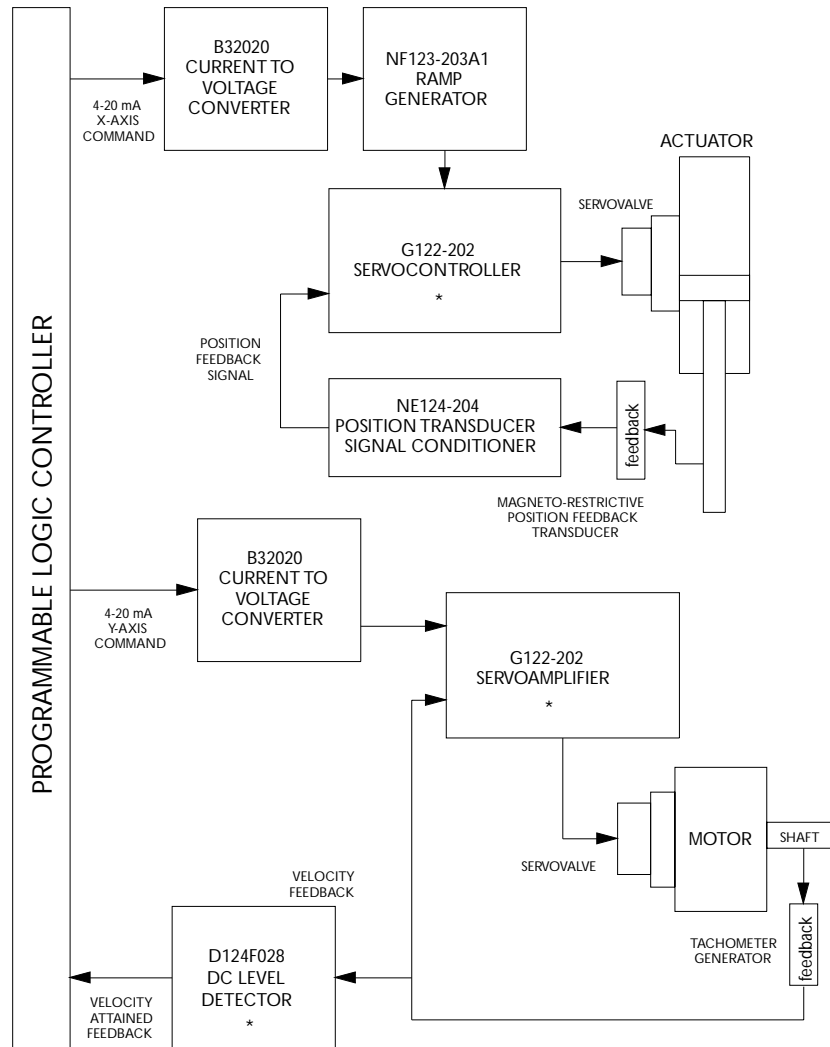

* Other models/types available. Consult Moog factory.

Eurocard Example

Suggested Setup Procedure:
Consult the Factory.

MOOG
Industrial Controls Division
Moog Inc., East Aurora, NY 14052-0018
Telephone: 716/655-3000
Fax: 716/655-1803
Toll Free: 1-800-272-MOOG