

Application Notes

1 Scope

These application notes are a guide to applying the G123-814 dual PWM Amplifier. They tell you how to install, connect and adjust the PWM Amplifier. They do not tell you how to select proportional valves or how to design a closed loop system.

2 Description

The G123-814 Dual PWM Amplifier is used to drive both coils of a three position 24V solenoid operated proportional valve. It is specifically intended for use in low end closed loop applications. It allows a very low cost proportional valve to be used where normally a much more expensive servovalve would be needed. Coupling it with its companion servoamplifier, the G122-824, and a proportional valve, produces an economical closed loop solution.

For a more detailed description see data sheet G123-814 E01.01.

3 Applicability

The G123-814-001 has been structured to operate in a closed loop and optimised with a Hydrolux WP series proportional valve. The important specifications considered were the coils, which are 24V @ 800mA, and the spool overlap, which is 12%. Output current is 25% higher than nominal to ensure maximum flow is not overly compromised by valve production tolerances and spool Bernoulli forces. The deadband compensation circuit, that cancels the spool overlap, has been optimised on a flow stand and during field applications. The dead band compensation is not user adjustable. Applying this amplifier to other valves with the same specifications will produce the same performance as achieved with the Hydrolux valve.

The G12-814 is not suitable for traditional open loop proportional valve applications. Because the deadband compensation circuit cancels the spool overlap, it is highly unlikely that a zero flow condition will result from zero coil current.

4 Installation

4.1 Placement

A horizontal DIN rail, mounted on the vertical rear surface of an industrial steel enclosure, is the intended method of mounting. The rail release clip of the G123-814 should face down, so the front panel and terminal identifications are readable and so the internal electronics receive a cooling air flow. An important consideration for the placement of the module is electro magnetic interference (EMI) from other equipment in the enclosure. For instance, VF and AC servo drives can produce high levels of EMI. Always check the EMC compliance of other equipment before placing the G123-814 close by.

4.2 Cooling

Vents in the top and bottom sides of the G123-814 case provide cooling for the electronics inside. These vents should be left clear. It is important to ensure that equipment below does not produce hot exhaust air that heats up the G123-814.

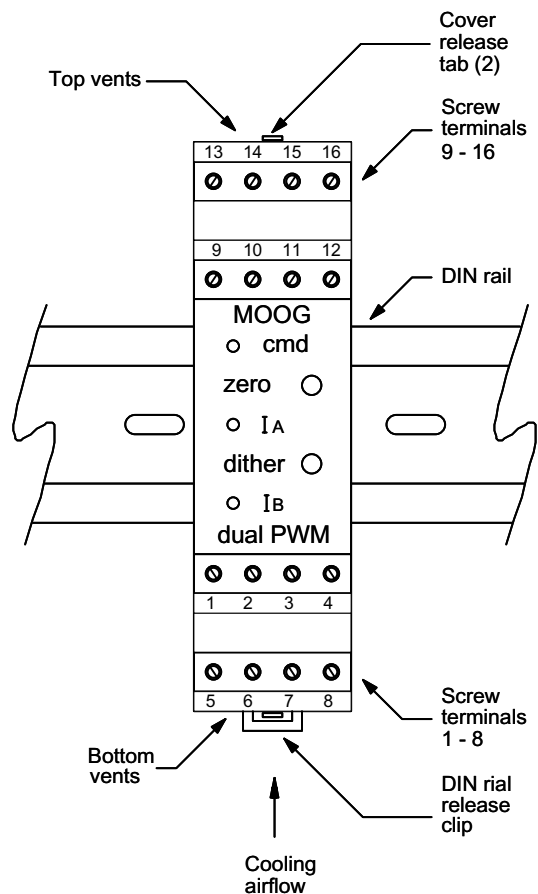

4.3 Wiring

The use of crimp “boot lace ferrules” is recommended for the screw terminals. Allow sufficient cable length so the circuit card can be withdrawn from its case with the wires still connected. This enables the circuit to be checked while the card is still connected and operating. An extra 100mm, for cables going outside the enclosure, as well as wires connecting to adjacent DIN rail units, is adequate.

Cables to the valve coils carry one Amp and so should be sized accordingly. A conductor size of 0.2mm² is generally rated at one Amp and is suitable for cable lengths up to five metres. Longer cables should have 0.5mm² conductors.

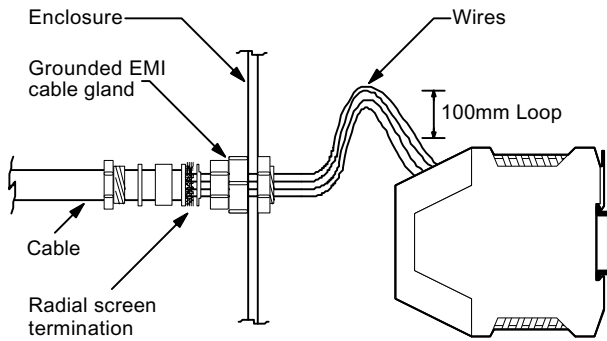

Preferred Wiring

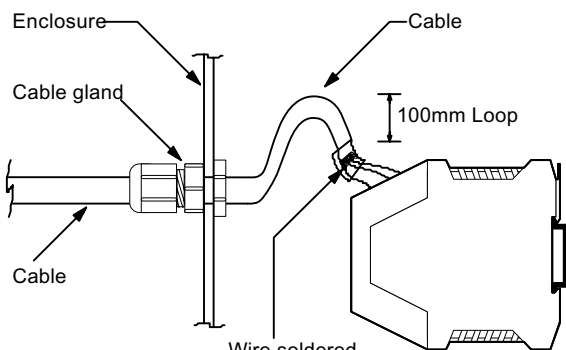

Alternative Wiring

4.4 EMC

The G123-814 emits radiation well below the level called for in its CE mark test. However, the cables to the valve coils should be screened to ensure no interfering radiation is emitted. Connect the screens to chassis ground at each end. Use terminals 10 and 14 on the G123-814.

Immunity from external interfering radiation is dependent on careful wiring techniques. The accepted method is to use screened cables for all connections and to radially terminate the cable screens, in an appropriate grounded cable gland, at the point of entry into the industrial steel enclosure. If this is not possible, chassis ground screw terminals are provided on the G123-814. Exposed wires should be kept to a minimum length. Connect the screens at both ends of the cable to chassis ground.

5 Power supply

24V nominal, 22 to 28V

45mA @ 24V without a load.

If an unregulated supply is used the bottom of the ripple waveform is not to fall below 22V.

6 Input signal

The input command is 0 to ±10V. Input resistance is 100k Ohm. An input of 0 to +10V causes a proportional current of 0 to 1 Amp in coil A. 0 to -10V causes a proportional current of 0 to 1 Amp in coil B. These outputs result from the input connected to the positive terminal. Connecting the input to the negative terminal reverses the outputs. Connect the unused input to signal ground (terminal 7). Connect the input signal ground to the signal ground of the device supplying the input signal.

7 Outputs

Both sides of each valve coil must be wired back to the G123-814. Do not place any diodes across the coil. See paragraph 4.3 for advice on cable size.

8 Enable input

The output current drivers will not deliver current to the valve coils until the enable input has a voltage of between 10 and 24V connected to it.

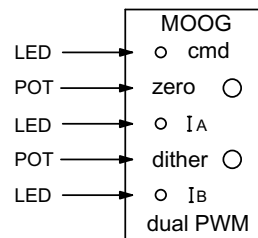

9 Dither

The front panel dither pot allows up to 100mA of 100Hz dither to be superimposed on both coil currents. Dither is used to overcome resolution limitations of the proportional valve and is normally used if performance is being compromised by the resolution of the valve. Optimum dither is achieved by firstly increasing the level until it can be detected in the load (the controlled variable, such as position). When this condition is reached, reduce the level until its influence is just undetectable in the load.

10 Zero

The zero pot allows up to 150mA coil current offset. Clockwise rotation increases the offset to coil A. With your desired zero input signal adjust the zero pot for the desired valve output flow.

11 Front panel indicators

The “cmd” (command) LED indicates the polarity and level of the input signal. Red is positive and green is negative.

The IA and IB LEDs indicate the level of the corresponding coil current.

12 Withdrawing the circuit card from its case

If access to the circuit is required, the circuit card needs to be withdrawn from its case. To do this, push one tab in with a pen or screwdriver while gently pulling on the top cover on that side. The cover will release approximately one mm. Repeat on the other side and withdraw the cover and circuit card until the required circuit points are exposed. The rigidity of the connecting wires will hold the circuit card in position while measurements are made.

13 Block-wiring diagram

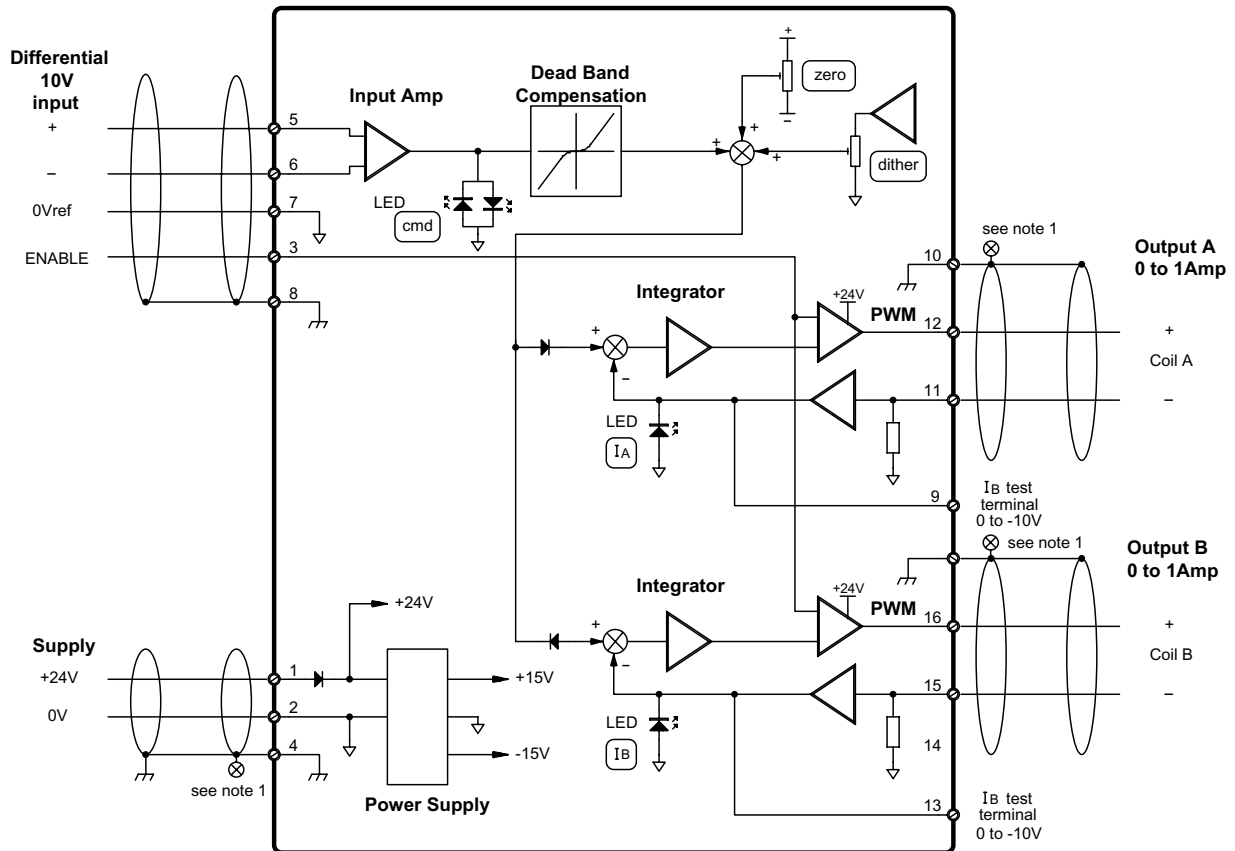

⊗ Note: 1. Connect cable screen to enclosure cable gland or chassis ground terminal on G123-814.

14 Specifications

Input: Differential
0 to $\pm 10V$
100 kOhm input resistance

Enable: +10V to +24V
2mA @ 24V

Outputs: Dual PWM @ 24kHz
1.0A $\pm 0.1A$

Maximum coil resistance: 22 Ohm

Coil current test terminals: 0 to -10V for 0 to 1A current

Deadband compensation: $\pm 12\%$ nominal, not user adjustable

Dither: 100 Hz
0 to 0.1A

Zero: 0 to $\pm 0.15A$

Front panel indicators: Command – positive = red
negative = green
I(A) = red
I(B) = green

Supply: 24V nominal, 22 to 28V
45mA @ 24V, no load

Mounting: DIN rail
IP 20

Temperature: 0 to +40°C

Dimensions: 100W x 108H x 22.5D

Weight: 130g

CE mark: EN50081.1 emission
EN50082.2 immunity

C tick: AS4251.1 emission

This page left blank intentionally

MOOG

Moog Australia Pty. Ltd. ABN 50 005 599 584, 14 Miles Street, Mulgrave, Vic 3170. Telephone: + 61 3 9561 6044. Fax: + 61 3 9562 0246.

Moog Australia Pty. Ltd. pursues a policy of continuous development and reserves the right to alter designs and specifications without prior notice. Information contained herein is for guidance only and does not form part of a contract.
Australia: Melbourne ■ Austria: Vienna ■ Brazil: São Paulo ■ Denmark: Birkerød ■ England: Tewkesbury ■ Finland: Espoo ■ France: Rungis ■ Germany: Böblingen, Dusseldorf ■ Hong Kong: Shatin ■ India: Bangalore
Ireland: Ringaskiddy ■ Italy: Malnate (VA) ■ Japan: Hiratsuka ■ Korea: Kwangju-Kun ■ Philippines: Baguio City ■ Singapore: Singapore ■ Sweden: Askim ■ USA: East Aurora (NY)