

Servo- and Proportional Control Valves with integrated electronics D661 Series · ISO 4401 Size 05

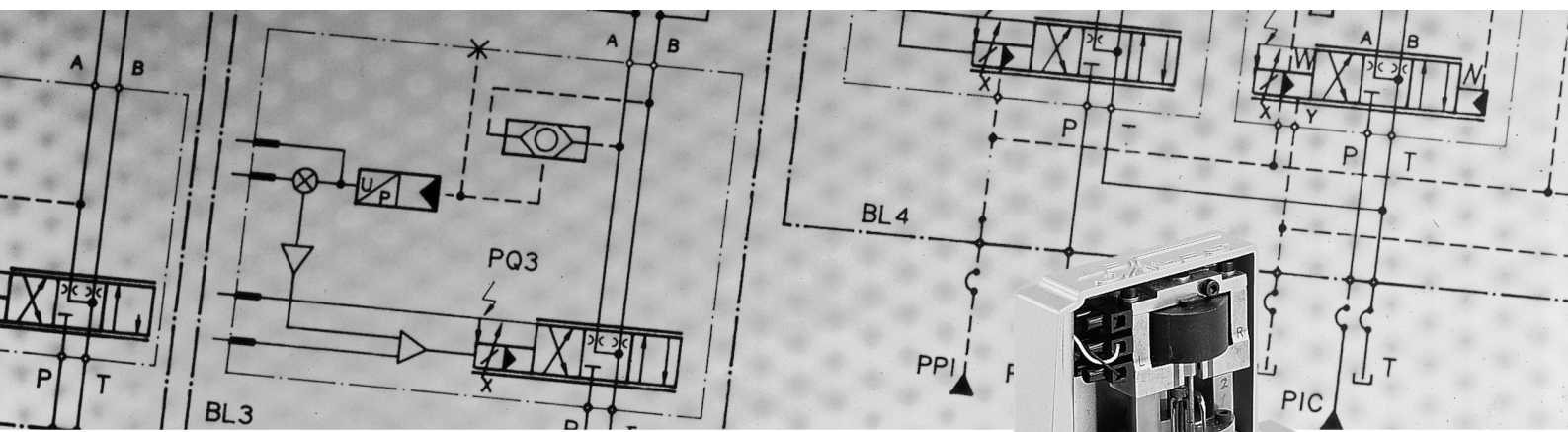

Operating Instructions

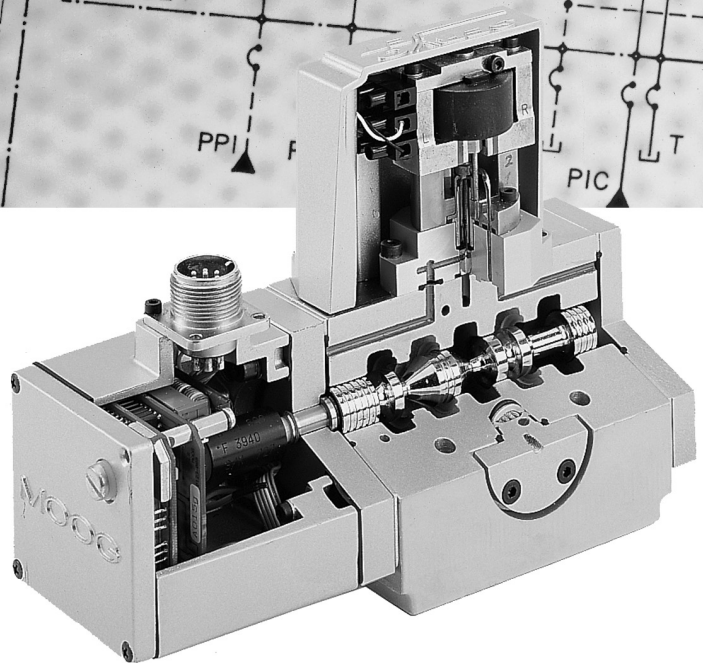

Our quality management system
is certified in accordance with
DIN EN ISO 9001



Table of contents

1.	Safety Instructions	page 3
2.	Description	page 4
3.	Installation	page 7
4.	Setting up	page 14
5.	Maintenance	page 15
6.	Malfunctions, Causes and Elimination	page 15
7.	Declaration of Manufacturer	page 16
8.	Tools, Spare Parts and Accessories	page 16
9.	Ordering Information	page 18

1. Safety Instructions

1.1 Warnings and symbols



refers to special orders and prohibitions to prevent damage



refers to special orders and prohibitions to prevent injury or property damage

1.2 Correct application

- 1.2.1 The valves series D661 are control valves suited for electrohydraulic position-, velocity-, pressure- and force control. The valves are designed for flow rate control in hydraulic systems that operate with mineral oil based fluids. Others on request.



Using the valves for purposes other than those mentioned above is considered contrary to the intended use. The user bears entirely the risk of such misuse.

Correct application involves also observing the operating instruction and complying with the inspection and maintenance directives.

1.3 Organizational measures

- 1.3.1 We recommend to include this operating instruction into the maintenance plan of the machine / plant.
- 1.3.2 In addition to the operating instruction, observe also all other generally applicable legal and other mandatory regulations relevant to accident prevention and environmental protection. Instruct the operator accordingly.
- 1.3.3 All safety and danger prevention instructions of the machine/plant must meet the requirements of EN 982.

1.4 Selection and qualification of personnel

- 1.4.1 Only well-trained and instructed personnel are allowed to work with MOOG control valves.

- 1.4.2 Work with electrohydraulic valves must be carried out only by personnel having special knowledge and experience in plants running with electrohydraulic controls.

1.5 Safety instructions for specific operational phases

- 1.5.1 Take the necessary precautions to ensure that the machine / plant is used only when in a safe and reliable state.
- 1.5.2 Check the machine / plant at least once per working shift for obvious damage and defects (i.e. leakage). Report any changes to the responsible group / person immediately. If necessary, stop the machine immediately and secure it.
- 1.5.3 In the event of malfunctions, stop the machine / plant immediately and secure it. Have any defects rectified immediately.
- 1.5.4 If the machine / plant is completely shut down for maintenance and repair work at the valve, it must be secured against inadvertent start up by:



- Locking the principal control elements and removing the key.
- attaching a warning sign to the main switch.

1.6 Safety instructions for the operation of hydraulic plants

- 1.6.1 Work on electrohydraulic equipment must be carried out only by personnel having special knowledge and experience in electrohydraulic controls.
- 1.6.2 Check all lines, hoses and fittings of the plant regularly for leaks and obvious damage. Repair damage immediately. Splashed oil may cause injury and fire.
- 1.6.3 Before removing the valve depressurize all system sections to be opened, pressure lines and accumulators of the hydraulic system in accordance with the specific instructions for the plant.
- 1.6.4 When handling oil, grease and other chemical substances, observe safety regulations valid for each product.



2. Description

- Series ...G** Servovalve with nozzle-flapper type pilot stage, spool in bushing, without additional mechanical feedback
- Series ...S** Servovalve configured like version ...G, but with additional mechanical feedback
- Series ...H** Servovalve configured like version ...S, but with improved performance (high response)
- Series ...P...A/B** Proportional valve with contamination insensitive ServoJet pilot stage, spool in body, without additional mechanical feedback
- Series ...P...F/G** Proportional valve configured like version ...P...A/B, but with nozzle flapper pilot stage and additional mechanical feedback

2.1 Design features

2.1.1 Control valves general

The **Servovalves** D661-...G, S and H Series and the **Proportional Flow Control Valves** D661-...P Series are throttle valves for 2-, 3- and 4-way applications. With proportional flow control valves also 5-way applications are possible. These valves are suitable for electrohydraulic position, velocity, pressure or force control systems with high dynamic response requirements.

2.1.2 Servo valves D661-...G, S and H

2.1.2.1 General

The spool of the main stage is driven by a nozzle flapper pilot stage, optional with or without additional mechanical feedback. The D661-...G Series will also be available with ServoJet pilot stage in the near future (see D661-...P...A/B).

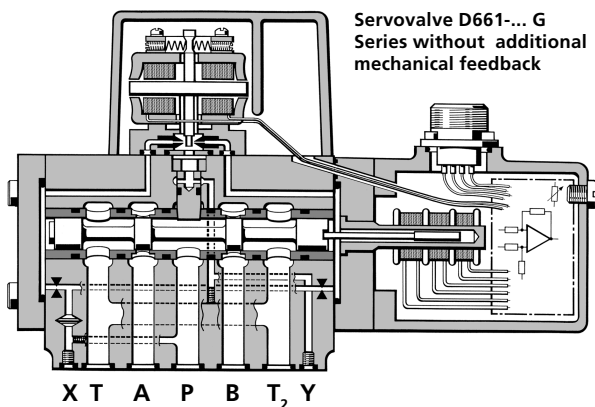

With versions D661-...S and H in case of an electrical supply failure the spool is moved into a preferred position by action of an additional mechanical feedback.

2.1.2.2 Operating principle of the two-stage valve

An electric input signal (flow rate command) is applied to the integrated control amplifier which drives a current through the coils of the pilot stage torque motor. Thus the deflected nozzle-flapper system produces a pressure difference across the drive areas of the spool and effects its movement. The position transducer which is excited via an oscillator measures the position of the spool (actual value, position voltage).

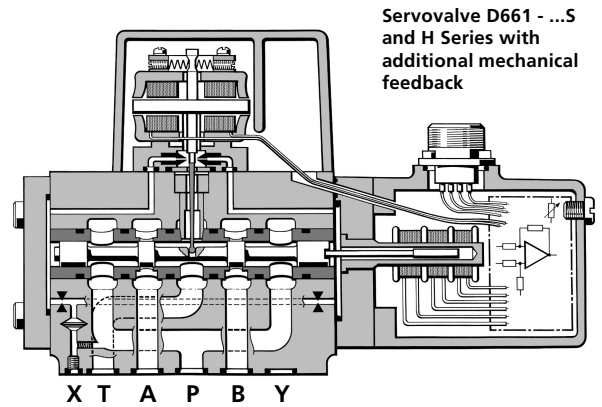

This signal is then rectified by a demodulator and is fed back to the control amplifier where it is compared with the command signal. The control amplifier drives the torque motor until command voltage and feedback voltage are equal. Thus, the position of the spool is proportional to the electric command signal.

2.1.3 Proportional flow control valve D661-...P

2.1.3.1 Operation

The nozzle flapper design of the pilot stage has been converted into an improved version with jetpipe amplifier (ServoJet).

2-stage Proportional Valve D661-...P...A/B Series

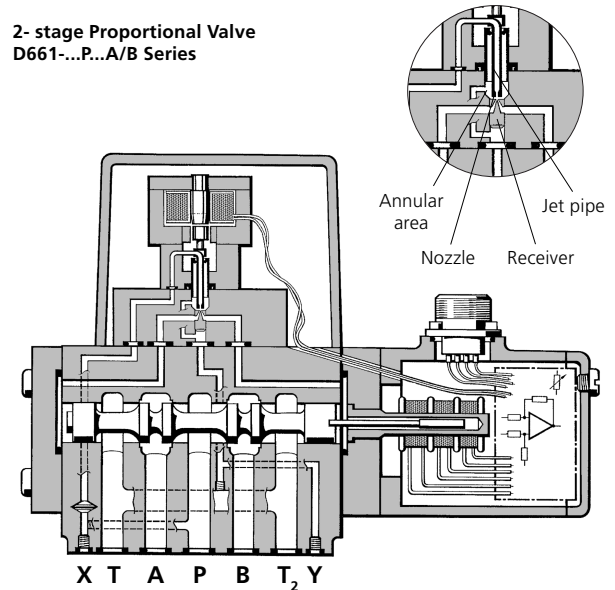

The ServoJet pilot stage consists mainly of torque motor, jet pipe and receiver.

A current through the coil displaces the jet pipe from neutral. This displacement combined with the special shape of the nozzle directs a focussed fluid jet more into one receiver bore than into the other.

The jet now produces a pressure difference in the control ports. This pressure difference results in a pilot flow, which in turn causes a spool displacement. The pilot stage drain is through the annular area around the nozzle to tank.

2.1.3.2 Operating principle of the two-stage valve

An electric input signal (flow rate command) is applied to the integrated control amplifier which drives a current through the coil of the pilot stage torque motor. The thus deflected jet-pipe produces a pressure difference across the

drive areas of the spool and effects its movement. The position transducer which is excited via an oscillator measures the position of the spool (actual value, position voltage). This signal is then demodulated and fed back to the controller where it is compared with the command signal. The controller drives the torque motor until the error between command signal and feedback signal is zero. Thus the position of the spool is proportional to the electric command signal.

2.1.4 D661-...P Series fail-safe version

For applications with proportional control valves where certain safety regulations are applicable, a defined metering spool position is needed in order to avoid potential damage. **Therefore fail-safe versions are offered as an option for the MOOG proportional valves.**

After external triggering this fail-safe function causes a defined metering spool position.

2.1.4.1 Mechanical Fail-safe version (biased pilot stage)

The safe position of the spool will be obtained after cut-off of pilot pressure supply (external pilot connection) or operating pressure supply (internal pilot connection). This safe position can only be obtained with < 1 bar pilot pressure.

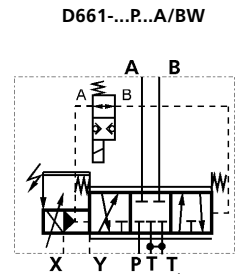
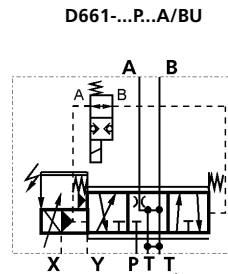
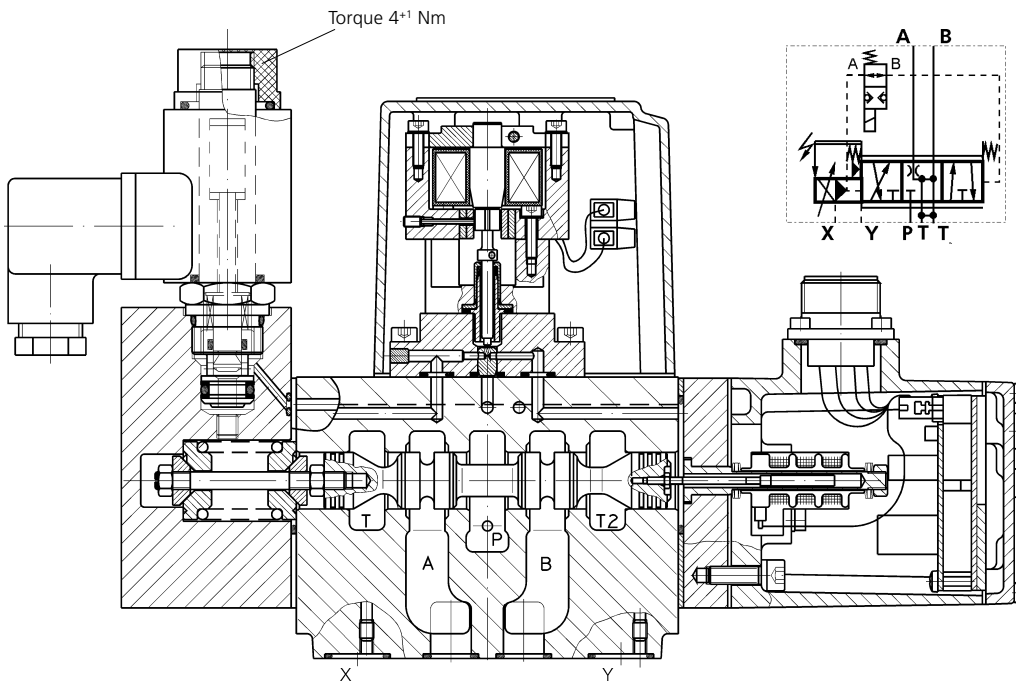

Proportional Valve
D661-...P...A/BW
and D661-...P...A/BU Series
with electrically operated
fail-safe function

Proportional Valve
D661-...P...AP Series
with electrically operated
fail-safe function

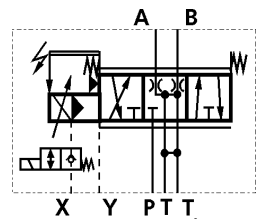
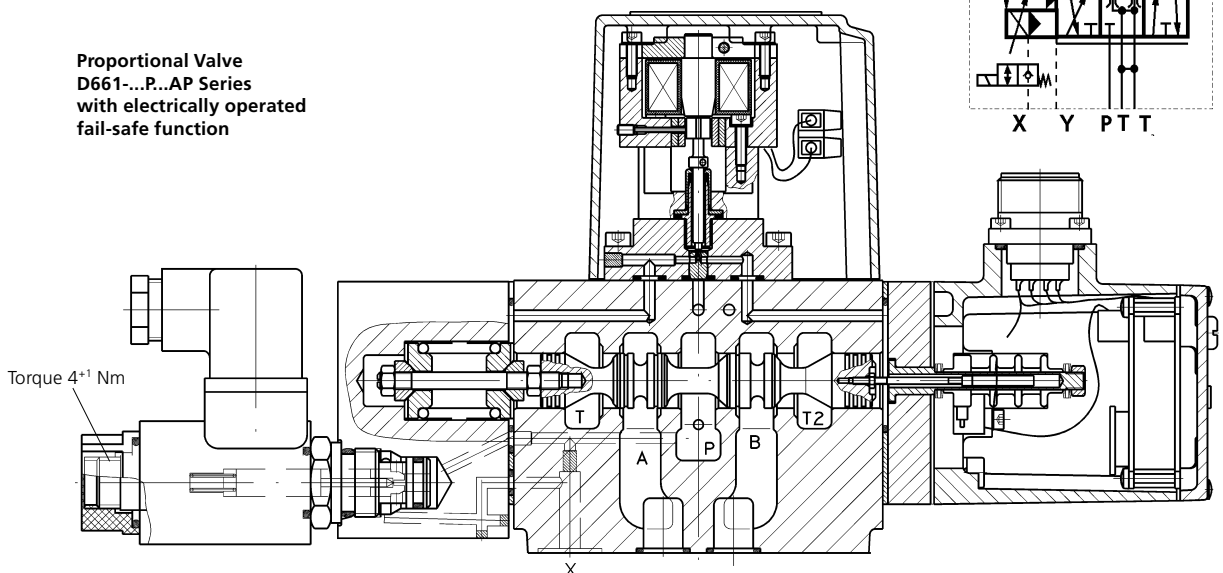

D661 Series



With fail-safe versions **R** and **L** a defined spool position is reached when the electric supply to the valve electronics is switched off while the pilot pressure is still effective. With version **M** the resulting spool position is undefined.

2.1.4.2 Electrically operated fail-safe version

The safe position of the spool will be obtained after switching off the integrated 2/2-way solenoid seat valve.



With fail-safe versions **W**, **U** and **G** after cut-off of the solenoid the spool moves to midposition. When the electric supply to the valve electronics is switched off while the pilot pressure is still effective and the solenoid is still switched on the spool will move to a defined end position with versions **U** and **G**.



With fail-safe version **P** the integrated seat valve will shut off the external pilot pressure after switching off the solenoid.

Electric characteristics of the 2/2-way solenoid valve

Function electro magnetic
Nominal voltage 24 VDC
Nominal power 12 W

Connector wiring

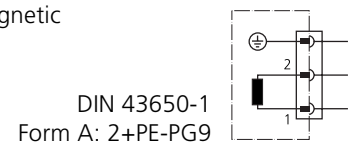

Cutting off the 24 VDC supply to the solenoid operated 2/2-way seat valve



To protect relays contacts or semiconductors against burning off a Zener diode is required



Consider inductive load of the solenoid coil!

2.2 Technical Data

Series D661-... (for code letter of valve version see pages 18/19)			G	S...F	S...G	H	P...A	P...B
Mounting pattern	ISO 4401, version ..G.. with second tank port With series D661-...P...B 5-way version the port designated T ₂ is used as second pressure port P ₂		ISO 4401 - 05 - 05 - 0 - 94				ISO 4401 - 05 - 05 - 0 - 94	
Mass		[kg]	5,7	5,5	4,2	5,5	5,6	4,7
Rated flow Q_N		[l/min]	see nameplate of the valve				see nameplate of the valve	
	at Δp _N = 5 bar per land, tolerance ±10 %							
Null leakage flow¹⁾	total, max.	[l/min]	3,0 to 5,0 (S...F 2,5 to 4,0)				3,5	4,4
Pilot leakage flow¹⁾	pilot stage only	[l/min]	2,5	1,4	2,5	2,5	1,7	2,6
Pilot flow¹⁾	max, for 100% step input	[l/min]	2,5	1,4	2,5	2,5	1,7	2,6
Max. operating pressure p_{max}								
	Main stage	ports P, A, B	[bar]	350			350	
		port T, (T ₂) with Y internal	[bar]	20% of pilot pressure, max. 100			210	
		port T, (T ₂) with Y external	[bar]	350			350	
	pilot stage	regular version	[bar]	210			280	
		with dropping orifice (on request)	[bar]	350			350	
Temperature range	Ambient	[°C]	- 20 to + 60				- 20 to + 60	
	Fluid	[°C]	- 20 to + 80				- 20 to + 80	
Operating fluid			mineral oil based hydraulic fluid according to DIN 51524, part 1 to 3, others upon request				mineral oil based hydraulic fluid according to DIN 51524, part 1 to 3, others upon request	
	Viscosity	recommended	[mm ² /s]	15 to 45			15 to 45	
		allowable	[mm ² /s]	5 to 400			5 to 400	
System filter			High pressure filter, mounted in the main flow without bypass, but with dirt alarm				High pressure filter, mounted in the main flow without bypass, but with dirt alarm	
Class of cleanliness according to								
	ISO 4406		16 / 13 or better ²⁾				16 / 13 or better ²⁾	
	NAS 1638		7 or better ²⁾				7 or better ²⁾	
Filter rating	for normal operation		$\beta_{15} \geq 75$ (15 µm absolute)				$\beta_{15} \geq 75$ (15 µm absolute)	
	for longer life		$\beta_{10} \geq 75$ (10 µm absolute)				$\beta_{10} \geq 75$ (10 µm absolute)	

¹⁾ With version -...P at 210 bar pilot or operating pressure, with versions -...G, S and H at 140 bar pilot or operating pressure, fluid viscosity of 32 mm²/s and fluid temperature of 40°C.

²⁾ For long life wear protection of metering lands

For additional technical informations, such as dimensions, ordering information etc. see the catalogues.

3. Installation

3.1 General Information

- 3.1.1 Compare model number and valve type with information from the hydraulic schematic or bill of material.
- 3.1.2 The valve can be mounted in any direction, fixed or movable.
- 3.1.3 Check mounting surface for planeness (0,02 mm for 100 mm) and surface roughness (Ra < 1 µm)
- 3.1.4 Pay attention to cleanliness of mounting surface and surroundings when installing the valve.
- 3.1.5 Use lint-free tissue to clean!
- 3.1.6 Before installation, remove protection plate from the valve and keep it for later repair.
- 3.1.7 Pay attention to correct position of ports and location of o-rings during installation.
- 3.1.8 Use socket head bolts according to DIN EN ISO 4762 (hitherto DIN 912) for mounting, strength class 10.9, and tighten them diagonally changing according to table 1. Torque tolerance +/- 10 %.

Series	Mounting pattern ISO 4401	Bolts to DIN 912-10.9	Qty. reqrd.	Torque [Nm]
D661-...G	05-05-0-94	M6 x 60	4	13
D661-...S	05-05-0-94	M6 x 55	4	13
D661-...H	05-05-0-94	M6 x 55	4	13
D661-...P...A/B	05-05-0-94	M6 x 60	4	13
D661-...P...F/G	05-05-0-94	M6 x 55	4	13

Table 1

3.2 Internal/external pilot connection

- 3.2.1 Conversion for operation with internal or external pilot connection.
The pilot connection mode as shipped is indicated by the respective code letter of the type designation on the nameplate.



With the 5-way version, where the T and T₂ ports are interchanged with the P port, pilot supply port X and return port Y must be connected externally.

3.2.2 Conversion instruction for Servovalves D661-...G and Proportional valves D661-...P...A/B

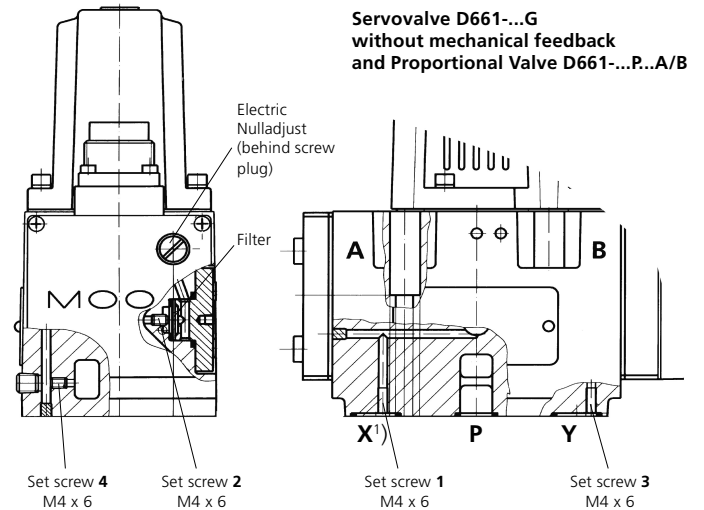

¹⁾ Check for sufficient length (100 mm) of mounting surface!

Pilot flow	Set screw M4 x 6	
Supply	bore 1	bore 2
Internal P	closed	open
External X	open	closed
Pilot flow	Set screw M4 x 6	
Return	bore 3	bore 4
Internal T	closed	open
External Y	open	closed

3.2.3 Conversion instruction for Servovalves D661-...S, H and P...F/G

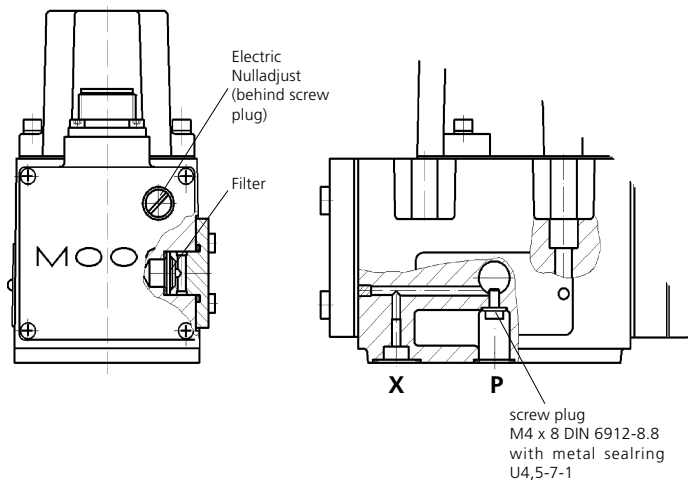

Pilot flow	screw plug
supply	in port
Internal P	X
External X	P

3.3 Electronics information

3.3.1 Valve connectors

Possible connectors

number of pins	supply voltage	
	± 15 VDC	24 VDC
6 +PE	X	X
11 + PE	–	X
11 + 1 (PE) Bayonet	X	–
6 (old, without PE)	X	–
12 (old, without PE) Bayonet	X	–



Please note information regarding input signals on the nameplate!

3.3.2 Valve electronics with supply voltage ± 15 VDC and 6+PE pole connector

3.3.2.1 Command input

Command signal 0 to ±10 V

The spool stroke of the valve is proportional to $(U_D - U_E)$. 100% valve opening P ▶ A and B ▶ T is achieved at $(U_D - U_E) = +10$ V. At 0 V command the spool is in centred position. The input stage is a differential amplifier. If only one command signal is available, pin D or E is connected to signal ground ⊥ (pin C) according to the required operating direction (to be done at the mating connector).

Command signal 0 to ±10 mA

The spool stroke of the valve is proportional to $(I_D - I_E)$. 100% valve opening P ▶ A and B ▶ T is achieved at $(I_D - I_E) = +10$ mA. At 0 mA command the spool is in centred position. Either pin D or E is used according to the required operating direction. The unused pin is left open (not connected at the mating connector). The input pins D and E are inverting.

3.3.2.2 Monitoring output

Actual value 0 to ±10 V

The actual spool position value can be measured at pin F. This signal can be used for monitoring and fault detection purposes.

The spool stroke range corresponds to ±10 V. +10 V corresponds to 100% valve opening P ▶ A and B ▶ T.

Actual value 0 to ±10 mA

The actual spool position value can be measured at pin F. This signal can be used for monitoring and fault detection purposes.

The spool stroke range corresponds to ±10 mA. +10 mA corresponds to 100% valve opening P ▶ A and B ▶ T.

General requirements

- Supply ± 15 VDC ± 3%. Ripple < 50 mV_{pp}. Current consumption max. ± 250 mA
- All signal lines, also those of external transducers, shielded
- Shielding connected radially to ⊥ (0V), power supply side, and connected to the mating connector housing (EMC)
- EMC: Meets the requirements of EN 55011/03.91 class B, EN 50081-1/01.92, and EN 50082-2/03.95, performance criterion class A
- Protective grounding lead ≥ 0,75mm²
- Note: When making electric connections to the valve (shield, protective grounding) appropriate measures must be taken to ensure that locally different earth potentials do not result in excessive ground currents. See also MOOG Application Note AM 353 E.

3.3.2.3 Connector wiring - type code letter S (see sticker on the electronics housing)

Valves with 6+PE pole connector to DIN 43563 and mating connector (metal shell) with leading protective ground connection (⊥)

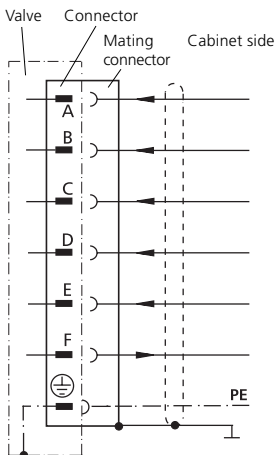

Function	Voltage command	Current command ¹⁾
Supply	+ 15 VDC ± 3 %, ripple < 50 mV _{pp}	
Supply	– 15 VDC ± 3 %, ripple < 50 mV _{pp}	
Supply / signal ground	⊥ (0V)	
Input rated command	0 to ± 10 V	0 to ± 10 mA
Valve flow	Input resistance 100 kΩ	load resistance 400 Ω
Input inverted rated command	0 to ± 10 V	0 to ± 10 mA
Valve flow	Input resistance 100 kΩ	load resistance 400 Ω
Output actual value	0 to ± 10 V	0 to ± 10 mA
Spool position	Output resistance 10 kΩ	load resistance max. 500 Ω
Protective grounding		

¹⁾ Valves having code letter X at position 10 of type designation: Command signal 10 mA between pins D and E (differentially, internal resistance 1 kΩ).

3.3.3 Valve electronics with supply voltage ± 15 VDC and 11+1 pole bayonet connector

Alternate connector for certain valve models

3.3.3.1 Command input

Command signal 0 to ±10 V

The spool stroke of the valve is proportional to $(U_D - U_E)$. 100% valve opening P → A and B → T is achieved at $(U_D - U_E) = +10 V$. At 0 V command the spool is in centred position. The input stage is a differential amplifier. If only one command signal is available, pin D or E is connected to signal ground ⊥ (pin C) according to the required operating direction (to be done at the mating connector).

Command signal 0 to ±10 mA

The spool stroke of the valve is proportional to $(I_D - I_E)$. 100% valve opening P → A and B → T is achieved at $(I_D - I_E) = +10 mA$. At 0 mA command the spool is in centred position. Either pin D or E is used according to the required operating direction. The unused pin is left open (not connected at the mating connector). The input pins D and E are inverting.

Command signal 4 to 20 mA

The spool stroke of the valve is proportional $(I_D - 12 mA)$. 100% valve opening P → A and B → T at $I_D = 20 mA$. At 12mA command the spool is in centred position. The unused Pin E is left open (not connected in the mating connector).

3.3.3.2 Monitoring output

The actual spool position value can be measured at pin F. This signal can be used for monitoring and fault detection purposes.

Command signal 0 to ±10 V

The spool stroke range corresponds to ±10 V. +10 V corresponds to 100% valve opening P → A and B → T.

Command signal 0 to ±10 mA

The spool stroke range corresponds to ±10 mA. +10 mA corresponds to 100% valve opening P → A and B → T.

Command signal 4 to 20 mA

The spool stroke range corresponds to 4 to 20 mA. 20 mA corresponds to 100% valve opening P → A and B → T.



Please note "General requirements" on page 8.

3.3.3.3 Connector wiring - type code letter **V** (see sticker on the electronics housing)

Valves with 11+1 pole bayonet connector to MIL C-26482-14-12 with leading protective grounding connection (K)
 Mating connector: metal shell, Order-No.: B97027 012.

Function	Voltage command	Current command	Current command
Supply	+ 15 VDC ± 3 %, ripple < 50 mV _{pp}		
Supply	+ 15 VDC ± 3 %, ripple < 50 mV _{pp}		
Supply / signal ground	⊥ (0V)		
Input rated command Valve flow	0 to ± 10 V Input resistance 100 kΩ	0 to ± 10 mA Load resistance 400 Ω	4 to 20 mA Load resistance 200 Ω
Input invert. rated command Valve flow	0 to ± 10 V Input resistance 100 kΩ	0 to ± 10 mA Load resistance 400 Ω	not used
Output actual value Spool position	0 to ± 10 V Output resistance 10 kΩ	0 to ± 10 mA Load resistance max. 500 Ω	4 to 20 mA Load resistance max. 500 Ω
Monitoring output of internal position controller			
not used			
not used			
Protective grounding	leading pin of valve connector		
Relay output	24 VDC, max. 0,5 A. For inductive loads a corresponding commutating diode is necessary. The relais contact deenergizes and the pilot stage is disconnected when a supply voltage becomes less than 12 V (thus also in case of cable break). The spool then moves to the determind position without electric supply. Cable break of the ⊥ - wire is not monitored.		

3.3.4 Valve electronics with supply voltage ± 15 VDC and 6 pole connector (without protective grounding)

3.3.4.1 Command input

Command signal 0 to ± 10 V

The spool stroke of the valve is proportional to $(U_D - U_E)$. 100% valve opening P \blacktriangleright A and B \blacktriangleright T is achieved at $(U_D - U_E) = +10$ V. At 0 V command the spool is in centred position. The input stage is a differential amplifier. If only one command signal is available, pin D or E is connected to signal ground \perp (pin C) according to the required operating direction (to be done at the mating connector).

Command signal 0 to ± 10 mA

The spool stroke of the valve is proportional to $(I_D - I_E)$. 100% valve opening P \blacktriangleright A and B \blacktriangleright T is achieved at $(I_D - I_E) = +10$ mA. At 0 mA command the spool is in centred position. Either pin D or E is used according to the required operating direction. The unused pin is left open (not connected at the mating connector). The input pins D and E are inverting.

Command signal 4 to 20 mA

The spool stroke of the valve is proportional $(I_D - 12$ mA). 100% valve opening P \blacktriangleright A and B \blacktriangleright T at $I_D = 20$ mA. At 12mA command the spool is in centred position. The unused Pin E is left open (not connected in the mating connector).

3.3.4.2 Monitoring output

The actual spool position value can be measured at pin F. This signal can be used for monitoring and fault detection purposes.

Command signal 0 to ± 10 V

The spool stroke range corresponds to ± 10 V. +10 V corresponds to 100% valve opening P \blacktriangleright A and B \blacktriangleright T.

Command signal 0 to ± 10 mA

The spool stroke range corresponds to ± 10 mA. +10 mA corresponds to 100% valve opening P \blacktriangleright A and B \blacktriangleright T.

Command signal 4 to 20 mA

The spool stroke range corresponds to 4 to 20 mA. 20 mA corresponds to 100% valve opening P \blacktriangleright A and B \blacktriangleright T.

General requirements

- Supply ± 15 VDC $\pm 3\%$. Ripple < 50 mV_{pp}. Current consumption max. ± 250 mA
- All signal lines, also those of external transducers, shielded
- Shielding connected radially to \perp (0V)
- Note: When making electric connections to the valve (shield, protective grounding) appropriate measures must be taken to ensure that locally different earth potentials do not result in excessive ground currents.

3.3.4.3 Connector wiring - type code letter 6

Valves with 6 pole connector to MIL C-5015/14S-6. Mating connector: metal shell, Order-No.: A26201 004

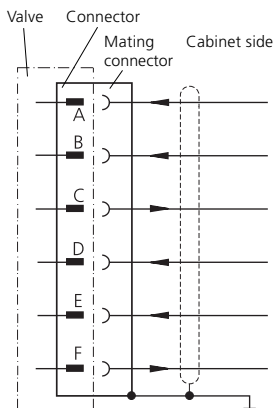

Function	Voltage command 0 to ± 10 V	Current command 0 to ± 10 mA	Current command 4 to 20 mA
Supply	+ 15 VDC $\pm 3\%$, ripple < 50 mV _{pp}		
Supply	- 15 VDC $\pm 3\%$, ripple < 50 mV _{pp}		
Supply / signal ground	\perp (0V)		
Input rated command	0 to ± 10 V	0 to ± 10 mA	4 to 20 mA
Valve flow	Input resistance 100 k Ω	Load resistance 400 Ω	Load resistance 200 Ω
Input invert. rated command	0 to ± 10 V	0 to ± 10 mA	not used
Valve flow	Input resistance 100 k Ω	Load resistance 400 Ω	
Output actual value	0 to ± 10 V	0 to ± 10 mA	4 to 20 mA
Spool position	Output resistance 10 k Ω	Load resistance max. 500 Ω	Load resistance max. 500 Ω

3.3.5 Valve electronics with supply voltage ± 15 VDC and 12 pole bayonet connector (without protective grounding)

3.3.5.1 Command input

Command signal 0 to ±10 V

The spool stroke of the valve is proportional to $(U_D - U_E)$. 100% valve opening P → A and B → T is achieved at $(U_D - U_E) = +10$ V. At 0 V command the spool is in centred position. The input stage is a differential amplifier. If only one command signal is available, pin D or E is connected to signal ground ⊥ (pin C) according to the required operating direction (to be done at the mating connector).

Command signal 0 to ±10 mA

The spool stroke of the valve is proportional to $(I_D - I_E)$. 100% valve opening P → A and B → T is achieved at $(I_D - I_E) = +10$ mA. At 0 mA command the spool is in centred position. Either pin D or E is used according to the required operating direction. The unused pin is left open (not connected at the mating connector). The input pins D and E are inverting.

Command signal 4 to 20 mA

The spool stroke of the valve is proportional $(I_D - 12$ mA). 100% valve opening P → A and B → T at $I_D = 20$ mA. At 12mA command the spool is in centred position. The unused Pin E is left open (not connected in the mating connector).

3.3.5.2 Monitoring output

The actual spool position value can be measured at pin F. This signal can be used for monitoring and fault detection purposes.

Command signal 0 to ±10 V

The spool stroke range corresponds to ±10 V. +10 V corresponds to 100% valve opening P → A and B → T.

Command signal 0 to ±10 mA

The spool stroke range corresponds to ±10 mA. +10 mA corresponds to 100% valve opening P → A and B → T.

Command signal 4 to 20 mA

The spool stroke range corresponds to 4 to 20 mA. 20 mA corresponds to 100% valve opening P → A and B → T.



Please note "General requirements" on page 10.

3.3.5.3 Connector wiring - type code letter 0

Valves with 12 pole bayonet connector to MIL C-26482/14-12. Mating connector: metal shell, Order-No.: B97027 012.

Function	Voltage command 0 to ± 10 V	Current command 0 to ± 10 mA	Current command 4 to 20 mA
Supply	+ 15 VDC ± 3 %, ripple < 50 mV _{pp}		
Supply	- 15 VDC ± 3 %, ripple < 50 mV _{pp}		
Supply / signal ground	⊥ (0V)		
Input rated command Valve flow	0 to ± 10 V Input resistance 100 kΩ	0 to ± 10 mA Load resistance 400 Ω	4 to 20 mA Load resistance 200 Ω
Input invert. rated command Valve flow	0 to ± 10 V Input resistance 100 kΩ	0 to ± 10 mA Load resistance 400 Ω	not used
Output actual value Spool position	0 to ± 10 V Output resistance 10 kΩ	0 to ± 10 mA Load resistance max. 500 Ω	4 to 20 mA Load resistance max. 500 Ω
Monitoring output of internal position controller	0 to ± 12 V Output resistance 10 kW		
not used			
not used			
not used			
Relay output	24 VDC, max. 0,5 A. For inductive loads a corresponding commutating diode is necessary. The relays contact deenergizes and the pilot stage is disconnected when a supply voltage becomes less than 12 V (thus also in case of cable break). The spool then moves to the determined position without electric supply. Cable break of the ⊥ - wire is not monitored.		

3.3.6 Valve electronics with supply voltage 24 Volt and 6+PE - pole connector

3.3.6.1 Command input

Command signal 0 to ± 10 V

The spool stroke of the valve is proportional to $(U_D - U_E)$. 100% valve opening P \blacktriangleright A and B \blacktriangleright T is achieved at $(U_D - U_E) = +10$ V. At 0 V command the spool is in centred position. The input stage is a differential amplifier. If only one command signal is available, pin D or E is connected to signal ground \perp (pin B) according to the required operating direction (to be done at the mating connector).

Command signal 0 to ± 10 mA

The spool stroke of the valve is proportional to $(I_D - I_E)$. 100% valve opening P \blacktriangleright A and B \blacktriangleright T is achieved at $(I_D - I_E) = +10$ mA. At 0 mA command the spool is in centred position. Either pin D or E is used according to the required operating direction. The unused pin is left open (not connected at the mating connector). The input pins D and E are inverting.

3.3.6.1 Monitoring output

Actual value $+2,5$ to $+13,5$ V

Valves with voltage and current command input

The actual spool position value can be measured at pin F (see diagram below). This signal can be used for monitoring and fault detection purposes.

The spool stroke range corresponds to $+2,5$ to $+13,5$ V. The centred position is at $+8$ V. $+13,5$ V corresponds to 100% valve opening P \blacktriangleright A and B \blacktriangleright T.

General requirements

- Supply 24 VDC, min. 19 VDC, max. 32 VDC. Current consumption max. 300 mA
- All signal lines, also those of external transducers, shielded
- Shielding connected radially to \perp (0V), power supply side, and connected to the mating connector housing (EMC)
- EMC:** Meets the requirements of EN 55011/03.91 class B, EN 50081-1/01.92, and EN 50082-2/03.95, perf. crit. class A
- Protective grounding lead $\geq 0,75\text{mm}^2$
- Note: When making electric connections to the valve (shield, protective grounding) appropriate measures must be taken to ensure that locally different earth potentials do not result in excessive ground currents. See also MOOG Application Note AM 353 E.

Circuit diagram for measurement of actual value U_F (position of main spool) for valves with 6+PE pole connector

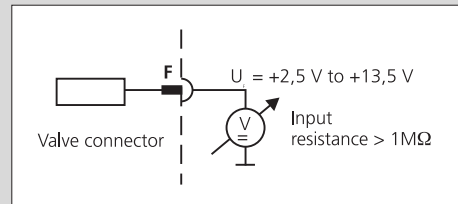

3.3.6.3 Connector wiring - type code letter **S** (see sticker on the electronics housing)

Valves with 6+PE pole connector to DIN 43 563 and mating connector (metal shell) with leading protective ground connection (\perp)

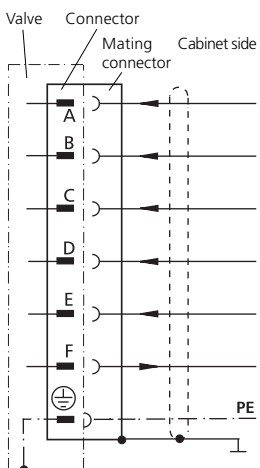

Function	Voltage command		Current command
Supply	24 VDC (min. 19 VDC, max. 32 VDC)		I_{max} : 300 mA
Supply / signal ground	\perp (0 V)		
Enabled ¹⁾ Not enabled	$U_{C-B} > +8,5$ VDC $U_{C-B} < +6,5$ VDC		$I_e = 1,2$ mA at 24 VDC
Input rated command (differential)	U_{D-E} : 0 to ± 10 V R_e : 10 k Ω	U_{D-B} and U_{E-B} : max.: -15 V max.: $+24$ V	Input command referenced to \perp $I_{D,E}$: 0 to ± 10 mA (load resistance 200 Ω) Input command (invert.) I_{E-D} : 0 to ± 10 mA
Output actual value	U_{F-B} : $+2,5$ to $+13,5$ V. At $+8$ V spool in centered position R_a : approx. 15 k Ω		
Protective grounding			

¹⁾ With enable signal $< +6,5$ V the spool moves into the position adjusted for $+8$ V command signal.

3.3.7 Valve electronics with supply voltage 24 Volt and 11+PE - pole connector

3.3.7.1 Command input

Command signal 0 to ±10 V

The spool stroke of the valve is proportional to $(U_D - U_E)$. 100% valve opening P \blacktriangleright A and B \blacktriangleright T is achieved at $(U_D - U_E) = +10$ V. At 0 V command the spool is in centred position. The input stage is a differential amplifier. If only one command signal is available, pin D or E is connected to signal ground \perp (pin B) according to the required operating direction (to be done at the mating connector).

Command signal 0 to ±10 mA

The spool stroke of the valve is proportional to $(I_D - I_E)$. 100% valve opening P \blacktriangleright A and B \blacktriangleright T is achieved at $(I_D - I_E) = +10$ mA. At 0 mA command the spool is in centred position. Either pin D or E is used according to the required operating direction. The unused pin is left open (not connected at the mating connector). The input pins D and E are inverting.

3.3.7.2 Monitoring output

Actual value 0 to ±10 V

Valves with voltage and current command input

The actual value, i. e. the spool position, can be measured between pins 6 and 7. This signal can be used for monitoring and fault detection purposes. The signal can only be measured using a weighted differential amplifier (see diagram below) or a voltmeter with an input impedance greater than 1M Ω . The spool stroke range corresponds to ± 10 V. The centred position is at 0 V. +10 V corresponds to 100% valve opening P \blacktriangleright A and B \blacktriangleright T. If the actual value shall be used with a machine control system the differential input circuit must be applied. Another option is to use the afore mentioned circuit for the 6+PE pole connector. Pin 6 according to DIN 43 651 corresponds to pin F according to DIN 43 563 (see diagram page 12).



Please note "General requirements on page 12."

Circuit diagram for measurement of actual value $U_{6,7}$ (position of main spool) for valves with 11+PE pole connector

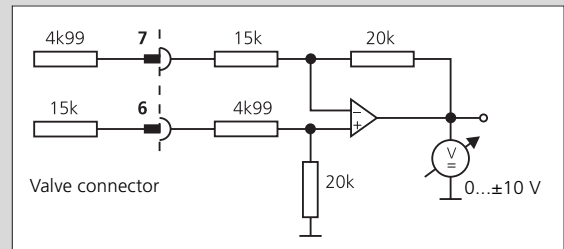
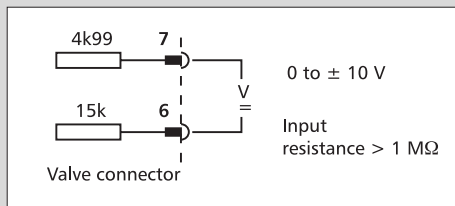

3.3.7.3 Connector wiring - type code letter **E** (see sticker on the electronics housing)

Valves with 11+PE pole connector to DIN 43 651 and mating connector (metal shell) with leading protective ground connection (\perp)			
Function	Voltage command		Current command
Supply	24 VDC (min. 19 VDC, max. 32 VDC)		I_{max} : 300 mA
Supply / signal ground	\perp (0 V)		
Enabled ¹⁾ Not enabled	$U_{3,2} > +8,5$ VDC $U_{3,2} < +6,5$ VDC		$I_e = 1,2$ mA at 24 VDC
Input rated command (differential)	U_{4-5} : 0 to ± 10 V R_e : 10 k Ω	U_{4-2} and U_{5-2} : max.: -15 V max.: +24 V	Input command referenced to \perp I_{4-5} : 0 to ± 10 mA (load resistance 200 Ω) Input command (invert.) ref. to \perp I_{5-4} : 0 to ± 10 mA
Output actual value (differential)	U_{6-7} : 0 to ± 10 V R_a : approx. 20 K Ω		
Enable and Supply acknowledged	$U_{8-2} > +8,5$ VDC: ok $U_{8-2} < +6,5$ VDC: not ok		Output I_{max} : 20 mA
not used	Note: With valve models D661-27XX and D661-29XX supply voltage is at pin 9 and signal ground at pin 10.		
not used	Pins 1 and 2 are not used.		
Position error	$U_{11-2} > +8,5$ VDC: <30 % $U_{11-2} < +6,5$ VDC: >30 %		Output I_{max} : 20 mA
Protective grounding			

¹⁾ With enable signal < +6,5 V the spool moves into the position adjusted for 0 V command signal.

3.4 Electric connection

The specified mating connectors for the valves have **crimp contacts of size 16**. If crimp tools are not available the contacts can also be soldered. The bayonet connector with 11+1 pin can only be soldered.

3.4.1 Instruction for crimping

If you order the connector the necessary socket contacts are enclosed in the delivery bag of the mating connector supplied with the valve.

Special tools are required for preparing cables and connectors. (These tools are listed in chapter 8.1 "Tools").

Pay attention to the wiring instructions, which are to be found in this assembly instruction. The complete instructions can be received from MOOG together with the tools set.

3.4.2 Baring wires

Bare cables professionally to a length of 6,5 mm. Don't damage conductor or squeeze insulation.

3.4.3 Wiring contacts

Connect contacts only with prescribed tools (see 8.1 and assembly instructions). After crimping check whether

- wire can be seen through the inspection hole in the contact
- none of the contacts is bent or damaged
- no strand is outside the termination hole
- a proper crimp termination with eight crimp indents has been performed.

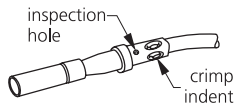

3.4.4 Assembling contacts

After wiring the contacts, the leads have to be pulled through all accessories used, such as grommet, ferrule, endbell and cable clamp. Make sure that leads are inserted through the appropriate cavity of grommet. In order to ease insertion of leads, the contacts have to be dipped in Isopropyl.

3.4.5 Inserting contacts

Dip contacts in Isopropyl and insert them with prescribed tool (see 8.1 and assembly instructions) through the grommet with constant pressure (into the insulator) until it snaps into its position. Insert contacts according to marking on the insulator.

Also insert unwired contacts in order to guarantee proper sealing.

3.4.6 Removing contacts

All accessories are removed in reverse direction as described in chapter 3.2.4.3 Remove contacts with prescribed tool according to assembly instructions.

3.4.7 Shielding

When fixing a shielding braid to connector with DZ-adaptor

- Loosen lock nut (5). Slide heat shrink component (6) and lock nut (5) over cable(8).

- Push shielding braid (7) onto endbell (3).

- Fix shielding braid (7) into rounded groove by means of baling wire (4).

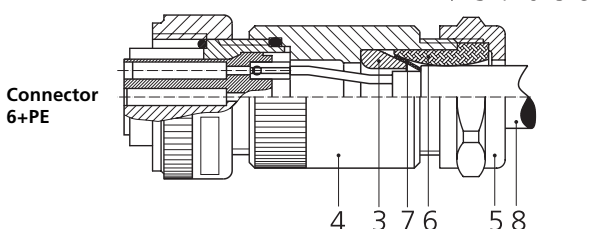
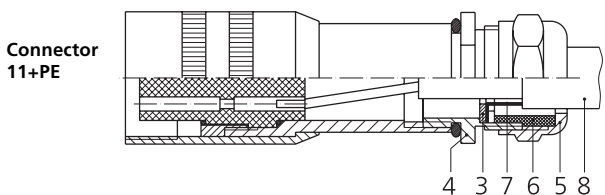

4. Setting up

This information is valid for new installations to be put into operation as well as for repair cases.

4.1 Filling the hydraulic system



New oil is never clean. Therefore the system should generally be filled by using a filling filter. This fine mesh filter should at least comply with the following requirement: $\beta_{10} \geq 75$ (10 μm absolute).

4.2 Flushing the hydraulic system



Before the hydraulic system is put into operation for the first time (also after modifications) it has to be flushed carefully according to the instructions of the manufacturer of the plant / machine.

4.2.1 Before flushing suitable flushing elements have to be inserted in the pressure filters instead of the high pressure elements.

4.2.2 Before flushing the operational temperature of the hydraulic system should be achieved. Observe temperature!

4.2.3 A flushing plate or, if the system allows, a directional valve should be mounted in place of the MOOG proportional valve. The P- and T-connections are flushed through the flushing plate. The user A- and B- connections can also be flushed by the directional valve.

Attention, the directional valve can lead to unpermissible movements in the load (i.e. with parallel drives), which may result in damage of the plant / machine. Instructions of the manufacturer have to be strictly observed.

Minimum flushing time t can be calculated as follows:

$$t = \frac{V}{Q} \cdot 5$$

V = content of reservoir [liter]
 Q = flow rate of the pump [l/min]
 t = flushing time [hours]

4.2.4 The flushing process can be considered completed when a system cleanliness of 15/12 according ISO 4406 or 6 according NAS 1638 or better is achieved. A long life of the metering lands of the proportional valve can be expected for this cleanliness class.

4.2.5 Replace flushing elements in the pressure filters by suitable high pressure elements after flushing. Install MOOG proportional valve instead of flushing plate or directional valve.



4.3 Setting up

4.3.1 Set up machine/plant according to the operation instructions of the manufacturer after the valves have been installed. Vent hydraulic system!



4.3.2 The safety instructions of the machine/plant manufacturer must be observed. Especially the safety requirements for machines like injection moulding machines (EN 201), blow moulding machines (EN 422) and die casting machines (EN 869), to name a few, are important.

4.3.3 Observe oil temperature.

4.3.4 Check hydraulic system for external leakage!

4.4 Nulladjustment

The hydraulic null of the valve is preset at the factory with a tolerance of $\pm 2\%$ of rated signal. If necessary this null can be readjusted by the user of the valve.

4.4.1 Observe operating instruction for the **machine/plant**. Valves with +4 to +20 mA command signal: Do not adjust valve null! Contact **machine/plant manufacturer**.



4.4.2 **Procedure:** Remove the command signal to the valve only by disconnecting command signal lead at the cabinet.



Do not remove valve mating connector!

Remove cover screw on electronics housing to access the null adjust potentiometer. Use a small screwdriver (blade width 2.5 mm) to turn the potentiometer screw either clockwise or counterclockwise. Usually it will not be necessary to turn the screw more than 2 turns in either direction (± 1 turn is equivalent to $\pm 15\%$ null shift).

4.4.3 While adjusting watch the actuator (motor) motion to find the null position. With overlapped valves turn the nulladjust screw carefully in both directions to just start motion and then back into deadzone midposition between those two screw positions.

4.4.4 After proper null adjustment reconnect the command signal lead and apply protective cover screw again.

5. Maintenance



Besides regular visual inspection for external leakage and filter replacement, maintenance work at the valves D661 Series is not required.

Explosionproof valves D661K... must not be opened by the customer! Unauthorized opening will invalidate the explosionproof approval! Return failed valve to the factory.

MOOG valves can only be repaired at MOOG Service Centres (for addresses see backpage of this maintenance instruction).

5.1 Filter replacement

The built-in filter disk protects orifices and nozzles against coarse contaminants. With severe contamination the valve response will be slowed down.



Replace filter!

Cleaning is useless and may be **dangerous!**



Before starting to work on the valve clean the external surface around the filter cover!



Attention: The filter disk (21) is flown from inside to the outside. After removal of the cover (20) any contamination particles are at the inside of the disk (21) and therefore cannot be seen from outside.

5.1.1 Remove four internal hex bolts (38) using Allan wrench (SW3). Remove cover (20). Remove the filter disk (21) now accessible by using a scribe or a fine screwdriver as extraction tool.

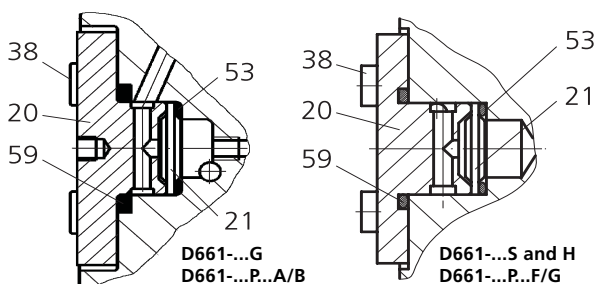

5.1.2 Check o-rings (59) and (53) for damage. Replace if necessary.

5.1.3 Insert o-ring (53) first. Then insert the new filter disk (21)

such that the side with the notch at the rim points outward. Mount o-ring (59) on the cover (20) using clean grease and mount cover to the valve body. The M4-bolts should be torqued to 4,1 Nm, the M5-bolts to 8,5 Nm (38).

5.1.4 Check valve for external leakage after pressurizing it.

6. Malfunctions, Causes and Elimination

For trouble shooting D661 - Series valves use of MOOG Valve Tester Model M040-120 is suggested. See Operation Instruction "MOOG Valve Tester"

6.1 Leakage at the mounting surface of the valve

- Have all seals been installed at ports A, B, P, T, (T₂), Y and X and are they ok?
- Have the mounting bolts been tightened correctly?



Pay attention to the required torque! Tighten bolts diagonally changing!

6.2 No hydraulic response of the valve

- Check all signals from pin A (1) to pin F (6).
- Is supply voltage present?
- Is electric input signal (command signal) present?
With 24 VDC supply voltage:
- Is the enable signal > +8,5 V an pin C present?
- Check the mating connector for corrosion!
- Is hydraulic pressure present?
- Check pilot supply. Do you need internal or external?
- If external, is pilot pressure present?
- Is the filter disk contaminated?
With failsafe version:
- Does the solenoid of the 2/2-way valve operate properly?

6.3 Instability of the system, plant oscillates

- Check, whether output signal at pin F (6) is following exactly the command signal at pin D (4) or E (5).
If so, the external loop is unstable.
If not, the electronics of the valve may be defective.
- Check filter disk for contamination.

6.4 With zero command signal the load drifts slowly off position (open loop)

- With ± 15 VDC supply:*
- Check for supply voltage at pins A(1) and B(2) being stable and within $\pm 3\%$ of 15 V.
- With both ± 15 VDC and 24 VDC supply:*
- With zero command and at normal operating temperature stop load motion by adjusting nulladjust potentiometer (behind screw plug).

6.4 With hydraulics ON valve goes hardover

(Only with nozzle-flapper pilot stage)



Orifice contaminated (plugged). Send valve to MOOG service center.

7. Declaration of Manufacturer

A Declaration of Manufacturer according to EC machine directive 89/392/EWG, Annex II B, is available for servo and proportional valves D661 Series and will be supplied upon request.

8. Tools, spare parts and accessories

8.1 Tools

For installation, set up, nulladjustment and filter replacement the following tools are required.

8.1.1 Installation of the valve

8.1.1.1 Mounting of the valve requires allan wrench SW 5

8.1.2 Null adjust of the valve at set up.

8.1.2.1 Screwdriver 7 mm to remove the cover screw

8.1.2.2 Screwdriver 2,5 mm for zero setting on internal potentiometer

8.1.3 Filter replacement

8.1.3.1 For removal and mounting of the cover
Allan wrench SW 3

8.1.3.2 For extraction of the filter disk use of a scribe or small screw driver is suggested.

8.1.3.3 For mounting the o-ring on the cover and for inserting o-rings into the valve base clean grease is required.



Standard grease must not be used with valve models having EPDM seals. **Use special grease!**

8.1.4 Assembly of crimp contacts of the connector as per description section 3.4 on page 14

8.1.4.1 All connectors with the exception of the 11+PE connector

Item	Qty.	Description	MOOG Part No.
1	1	Crimp pliers	C21162 001
2	1	Positioner, tool insert for contact sizes 16 und 20	C21163 001
3	1	Installation tool for contact size 16	C21164 001
4	1	Replacement tool for contact size 16	C21165 001

The complete tool set for crimping can be obtained from MOOG by ordering part no. **C21166 001**.

8.1.4.2 11+PE pole connector

Item	Qty.	Description	MOOG Part No.
1	1	Crimp pliers	B97136
2	1	Replacement tool	B97137



The complete tool set for crimping can be obtained from MOOG by ordering part no. **B97138**.

8.2 Spare parts

MOOG Part No.	Description	Only for model	Pos. ¹⁾	Dimensions	Material	Qty.
42082 004	O-ring, ports P, T, A, B, (T ₂)			ID 12,4 x Ø 1,8	FPM Sh 85	5 pcs.
42082 011	O-ring, ports X and Y			ID 15,6 x Ø 1,8	FPM Sh 85	2 pcs.
A67999 200	Replaceable filter disk	D661-P...A/B	21	200 µm nominal		1 pc.
A67999 100	Replaceable filter disk	D661-G, S, H and P...F/G	21	100 µm nominal		1 pc.
A25163 013 015	O-ring, behind filter disk		53	ID 13 x Ø 1,5	FPM Sh 85	1 pc.
B97009 080	O-ring, for filter cover	D661-P...A/B	59	ID 17,1 x Ø 2,6	HNBR	1 pc.
A25163 017 020	O-ring, for filter cover	D661-G, S and H	59	ID 17 x Ø 2	FPM Sh 65	1 pc.
66166 040 006	Allan set screw, ports X and Y	D661-G and P		M4 x 6 DIN 913-45H		2 pcs.
66098 040 006	screw plug, port X	D661-S and H		M4 x 6 DIN 912-8.8		1 pc.
A25528 040	Seal, port X	D661-S and H		ID 4,5 / AD 7		1 pc.

¹⁾ see sketch chapter 5.1, Filter replacement, on page 15

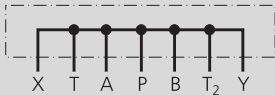
8.3 Accessories (not including in delivery)

MOOG Part No.	Description	Dimensions / Notes	Qty.
	Mating connector, waterproof, protection IP65	for cable mit Litze mind. 0,75 mm ²	
B97007 061	6+PE-pole	DIN 43563 min. Ø 10 mm, max. Ø 12 mm	
B97024 111	11+PE-pole	DIN 43651 min. Ø 10 mm, max. Ø 14 mm	
B97027 012	11+1-pole (Bayonet)	MIL C-26482/14-12 min. Ø 10 mm, max. Ø 14 mm	
A26201 004	6-pole	MIL C-5015/14S-6 min. Ø 10 mm, max. Ø 12 mm	
B97027 012	12-pole (Bayonet)	MIL C-26482/14-12 min. Ø 10 mm, max. Ø 14 mm	
A03665-060-060	Mounting bolts	D661-...G and ...P	4 pcs.
A03665-060-055	Mounting bolts	D661-...H and ...S	4 pcs.
	Mounting manifolds	see special data sheet	
B67728-001	Flushing plate		
B67728-002	Flushing plate		
B67728-003	Flushing plate		

D661

Model-Number



Type designation



Specification status	
-	Series specification
E	Preseries specification
Z	Special specification

Model designation	
	assigned at the factory

Factory identification	

Valve version	
P	Standard spool

Rated flow		
	Q_N [l/min] at $\Delta p_N = 5$ bar per land	Valve version
16	16	P...F/G -
25	25	P...F/G -
30	30	- P...A/B
60	60	P...F/G P...A/B
80	80	- P...A/B

Maximum operating pressure p_p		Pilot valve
B	70 bar. At $p_x \leq 70$ bar (X and Y external) operating pressure in port P, A, B and T up to 350 bar possible.	A/B
F	210 bar. At $p_x \leq 210$ bar (X external) operating pressure in port P, A, B and T up to 350 bar possible.	A/B
H	280 bar. At $p_x \leq 280$ bar (X and Y external) operating pressure in port P, A, B and T up to 350 bar possible.	A/B
K	350 bar (with dropping orifice in filter cover)	A/B, F/G

Main spool type	
A	4-way: ~ critical lap, linear characteristic
D	4-way: 10 % overlap, linear characteristic
P	4-way: P \blacktriangleright A, A \blacktriangleright T: ~ critical lap, curvilinear characteristic P \blacktriangleright B: 60 % overlap, curvilinear characteristic B \blacktriangleright T: 50 % underlap, linear characteristic
U	5-way: P \blacktriangleright A, P \blacktriangleright B, A \blacktriangleright T: ~crit. lap, curvil. character.
Y	4-way: ~ critical lap, curvilinear characteristic
X	Special spool on request

Pilot stage		
	Pilot flow at $p_x = 140$ bar	Pilot pressure p_x
A	ServoJet 1,3	15 – 280
B	ServoJet 2,0	15 – 280
F	Nozzle/Flapper 1,15	15 – 280
G	Nozzle/Flapper 0,65	15 – 280

Electric supply		
0	± 15 VDC	$\pm 3\%$
2	24 VDC	(19 to 32 VDC)

Signals for 100% spool stroke			
	Command	Output	for supply voltage
A	± 10 VDC	± 10 VDC	0 2 (11+PE diff)
B	± 10 mA	± 10 mA	0 —
C	± 10 mA	± 10 VDC	— 2 (11+PE diff)
F	± 10 VDC	+2,5 to +13,5 V, enable	— 2 (6+PE)
G	± 10 mA	+2,5 to +13,5 V, enable	— 2 (6+PE)
T	± 10 VDC	± 10 V deadband comp.	0 2 (11+PE diff)

Valve connector		for supply voltage	
S	6 + PE-pole	DIN 43563	0 2
E	11 + PE-pole	DIN 43651	— 2

Seal material		
N	NBR	Standard
V	FPM	(Viton) optional
	Others on request	

Pilot connections			
	Former code	Supply	Return
4	A, E, J	internal	internal
5	C, F, L	external	internal
6	B, G, K	external	external
7	D, H, M	internal	external

Spool position of main stage without electric or hydraulic supply			
O	undefined	for all valve types	
Mechanical fail-safe version			
	Position	p_p [bar]	p_x extern [bar]
A	P \blacktriangleright B, A \blacktriangleright T	≥ 15	≥ 15
M	Mid position	≥ 15	<1
	undefined	≥ 15	≥ 15
R	Mid position	≥ 15	<1
	P \blacktriangleright B, A \blacktriangleright T	≥ 15	≥ 15
L	Mid position	≥ 15	<1
	P \blacktriangleright A, B \blacktriangleright T	≥ 15	≥ 15
Electrically controlled fail-safe version			
	Position	p_p [bar]	p_x ext SV* VE**
W	Mid position	≥ 15	≥ 15 off on
	Mid position	≥ 15	<1 on on
U	Mid position	≥ 15	≥ 15 off on
	P \blacktriangleright B, A \blacktriangleright T	≥ 15	≥ 15 on off (without electric supply)
V	P \blacktriangleright B, A \blacktriangleright T	≥ 15	≥ 15 off on
	P \blacktriangleright B, A \blacktriangleright T	≥ 15	≥ 15 on off (without electric supply)
P	definiert ~30%	≥ 15	≥ 15 off on (P_x Torquemotor < 2 bar)
	P \blacktriangleright B, A \blacktriangleright T	≥ 15	≥ 15 on off

*SV: Solenoid valve
**VE: Valve electronics

**Preferred configurations are highlighted.
All combinations may not be available.**

**Options may increase price.
Technical changes are reserved.**



Argentina
Australia
Austria
Brazil
China
Finland
France
Germany
India
Ireland
Italy
Japan
Korea

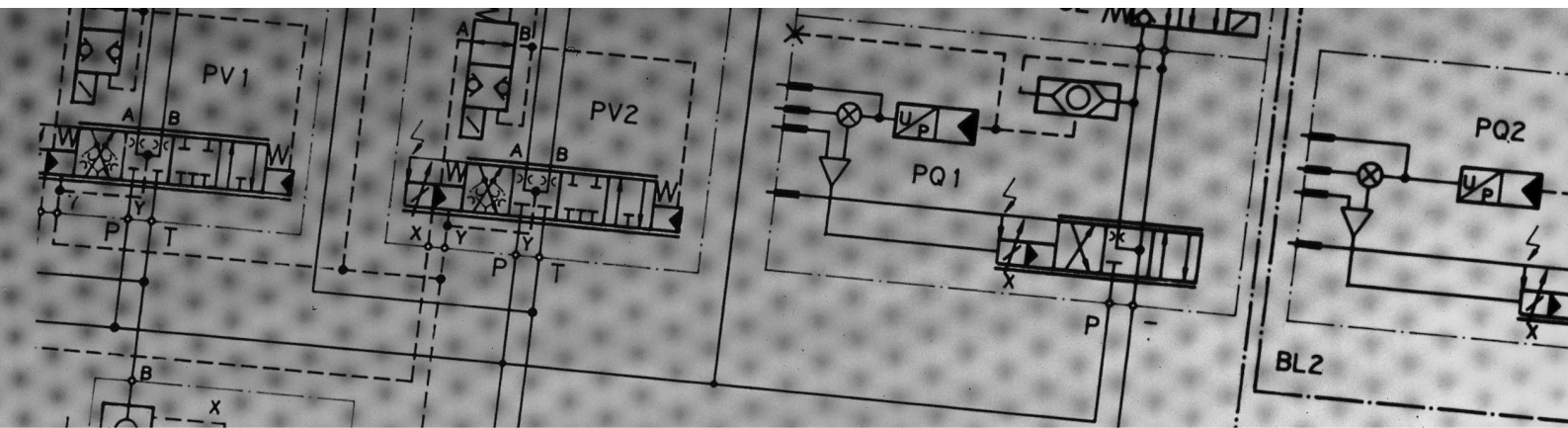

Luxembourg
Norway
Philippines
Russia
Singapore
South Africa
Spain
Sweden
United Kingdom
USA

MOOG

Moog GmbH
Hanns-Klemm-Straße 28
71034 Böblingen (Germany)
Telefon (07031) 622-0
Telefax (07031) 622-191
Our Locations:
www.moog.com/worldwide

CA36197-001 (Version 3.0; 01.01)
Operating Instructions D661