

### Pressure relief valve DBDP06, directly operated, subplate mounting, ISO 4401 Size 03

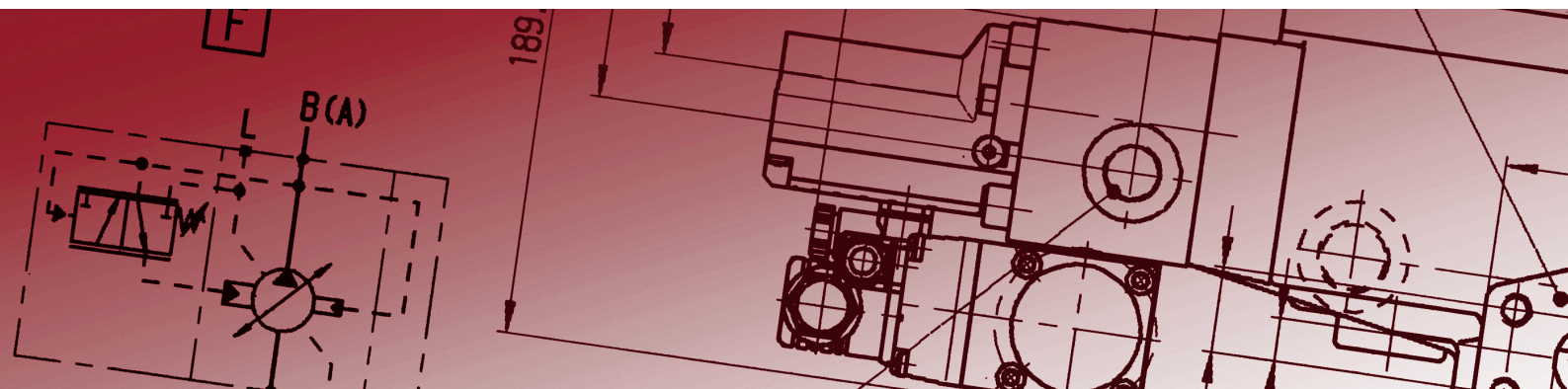
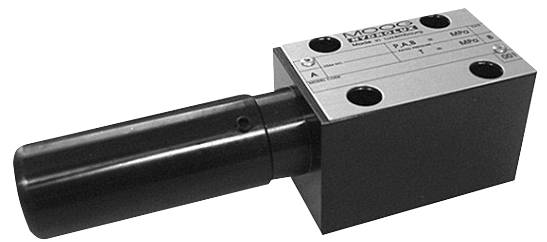

#### DESCRIPTION

Pressure relief valve of series DBDP06 are subplate mounting valves.

They are used both as safety valves avoid unacceptable high pressure as well as for adjusting the required pressure in a hydraulic system.

#### SYMBOL

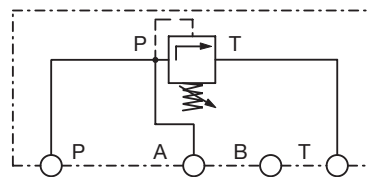

## SPECIFICATIONS

General Data	Value	Unit	Specifications
Designation	–	–	Pressure relief valve
Mode of construction	–	–	Seat valve
Mounting style	–	–	Subplate mounting
Norminal size	–	–	Size 03 (ISO 4401-AB-03-4-A)
Dimensions	–	mm	see on page 3
Mounting position	–	–	any
Flow direction	–	–	P, A => T
Ambient temperature range	min. max.	°C °C	- 25 + 60
Weight	–	kg	1.4
Hydraulic data			
Working pressure P, A and T	min. max.	bar bar	0 350
Fluid temperature range	min. max.	°C °C	- 25 + 80
Viscosity range	min. max.	mm <sup>2</sup> · s <sup>-1</sup> (cSt) mm <sup>2</sup> · s <sup>-1</sup> (cSt)	2.8 380
Operational viscosity	v	mm <sup>2</sup> · s <sup>-1</sup> (cSt)	35
Nominal flow	Qn	l/min	6

## TYPICAL CHARACTERISTIC CURVES

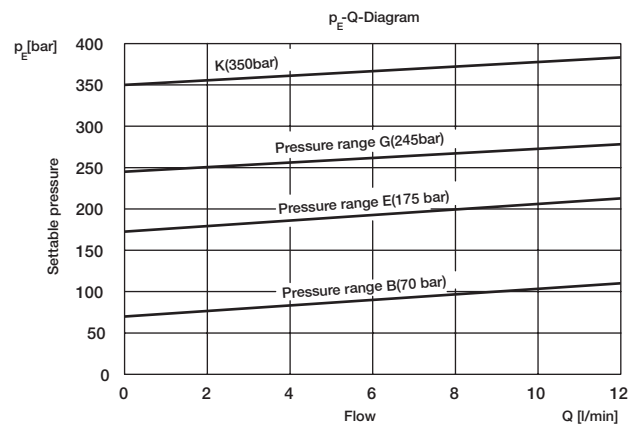
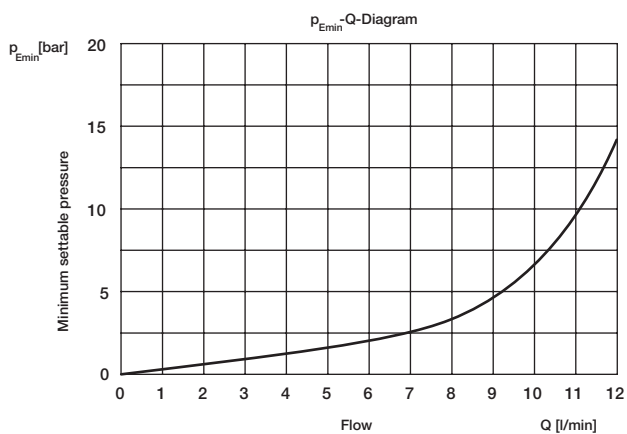

**ORDERING INFORMATION**

	-	D	BD	P	06	A	4	PAT			/	
--	---	---	----	---	----	---	---	-----	--	--	---	--

Seals	
	FPM/FKM (Standard)
M	FPM/FKM + PUR
N	NBR

Valve type	
D	Pressure valve

Valve function	
BD	Relief valve, directly operated

Mounting	
P	Subplate mounting

Size	
06	NG06 (ISO 4401, Größe 3)

Serial number	
---------------	--

MA	adjustment A-Side
MB	adjustment B-Side

Pressure range	
B	70 bar
E	175 bar
G	245 bar
K	350 bar

Adjustment type	
2	Socket screw with counternut
8	Socket screw with counternut, cap and sealed

Function	
PAT	Pressure relief from P, A → T

Series	
4	Connection as per DIN 24340

**DIMENSIONS ADJUSTMENT A-SIDE**

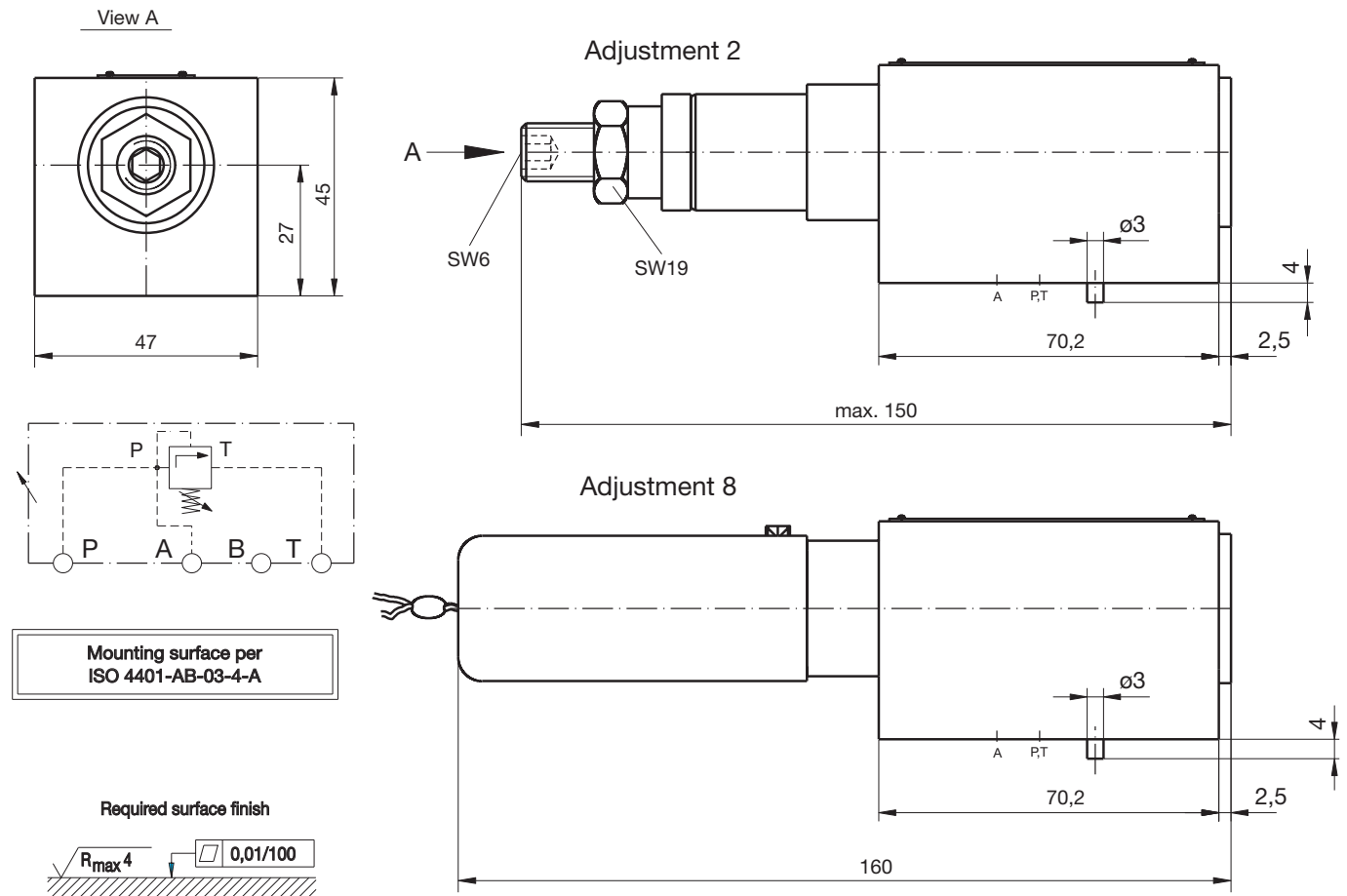

**DIMENSIONS ADJUSTMENT B-SIDE**

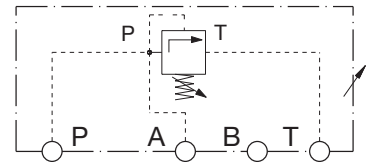
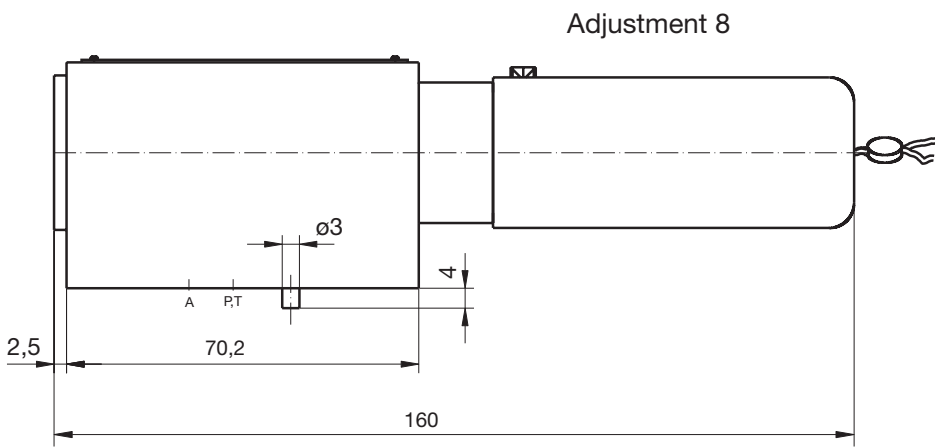
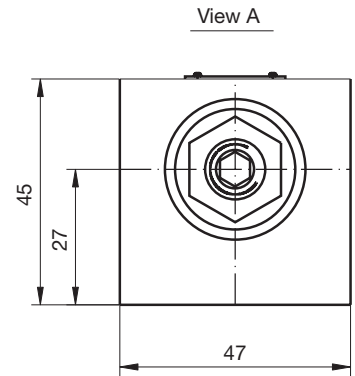
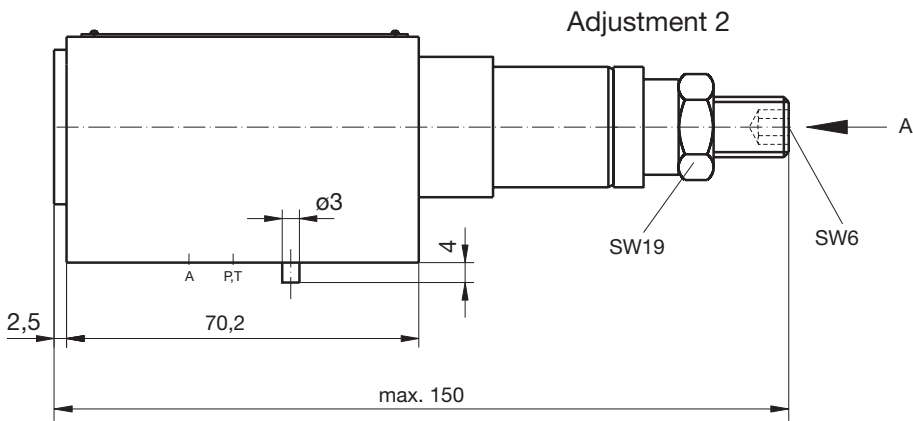

Mounting surface per  
ISO 4401-AB-03-4-A

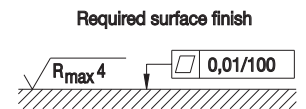

**SPARE PARTS**

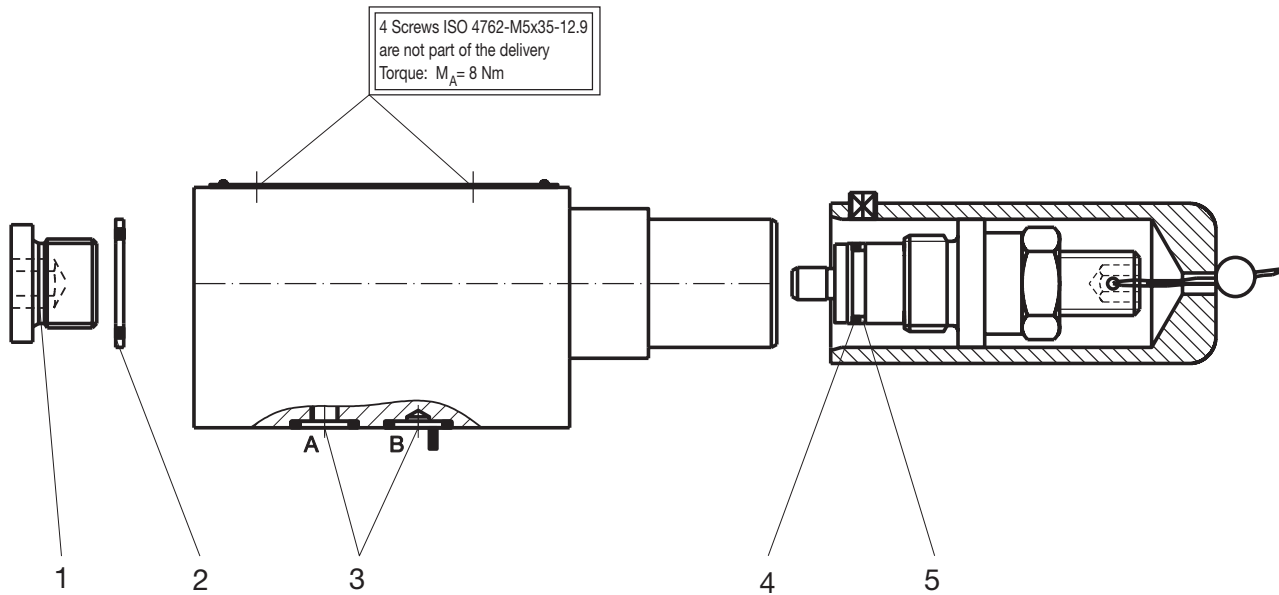

Pos.	Designation	Order Number
	Seal Kit	XEB13972-000-00
1	Plug	X786-33502
2	Usit Ring	X783-12415
3	O-Ring	X980-02012
4	O-Ring	X980-02013
5	Back-Up Ring	X780-00074

**Order example:** O-Ring Pos.3 => Order Number: X980-02012

**STANDARD MODELS**

Designation	Order Number
DBDP06A4PAT8B/MA	XDB10352-000-01
DBDP06A4PAT8E/MA	XDB10353-000-01
DBDP06A4PAT8G/MA	XDB10354-000-01
DBDP06A4PAT8K/MA	XDB10355-000-01
DBDP06A4PAT8B/MB	XDB10033-000-01
DBDP06A4PAT8E/MB	XDB10034-000-01
DBDP06A4PAT8G/MB	XDB10035-000-01
DBDP06A4PAT8K/MB	XDB10036-000-01

