

APPLICATION NOTES

TECHNICAL NOTE TN 353

PROTECTIVE GROUNDING AND ELECTRICAL SHIELDING OF HYDRAULIC VALVES WITH INTEGRATED ELECTRONICS

CA58437-001; Version 2.1, 04/08

Copyright

© 2002, 2003, 2007, 2008 Moog GmbH
 Hanns-Klemm-Straße 28
 71034 Böblingen
 Deutschland

Telephone: +49 7031 622-0
 Fax: +49 7031 622-191
 E-mail: sales.germany@moog.com
 Internet: <http://www.moog.com/Industrial>

All rights reserved.

No part of this document may be reproduced in any form (print, photocopies, microfilm, or by any other means) or edited, duplicated, or distributed with electronic systems without our prior written consent.

Offenders will be held liable for the payment of damages.

Subject to change without notice.

We reserve the right to make changes to this document at any time and without specified reasons.

Completeness

This document is complete only when used in conjunction with the product-related hardware and software documentation required for the relevant application, as for example operating instructions of the valve and other manuals.

Selection and qualification of personnel

As specified in the product-related hardware and software documentation required for the relevant application, only users properly qualified and authorized for these tasks may work with and on our products.

Note

This document has been prepared with great care in compliance with the relevant regulations, state-of-the-art technology and our many years of knowledge and experience, and the contents have been generated to the best of the authors' knowledge. However, the possibility of error remains and improvements are possible.

Please feel free to submit any comments about possible errors and incomplete information to us.

Table of Contents

1 Overview.....	3
2 Equipotential Bonding and Protective Grounding	3
2.1 General Principles	4
2.2 Protective Conductors	4
2.3 Ground Loops	4
2.4 Machines with Poor Equipotential Bonding	4
3 Electrical Shielding.....	5
3.1 Cables.....	5
3.2 Connecting the Shielding.....	5
3.2.1 Connection to the Valve	5
3.2.2 Connection at the Control Cabinet Side.....	5
3.3 Isolated Shielding	6
3.4 Cable Routing.....	6
4 Quoted Standards.....	6

1 Overview

This technical note (TN) provides guidelines for protective grounding and electrical shielding of cables in applications using our hydraulic valves with integrated electronics.

! The valves should be used only in machines or plants that meet the requirements of the standard EN 60204-1 and of this TN.

! The protective conductor connection (\oplus) (if provided) is connected to the electronics housing or valve body. The insulation materials employed are designed for use in the safety extra-low-voltage range.

The field bus circuit connections (if provided) are only functionally galvanically isolated from other connected circuits.

To comply with safety regulations requires isolation from the mains according to EN 61558-1 and EN 61558-2-6 and limiting all voltages according to EN 60204-1.

We recommend using SELV/PELV power supplies.

2 Equipotential Bonding and Protective Grounding

Equipotential bonding is used to provide a relatively small potential difference within a system.

Protective grounding provides safety during operation of the machine.

The term "protective grounding" or "PE" designates only one single point within the system: the connection point of the external protective conductor. All other grounding connections (\oplus) are made via protective and equipotential bonding conductors.

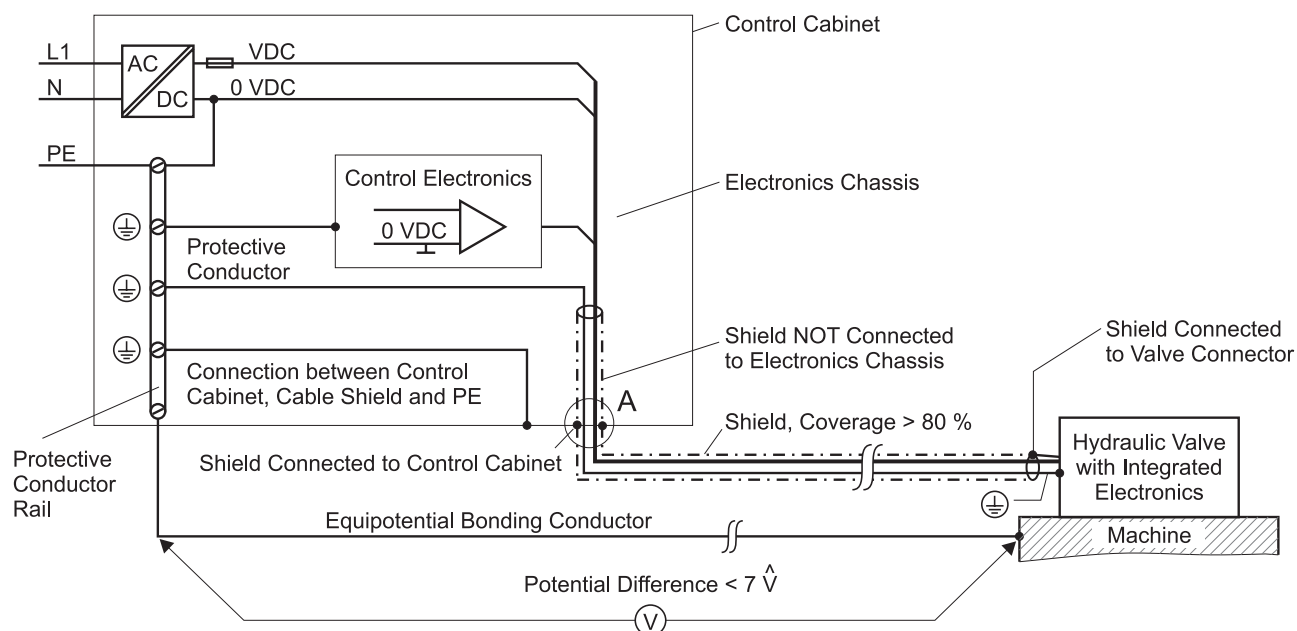

Figure 1: Equipotential bonding and protective grounding of machines (see also EN 60204-1) as well as electrical shielding of our hydraulic valves with integrated electronics

2.1 General Principles

- ! The equipotential bonding and protective conductor system for a machine using the valves must be set up according to EN 60204-1.

Please observe the following during set-up of equipotential bonding and protective grounding:

- All elements of the machine are to be connected using the equipotential bonding conductor.
- All elements of the machine having exposed metal surfaces are to be connected to the protective conductor rail using the protective conductor.
- All protective conductors and the equipotential bonding conductor in the main control cabinet are to be connected via the protective conductor rail to the protective grounding (PE).
 - ⓘ The cross section of the protective conductor is defined in EN 60204-1, section 8.
The following cross sections can be used as cross sections of equipotential bonding conductors:
 - up to a cable length of 200 m (656 ft)
16 mm² (4 AWG)
 - over a cable length of 200 m (656 ft)
25 mm² (3 AWG)
 - ⓘ The potential difference between any two points of a machine should not exceed 7 V peak (7 \hat{V}).
- The electrical shielding and the electrical ground of the electronics chassis are to be connected in a star-shaped manner to the protective conductor rail.
- The functioning of all equipotential bonding conductors and protective conductors according to EN 60204-1, section 18, is to be checked before the machine is released for normal operation.

2.2 Protective Conductors

The protective conductor prevents hazardous over voltage on any element of the machine in case of failures of the valve's power supply or short circuits between power supply and another cable to the valve.

- ! This protective conductor does not replace the standard equipotential bonding system described in chapter 2.1 of this TN. The protective conductor must not be used for equipotential bonding.

The valves must be connected to the protective grounding (PE) of the machine via a protective conductor. Please observe the following when connecting the protective conductor:

- The protective conductor must be made of copper.
- When using supply cables with a cross section of $S \leq 16 \text{ mm}^2$ (4 AWG) the protective conductor must have at least the cross section S .
- The protective conductor should be routed within the cable shield (see chapter 3.1 of this TN).
- The connection must be made using the pre-mating protective conductor contact pin (\ominus) of the valve connector or using the connection point (\ominus) of the valve body.

2.3 Ground Loops

Connecting a valve to the protective grounding (PE) via the equipotential bonding system as well as via the valve's protective conductor can result in a current flowing in the resulting "ground loop". This current can cause significant disturbances within the machine.

Please observe the following to minimize disturbances caused by ground loops:

- Route the valve's supply and signal cables as close as possible to the equipotential bonding conductor (see chapter 2.4 of this TN).
- The impedance of the equipotential bonding system should be less than 10 % of the impedance of the system consisting of the protective conductor and cable shields.

2.4 Machines with Poor Equipotential Bonding

In some industrial applications only a poor equipotential bonding is achieved. In this case an effective equipotential bonding system according to EN 60204-1, section 8, must be set up (see chapter 2 of this TN).

- ! If this cannot be achieved the machine does not meet EN 60204-1!
Since the valve's protective conductor (\ominus) connection can carry high currents extreme caution is necessary in this case (see also chapter 3.3 of this TN).

3 Electrical Shielding

An effectively shielded machine is highly insensitive to external sources of disturbance. In addition, an effective shielding significantly reduces the disturbances radiated by the machine.

A functioning equipotential bonding system is the basis for an effectively shielded machine. The general requirements of chapter 2 of this TN must be met for the cable shielding to be really effective.

3.1 Cables

Please observe the following when selecting cables the valves:

- Shielded cables should be used exclusively.
- The cable shield should be made of copper braiding with a coverage of at least 80 %.
- The individual wires must be made of copper and have a cross section of at least 0,2 mm² (24 AWG) according to EN 60204-1, table 5.
- Twisted pair cabling is to be used in environments with high noise level.
- The protective conductor should be routed within the cable shield (see chapter 2.2 of this TN).

3.2 Connecting the Shielding

- ⓘ Metal shell connectors with pre-mating protective grounding contact pin (⊖) according to EN 60204-1 are to be used when connecting the shield.

3.2.1 Connection to the Valve

The cable shield must be connected electrically to the connector's metal shell.

3.2.2 Connection at the Control Cabinet Side

Connection at the control cabinet side can be done by cable leadthrough or by connectors.

Cable Leadthrough

Please observe the following when connecting the shielding to the control cabinet:

- The control cabinet and the protective conductor rail (⊖) must be connected electrically (see Figure 1).

- The cable shield must be properly connected to the control cabinet via a low impedance connection.

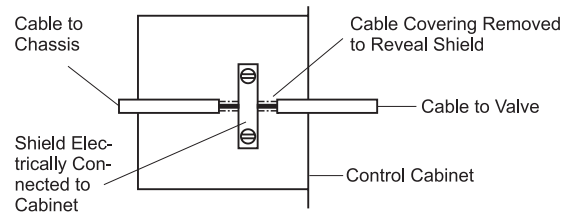

Figure 2: Connecting the cable shield to the control cabinet (detail A of Figure 1)

- Route the cable shield unbroken through the wall of the EMC-compliant control cabinet as close as possible to the electronics chassis, e.g., via PG thread cable glands.
- ⓘ The cable shield must not be connected to the electronics chassis!

Connectors

Please observe the following when connecting the shielding to the control cabinet:

- The control cabinet and the protective conductor rail (⊖) must be connected electrically (see Figure 1).
- Connect the shield of the cable coming from the valve to the shell of the removable connector.
- ⓘ The shell of the connector mounted firmly in the control cabinet must provide a good electrical connection to the wall of the control cabinet.
- Connect the connector mounted in the control cabinet's wall to the shielding within the cabinet.

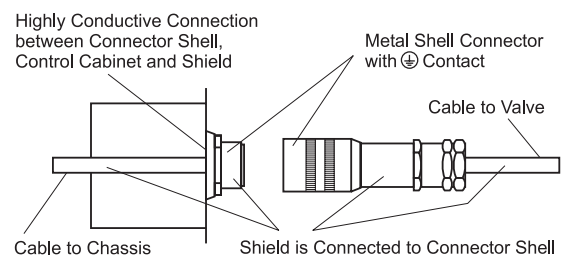

Figure 3: Connecting the cable shield to the control cabinet via connectors (detail A of Figure 1)

- Route this shielding within the cabinet as close as possible to the electronics chassis.
- ⓘ The cable shield must not be connected to the electronics chassis!

3.3 Isolated Shielding

Isolated shielding may be necessary if connection of the shield at both cable ends is not desirable, as for example in a machine with poor equipotential bonding. In general this is necessary only if it is not possible to install a good equipotential bonding system.

Please observe the following when connecting an isolated shielding system:

- Use only metal shell connectors with pre-mating protective grounding contact pin (⊕) according to EN 60204-1.
- The cable shield must be connected electrically to the connector's metal shell.
- The control cabinet and the protective conductor rail (⊕) must be connected electrically (see Figure 1).
- Connect the cable shield to the control cabinet via a capacitor (e.g., ceramic capacitor 10 nF / 100 VDC).

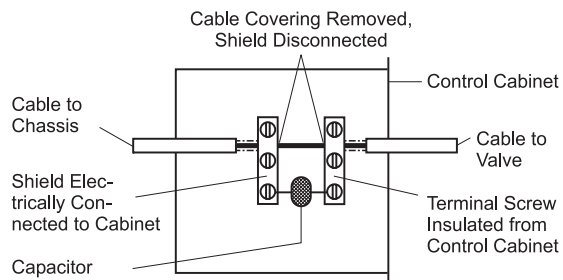

Figure 4: Connecting the isolated shielding system to the control cabinet (detail A of Figure 1)

- Install a separate shielding within the control cabinet. This shielding must be connected to the cabinet's wall and must be routed as close as possible to the electronics chassis.
- ⓘ This shielding must not be connected to the electronics chassis!

3.4 Cable Routing

The cable routing within a machine must meet the following general guidelines:

- Route power supply cables and signal cables in separate cable conduits.
- Route the valve's connection cables as close as possible to the equipotential bonding conductor to minimize disturbances caused by ground loops (see chapter 2.3 of this TN).
- Avoid routing cable conduits close to strong electromagnetic disturbance sources such as electric motors or transformers.
- If the danger of lightning strokes is not completely ruled out by cable routing, appropriate precautions, as specified in EN 60204-1, must be taken.

4 Quoted Standards

EN 60204-1:2006

Safety of machinery - Electrical equipment of machines - Part 1: General requirements

EN 61558-1:2005

Safety of power transformers, power supplies, reactors and similar products - Part 1: General requirements and tests

EN 61558-2-6:1997

Safety of power transformers, power supplies, reactors and similar products - Part 2-6: Particular requirements for safety isolating transformers for general use

For your notes.

MOOG.COM/INDUSTRIAL

For the location nearest you, contact
moog.com/industrial/globallocator

Argentina	+54	11 4326 5916	info.argentina@moog.com
Australia	+61	3 9561 6044	info.australia@moog.com
Austria	+43	664 144 65 80	info.austria@moog.com
Brazil	+55	11 3572 0400	info.brazil@moog.com
China	+86	21 2893 1600	info.china@moog.com
Finland	+358	9 2517 2730	info.finland@moog.com
France	+33	1 4560 7000	info.france@moog.com
Germany	+49	7031 622 0	info.germany@moog.com
Hong Kong	+852	2 635 3200	info.hongkong@moog.com
India	+91	80 4120 8799	info.india@moog.com
Ireland	+353	21 451 9000	info.ireland@moog.com
Italy	+39	0332 421 111	info.italy@moog.com
Japan	+81	463 55 3615	info.japan@moog.com
Korea	+82	31 764 6711	info.korea@moog.com
Luxembourg	+352	40 46 401	info.luxembourg@moog.com
Netherlands	+31	252 462 000	info.netherlands@moog.com
Norway	+47	64 94 19 48	info.norway@moog.com
Russia	+7	31713 1811	info.russia@moog.com
Singapore	+65	6773 6238	info.singapore@moog.com
South Africa	+27	12 653 6768	info.southafrica@moog.com
Spain	+34	902 133 240	info.spain@moog.com
Sweden	+46	31 680 060	info.sweden@moog.com
Switzerland	+41	71 394 5010	info.switzerland@moog.com
United Kingdom	+44	1684 296600	info.unitedkingdom@moog.com
USA	+1	716 652 2000	info.usa@moog.com

© 2002, 2003, 2007, 2008 Moog GmbH

Technical Note TN 353
(CA58437-001; Version 2.1, 04/08)

All rights reserved.
Subject to change without notice.