

# Fiber Optic Rotary Joint

Model 285 / 286

Focal Technologies Corporation, a Moog Inc. company, has over 30 years of expertise in supplying standard and custom marine products for harsh environments and is a leading manufacturer of high performance and high quality fiber optic rotary joints. Contact Focal for assistance in selecting the best solution for your requirements.



The FO285 (single-channel singlemode) and the FO286 (single-channel multimode) are passive and bidirectional, and allow the transfer of optical signals across rotational interfaces. Both models also offer other benefits of fiber optics, including low spark hazard.

With a body diameter of only 9.5 mm and lengths of 26 mm and 19 mm for the FO285 and FO286 respectively, both units are ideally suited to applications where size and weight are critical issues.

Both models can be combined with our electrical and / or fluid slip rings, providing a single, compact package for optical signals, electrical power and fluid transfer.

## Features

- Provides rotary coupling for a multimode fiber link
- Passive bidirectional device
- Alternative drive coupling and mounting arrangements are available (consult factory for specification details)
- Stainless steel, aluminum or anodized aluminum housing
- Ruggedized design
  - MIL-STD-167-1 ship vibration
  - MIL-STD-810 functional shock (40 g)

## Benefits

- Can be integrated into existing slip ring designs
- Passive bidirectional optical transmission
- Can be combined with our electrical slips and fluid unions
- Long life

## Applications

- Unmanned ground vehicles
- Robots
- Surveillance systems
- Industrial automation
- Unmanned aerial vehicles and sub-systems

# Specifications

FO285/286 Specifications		
	FO285 (Singlemode)	FO286 (Multimode)
<b>Fiber Size (Microns)</b>	9/125 SMF-28. Consult factory for other SM fiber types	50/125 or 62.5/125. Consult factory for other sizes
<b>Material</b>	Stainless steel	Stainless steel or aluminum
<b>Insertion Loss</b>	Typical < 1.5 dB, Maximum < 3.5 dB	Typical < 1.5 dB, Maximum < 2.5 dB
<b>Rotation Variation</b>	Typical < 0.5 dB, Maximum < 1.5 dB	Typical < 0.5 dB, Maximum < 1.0 dB
<b>Back Reflection</b>	Typical 22 dB, Minimum 18 dB Optional: Typical 40 dB, Minimum 35 dB.	Typical 22 dB, Minimum 18 dB
<b>Wavelengths</b>	Suitable for operation over full CWDM band (18 wavelengths from 1271nm to 1611nm in 20nm increments), tested at 1310nm and/or 1550nm. Consult factory for other wavelengths such as 900-1100nm band (tested at 1060nm)	Suitable for operation in 850nm and 1300nm multimode bands or 1300nm and 1550nm multimode bands. Consult factory for other wavelengths such as 900-1100nm band (tested at 1060nm)
<b>Rotational Speeds</b>	To 1000 rpm. Higher rotational speeds should be discussed with the factory	
<b>Temperature</b>	-55 to + 75 °C. Consult factory for extended range	
<b>Vibration</b>	Per MIL-STD-167-1A	
<b>Shock</b>	40 g/11 ms sawtooth per MIL-STD-810 Method 516	
<b>Terminations</b>	Pigtailed with cable and terminated with connectors to meet customer's requirements.	
<b>Pigtail Length</b>	Up to 3 meters standard. Consult factory for longer lengths	

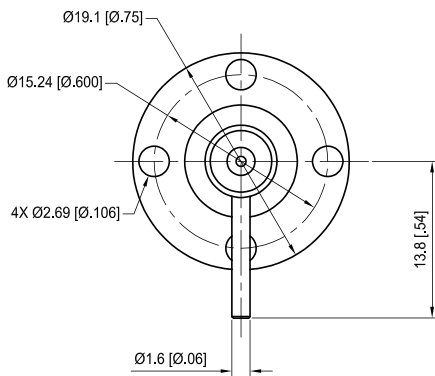

MODEL 285 SM L = 17 [.68]  
MODEL 286 MM L = 11 [.43]

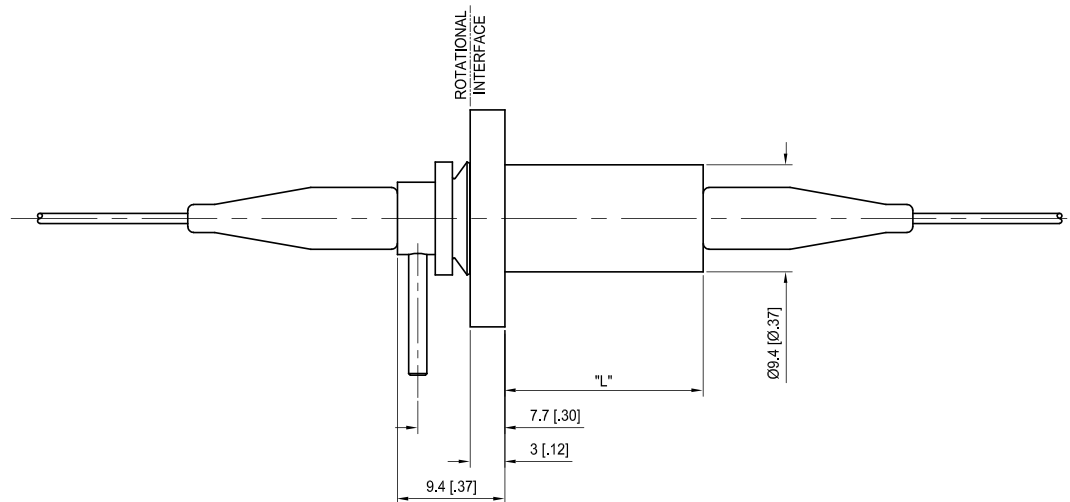

Also available with right angle. Please contact factory for details.