

Optical Encoders

TYPICAL APPLICATIONS

Low cost motion detection for motors used in:

- Factory automation
- Packaging and printing products
- Office equipment and computer peripherals
- Robotic tape storage and retrieval
- Semiconductor handling and insertion machines
- Industrial automation
- Computer controlled embroidery machines
- Positioning tables
- Machine tools

FEATURES

- Two channel quadrature output with optional index pulse
- No signal adjustment required
- Low cost
- Small size
- Resolutions up to 1024 counts per revolution
- -40°C to 100°C operating temperature
- TTL compatible
- Single 5 volt supply

BENEFITS

- Feedback information may be used in conjunction with a position controller for precise motor shaft position
- Encoders used in conjunction with a 4-quadrant velocity controller, such as the BDA-Q4-70-10, allow precise velocity control of brushless motors



All Moog Components Group motors can be fitted with an encoder. Moog Components Group uses the Hewlett-Packard HEDS and HEDM series of optical encoders as their standard offering. Other encoders are available; if you have a specific need please contact one of our applications engineers.

RENCO RCML15 encoders are also a standard offering.



MOOG
COMPONENTS GROUP

SPECIFICATIONS

Specifications at 25°C (77°F)	HEDS 5500	HEDS 5540	HEDM 5500
Counts Per Revolution	96 to 512	96 to 512	1000 to 1024
Number of Channels	Two	Two + Index	Two
Supply Voltage (V_{cc}) (vdc)	4.5 to 5.5	4.5 to 5.5	4.5 to 5.5
Supply Current (I_{cc}) (mA – typical)	17	17	17
Load Capacitance (C_L) (pF max)	100	100	100
Count Frequency (f) (kHz max)	100	100	100
Pulse Width (P) (°e)	180 +/- 45	180 +/- 45	180 +/- 45
Phase Shift (ϕ) (°e)	90 +/- 20	90 +/- 20	90 +/- 20
Pulse Width Error (ΔP) (°e max)	45	35	45
Index Pulse Width (P_o) (°e max)	N/A	125	N/A
Signal Rise Time (t_r) (ns typ.)	200	180	180
Signal Fall Time (t_f) (ns typ.)	50	40	40
Operating Temperature (°C)	-40 to 100	-40 to 100	-40 to 100
Velocity (rpm) (max.)	30000	30000	30000
Acceleration (rad/sec ²) (max)	250000	250000	250000

Definitions

- **Count (N)** – the number of bar and window pairs or counts per revolution (CPR) of the codewheel
- **Pulse Width (P)** – the number of electrical degrees that an output is high during 1 cycle. This value is nominally 180°e or 1/2 cycle
- **Pulse Width Error (ΔP)** – the deviation, in electrical degrees, of the pulse width from its ideal value of 180°e
- **Phase (ϕ)** – the number of electrical degrees between the center of the high state of channel A and the center of channel B. This value is nominally 90°e for quadrature output.
- **Phase Error (Δf)** – the deviation of the phase from its ideal value of 90°e.
- **Index Pulse Width (P_o)** – the number of electrical degrees that an index output is high during one full shaft rotation. This value is nominally 90°e or 1/4 cycle.

Ordering Information

In order for us to provide the correct encoder for your application, it is necessary that you provide us with:

- # of channels
- CPR (counts per revolution)
- Whether or not Differential Lines Drivers are required

To facilitate the correct selection, simply fill in the blocks below.

HEDS 55

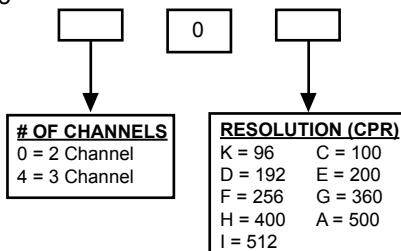

HEDM 55

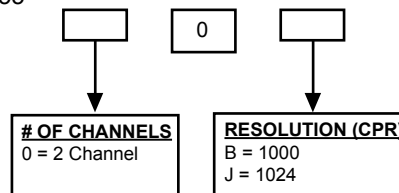

Note: If Differential Line Drivers are needed, simply substitute an L into the part # (ex. HEDL)

EXAMPLE

You need a 2-channel encoder with a line count (CPR) of 512, the correct part # would be: HEDS-5500-I.

If you needed the 2-channel, 512 CPR, but with differential line drivers, the correct part # would be: HEDL-5500-I.

Package Dimensions

HEDS-5500 / 5540, HEDM-5500

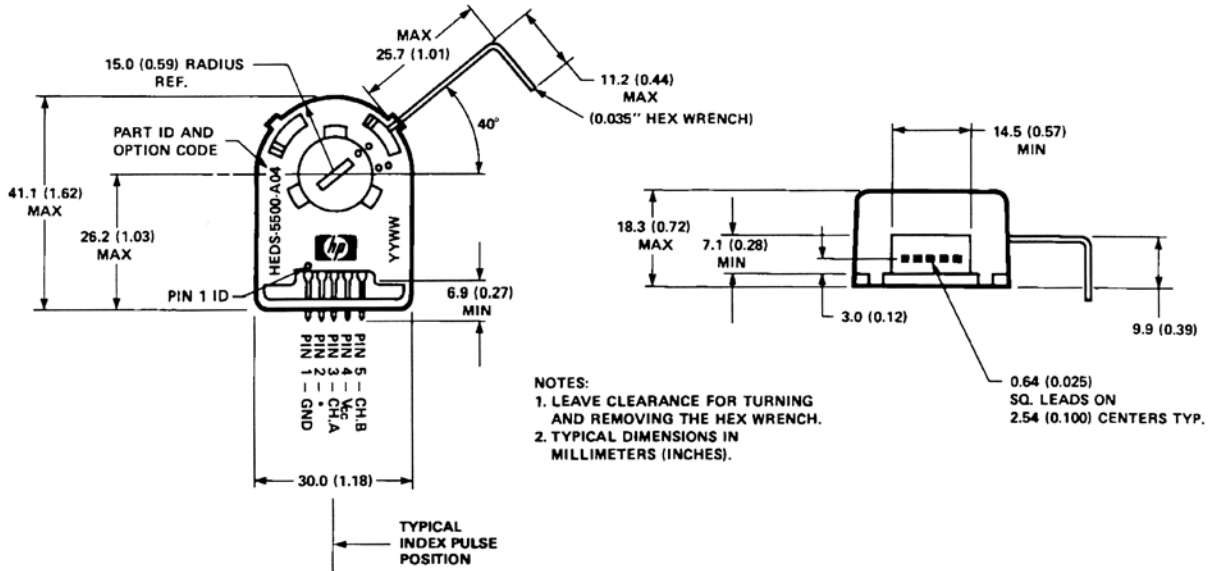

Note: For the HEDS-5500 and HEDM-5500, Pin #2 is a No Connect. For the HEDS-5540, Pin #2 is CH. I, the index output.

HEDS-5600 / 5640, HEDM-5600

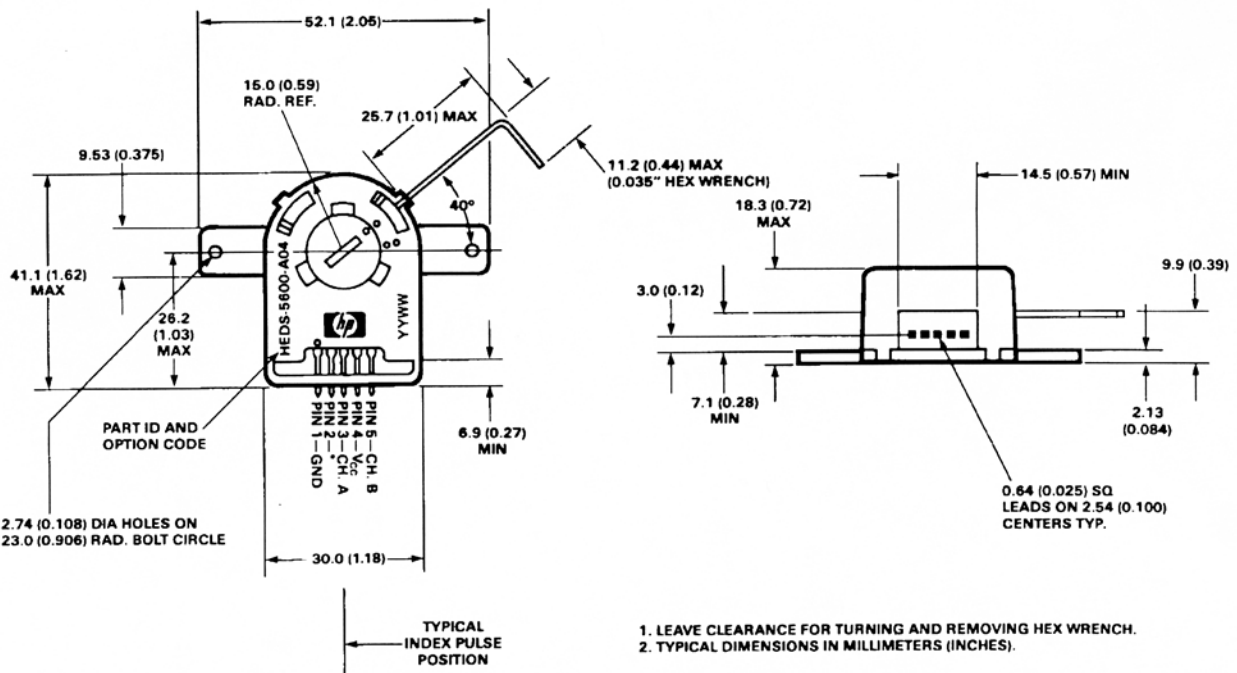

Note: For the HEDS-5600 and HEDM-5600, Pin #2 is a No Connect. For the HEDS-5640, Pin #2 is CH. I, the index output.

Encoders

Output Waveforms

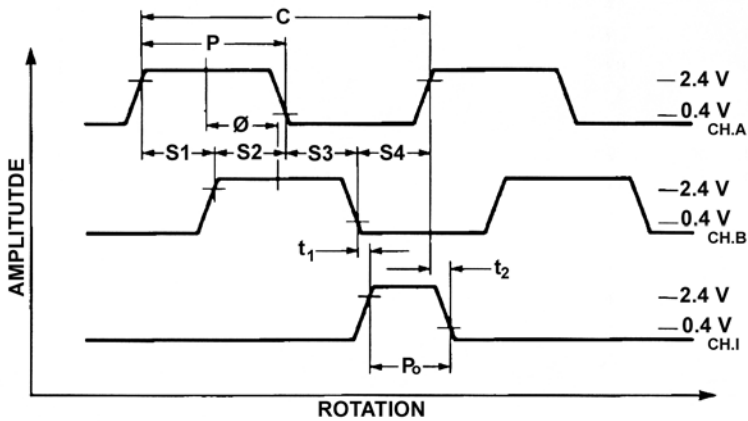

HEDL Parameters

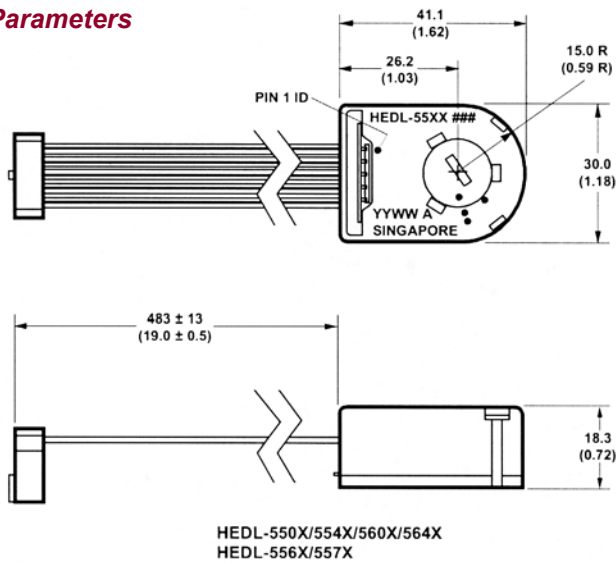

NOTE: DIMENSIONS IN MILLIMETERS (INCHES)

Waveforms

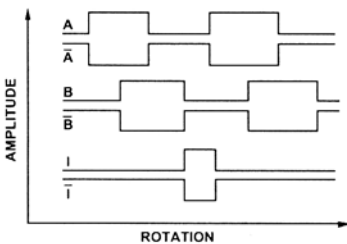

Block Diagram

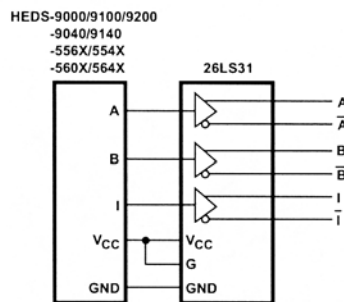

Pinouts

10-PIN CONNECTOR		
NO.	COLOR	PARAMETER
1	BROWN	NC
2	RED	V _{CC} (+ 5 V)
3	ORANGE	GND
4	YELLOW	NC
5	GREEN	\bar{A}
6	BLUE	A
7	VIOLET	\bar{B}
8	GREY	B
9	WHITE	\bar{I} (INDEX)

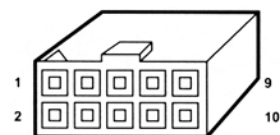

10 POSITION IDC CONNECTOR
CENTER POLARIZED.