

Digital Motion Control for Brushless Motors



T 161 and T 164 Series

Introduction

Leading Edge Technology Guarantees Success

Modern industrial production is characterised by continuing development in production automation. This development is vital in ensuring the production process remains efficient and economical in a fast changing world. Servo drives play a critical role in the development of automation systems. Modern servo drives must provide high performance solutions to improve production efficiency while keeping costs at a minimum.

MOOG brushless servo drives are specifically designed to meet the requirements of the modern production environment.

The combination of compact, high performance servomotors with advanced digital servo controllers results in the optimum price/performance solution for your application.

The product range comprises servomotors of different dimensions with matched servo controllers for the commutation and control of the motors.

In addition, multi-axis power supplies together with all the necessary accessories (ventilation units, heat-sinks, cables, etc.) completes the package for every application.

This catalogue contains information on the MOOG range of servo-amplifiers, powersupplies and interface cards. The servoamplifiers are available in two package variants and in various different power ranges. Interface cards are available for the Siemens Simatic S5 and PC host control systems.

164 Series

Package form
Demand signal
DC Bus Voltage [V]
Continuous Current [A_s]*
Peak Current [A_s]*

Panel mounting box
 ± 10 V; CAN (Option)
325
7 to 80
14 to 200

*All current values are peak of sine. $A_s = \sqrt{2}A_{eff}$

Components of a MOOG Servo Drive System

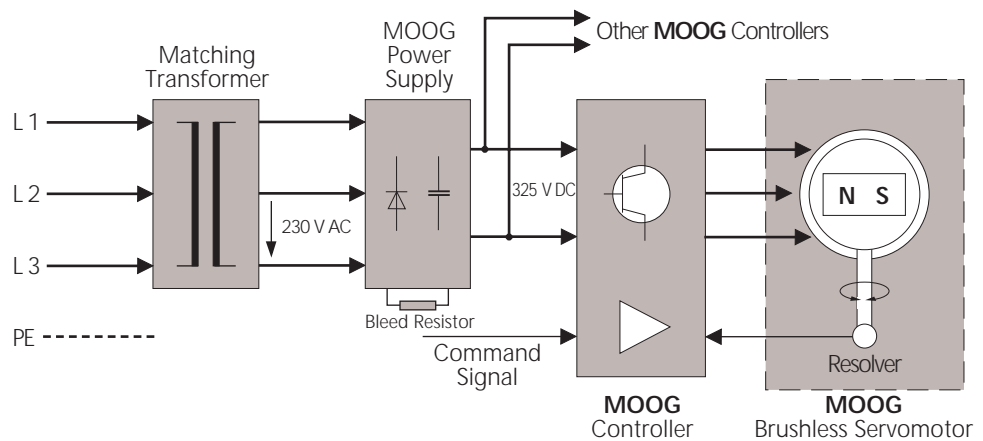

Our quality system is certified to ISO 9001



This catalogue is intended for suitably qualified personnel only. The user is responsible to ensure that the components described herein are fit for their intended

purpose and meet all required safety regulations. Please consult the factory if in doubt.

Typical Applications

- Robots
- Handling Systems
- Transfer Lines
- Textile Machines
- Packaging Machines
- Plastic Machines
- Paper and Woodworking
- Flying Shears and Saws
- Punching and Stumping Machines

MOOG Brushless Servomotors

offer the following features:

- Very compact dimensions
- Low inertia for dynamic performance
- Low weight
- Reliable and robust

MOOG Digital Servoamplifiers

The performance advantage of MOOG Servomotors can be fully achieved using the latest generation of digital servoamplifiers from MOOG.

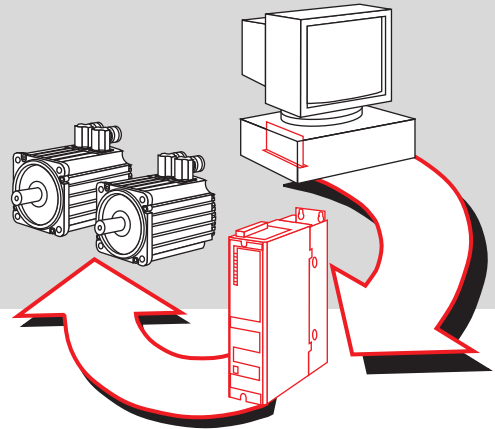

Setting Standards in Technology and Service

Advances in technology have led to an ever increasing use of digitalisation. MOOG servodrives are no exception. Speed, winding temperature and other physical quantities are sampled periodically by a fast microprocessor and this data is used to commutate, control and protect the drive system. This allows complex algorithms to be realised which give better motor performance and easy set-up.

sales and service coverage provided by MOOG Subsidiaries together with a growing network of Sales Partners.

Apart from the development and manufacture of brushless Servomotors, MOOG also offers the hardware and software components necessary to implement complete drive systems. MOOG Customers benefit from world-wide

MOOG supplies complete Servodrive Systems

T 161 Series

Technical Data

Model		T 161-901	T 161-902
Continuous Current	[A _S]*	3,5 / 6**	4,7 / 11**
Peak Current	[A _S]*	8	20
Continuous Power	[kW]		
Dimensions W x D x H	[mm]	60,96 x 226,9 x 262,9	60,96 x 226,9 x 262,9

*All current values are peak of sine. $A_S = \sqrt{2}A_{\text{eff}}$

The T161 Series

consists of modules which are plugged into a 19" rack containing a backplane. Up to 6 servo-amplifiers may be plugged into one rack. Each rack also requires a T160 power supply which supplies high voltage DC and logic level voltages for up to 6 amplifiers. The servoamplifier features digital speed control, commutation and fault monitoring. Analogue current loops guarantee the highest possible bandwidth for dynamic mo-

tor performance. The T161 Series is optimised for motors up to 2.5 kW.

Encoder Simulation Option

An incremental position signal with a programmable resolution of up to 8192 lines per motor revolution is generated from the resolver position feedback. The incremental position is transmitted as differential quadrature pulse outputs and a differential marker pulse output which may be set at any motor position.

User Interfaces

Analogue Inputs

±10 V Demand Input
0-10 V Torque Limit

Digital Inputs

Enable, Speed Limit
Speed / Torque Mode Select
Limit Switches

Analogue Outputs

Current Monitor
Speed Monitor

Digital Outputs

Thermal Limit
Drive Fault
System Ready
Encoder Simulation (Option)

Status Display

LED's on the front panel show drive status

Communication

RS232 / 485 Interface
CAN Bus (Option)



T 161-903	T 161-904	T 160-901/2
6,5 / 15**	18**	Power Supply
30	60	
		0,8/2,5** (1 x 230 V AC) 2,5/7,5** (3 x 230 V AC)
60,96 x 226,9 x 262,9	91,44 x 226,9 x 262,9	60,96 x 226,9 x 262,9

** Forced air cooling $Q \geq 35 \text{ m}^3/\text{h}$

CAN Interface Option

The use of a high speed CAN digital interface to replace the old $\pm 10\text{V}$ demand signal opens up the full potential of digital drive technology. By integrating higher level motion control functions in the drive, the advantages of distributed control systems can be exploited in full. Only a single twisted-pair cable is needed between the Host Controller and the servodrives. There are no analog control cables,

no encoder feedback cables and no additional RS232/RS422 cables required. MOOG CAN drives offer two modes of operation. In both cases, the position control loop is closed on the servodrive eliminating the need for a separate position control card. With the Interpolation Mode version, the motion profile is generated on the host controller allowing complex path control. With the Profile Mode version, the profile is generated on the drive

itself, allowing point to point motions and electronic gearing between axes. The functionality of MOOG CAN drives allow cost effective and reliable system solutions to be quickly realised. The 19" rack plug-in system and the parameter download over CAN allow fast and reliable exchange of T161 drives in the field thereby reducing machine downtime.

160 Power Supply

Two versions of the 160 power supply are available, one which generates the logic voltage supply from the main bus and one which uses a separate 24 V DC input. The latter version allows communication with the drive to function even after removal of the high voltage supply.

Block Diagram of the T 161 Digital Servo Controller

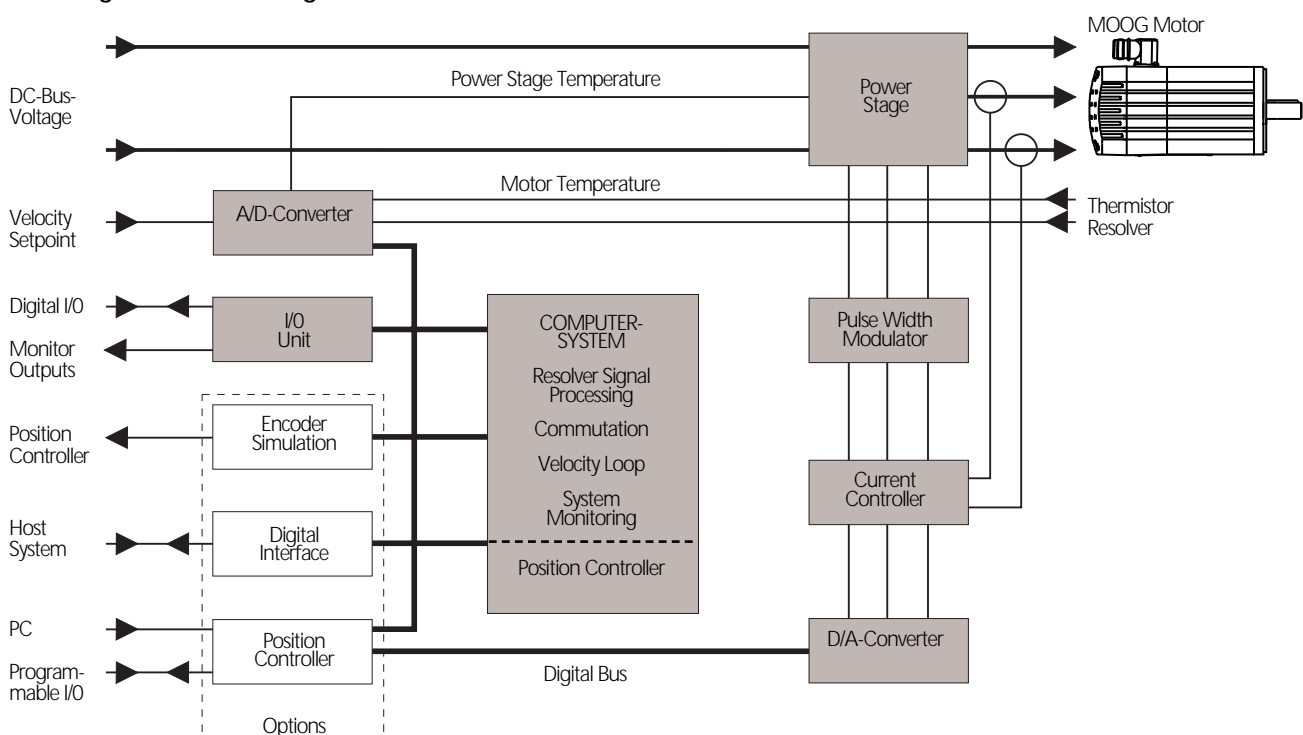

T 164 Series

Technical Data

Model		T 164-901	T 164-903
Continuous Current	[A _S]*	7	14
Peak Current	[A _S]*	14	28
Continuous Power	[kW]		
Dimensions W x D x H	[mm]	76 x 254 x 312	76 x 254 x 312

*All current values are peak of sine. $A_S = \sqrt{2}A_{\text{eff}}$

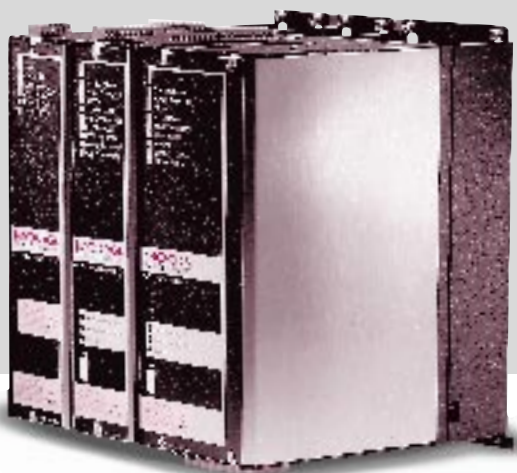

The T164 Series

features a panel mounting construction and covers the complete range of MOOG motors up to 10 kW. Screw terminal connectors allow easy system installation. A built-in fan is included for optimum heat dissipation. The T164 series offers the same functionality and expansion options as the T161

series. In addition, a single-axis position control card is available which plugs into the T164 servo-amplifier. High power DC voltage is supplied by the 150 Power Supply which also features a ballast circuit to absorb energy regenerated by the motor. For large loads, an external ballast resistor, (up to 2.5 kW continuous, 36 kW peak), is available as an option.

User Interfaces

Analogue Input

±10 V Demand, switchable between speed and torque control

Digital Inputs

Drive Enable
Limit Switch Inputs (Option)
Torque / Speed mode select (Option)
Automatic / Manual mode select (Option)

Analogue Outputs

Two programmable test points on the front panel. e.g. to monitor speed or current.

Digital Outputs

Thermal Limit
Drive Fault
System Ready (Option)
Encoder Simulation (Option)

Status Display

LED's on the front panel show drive status

Communication

RS 232 / 485 Interface
CAN-Bus (Option)

T 164-905	T 164-907	T 164-909	T 150-901
28	56	80	Power Supply
56	112	200	
			5 (1 x 230 V AC) 15 (3 x 230 V AC)
76 x 254 x 312	127 x 254 x 312	127 x 254 x 312	76 x 254 x 312

CAN Interface Option

The CAN functionality described for the T161 Controller Series is also available for the T164 Series.

Point Card Option

Point is a complete single axis motion control card which plugs into the drive and allows the drive to operate as a standalone motion controller. The card also contains 9 digital inputs, 5 digital outputs and a serial interface.

A powerful motion control language based on BASIC allows a

wide variety of motion tasks to be programmed. A program development environment is provided and user programs may stored on the Point card in EEPROM. An encoder input, high speed registration input and a CAN interface are also available as options.

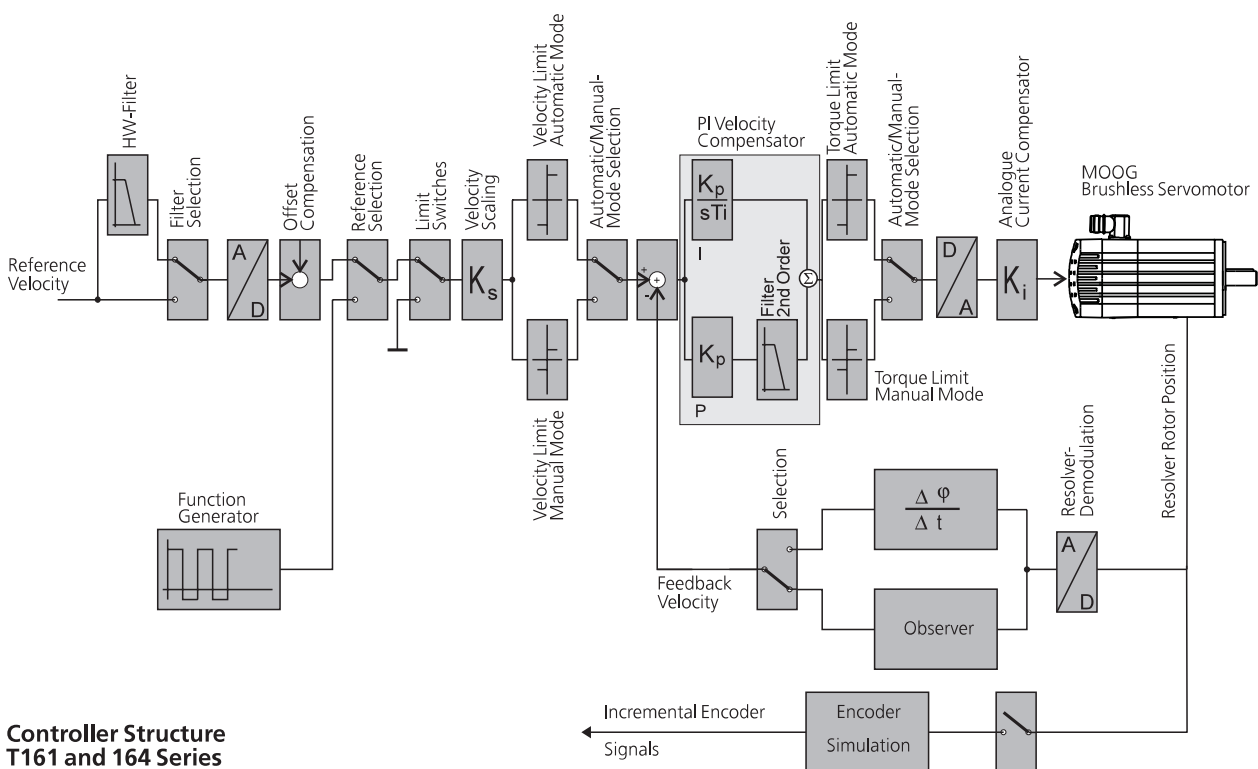

**Controller Structure
 T161 and 164 Series**

S5 *SERVOLINK*[®]

Simatic[®] S5 Interface for Digital Servodrives

Description

The S5 ServoLink card from MOOG offers a high speed serial interface between the Simatic S5 from Siemens and the MOOG digital servodrives. Using the high speed CAN interface to replace the ± 10 V analogue demand signal opens up the full potential of digital control. Integrating higher level motion control functions in the servodrive allows the advantages of distributed control systems to be fully realised. Highly synchronised motion control is possible without any additional

positioning card in the PLC. Up to 47 axes may be controlled from one PLC.

The S5-ServoLink card is a standard plug-in card for the 115U, 135U and 155U S5 PLC's. The card implements all the necessary protocol to allow MOOG intelligent servodrives to be directly accessed from PLC programs using a library of Step 5 function blocks provided.



Features:

- Point to point motions
- Electronic gearing and camming functions
- Motion parameters freely programmable from the S5 Program
- Servodrive data (position, status, etc.) available to the PLC program
- Up to 16 drives may be controlled by one card, up to 3 cards in one PLC
- Compatible with all S5-115U, 135U and 155U PLC's (a version for 95U and 100U is in preparation)

Advantages

Intelligent servodrives networked via CAN bus have the following advantages compared with servodrives having an analog speed interface:

- No extra position controller necessary. → Reduced costs. One S5 ServoLink card can control up to 16 axes.
- Lower installation and wiring costs using a serial bus. → Less possibility of wiring errors.
- No more analog interfaces. → No noise or drift problems.
- Status and diagnostic information available in the PLC. → Higher availability and easier to service.
- Step5 motion functions available. → Easy to program.
- Modular decentralised concept. → Simplifies testing and commissioning.

S5 SERVOLINK® Simatic®S5 Interface for Digital Servodrives



Details of Operation

Generation of motion profiles, transmission of data for electronic gearing and CAM functions and position loop closure is performed on the servo amplifier. The PLC parameterises these functions using the library of function blocks provided, (see example below). Programming can be done either directly in Instruction List or graphically using function plans and ladder logic.

To perform a point to point move,

the PLC program calls the MOVE-ABSOLUTE function block and sets the required acceleration, max. speed and target position. Actual position and status information is sent every cycle from the servodrive to the PLC. This allows the PLC to determine the position of the drive and when the motion profile has been completed.

To perform electronic gearing any one axis can be configured as a gearing master. This master axis will then broadcast its position on the CAN bus every 2 ms. Any of the

other drives can be configured as slave axes. The relationship of the slave position to the master is defined by a table which is stored in each slave drive. This allows electronic gearing or CAM functions to be programmed.

Gear ratios may be set on the master and on each slave. The amplitude and offset of the CAM table can be changed every CAM cycle allowing very flexible systems to be realised.

The drives can also be run in speed

control mode with a programmable acceleration ramp or in torque control mode with a programmable maximum speed.

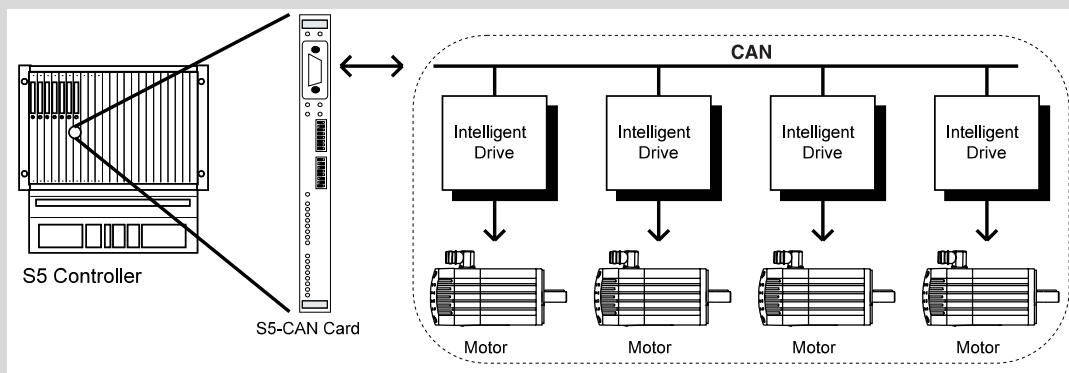

```

Example
L      KB      0      ;Check DRIVE_JOB_STATUS (D_J_S)
L      MB      101    ;MB101 = D_J_S
<F
SPB    =DJS1    ;Jump if currently moving

A      DB      201    ;Data block for drive 1
L      KH      0000
T      DW      8      ;Target position (high word)
L      KH      0000
T      DW      9      ;Target position (low word)
L      KF      +100
T      DW      10     ;Maximum speed in percent
L      KF      +80
T      DW      11     ;Acceleration in percent
L      KH      0008
T      DW      2      ;Send MOVE ABSOLUTE command
L      KH      0001
T      MB      101    ;Set D_J_S to 1
BEA
    
```

```

DJS1:
A      DB      201    ;Data block for drive 1
L      DW      3      ;Load status word
T      MW      240
UN     M        240.2 ;Check target_position_reached bit
BEB

L      KB      0
T      MB      101    ;Set D_J_S to 0
BE
    
```

This example shows an absolute move to position 0 with 100% maximum speed and 80% acceleration. The absolute values of speed and acceleration are initialised over CAN at start-up. During the move, the target_position_reached bit is checked every PLC cycle. Functions available include Speed and Position loop closure, Point-to-Point Profile Generation, Electronic Gearing and CAM Function. Status information can also be monitored on-line.

PC *SERVOLINK*[®]

PC Interface for Digital Servodrives

Description

The PC ServoLink communication card from MOOG allows PC Motion Control Programs to access the functionality of MOOG's intelligent servodrives with a direct digital link. The ServoLink card communicates with MOOG drives using CAN, a serial bus which because of its high reliability and extremely short reaction times has become a widely used standard in the automotive and industrial automation sectors.

Using the library of motion

functions supplied, (C source code), the user can easily program point to point motions and electronic gear and cam functions.

Features

- Easy connection of intelligent servodrives to a PC using CAN-Bus
- Point to point motions
- Electronic gearing and camming functions
- Motion parameters set by the PC Program
- Servodrive data (position, status, etc.) available to the PC
- Up to 32 drives may be controlled by one card
- May be plugged into any PC with a free ISA-bus slot

Advantages

Intelligent servodrives networked via CAN bus have the following advantages compared with servodrives having an analog speed interface:

- No extra position controller necessary. → Reduced costs. One PC ServoLink card can control up to 30 axes.
- The motion control functions are performed by the servodrive. → PC resources available for other functions.
- Lower installation and wiring costs using a serial bus. → Less possibility of wiring errors.
- No more analog interfaces. → No noise or drift problems.
- Status and diagnostic information available in the host PC. → Higher availability and easier to service.
- High level motion functions available. → Easy to program.
- Modular decentralised concept. → Simplifies testing and commissioning.

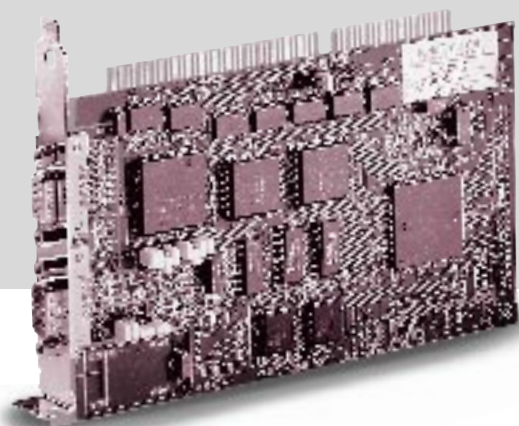

PC *SERVO*LINK® PC Interface for Digital Servodrives



Functional Details

MOOG intelligent servodrives contain an integrated position controller. This allows point to point motions as well as electronic gear and cam functions to be performed directly on the drive. The PC does not need to generate the motion profile. Instead only motion parameters such as distance to move, acceleration etc. are transmitted to the drive. The PC therefore can concentrate fully on the process control and visualisation.

The ServoLink card provides a buffer for the communication and also generates a time-base which is used to exactly synchronise all the drives on the network. This allows the start and finish of motions to be controlled precisely and also provides tightly coupled electronic gearing over CAN. The card also stores the actual positions of the axes and status information which is transmitted cyclically from each drive. A library of motion functions in C is provided to simplify programming. This includes absolute and relative moves, jog

and torque control, electronic gearing, motor brake on/off, error message handling and many other functions. Part of a sample program is shown below.

Real Time Requirement

Because the servodrive generates its own profile and the PC ServoLink card buffers all communication with the drives, the PC has no real time requirement.

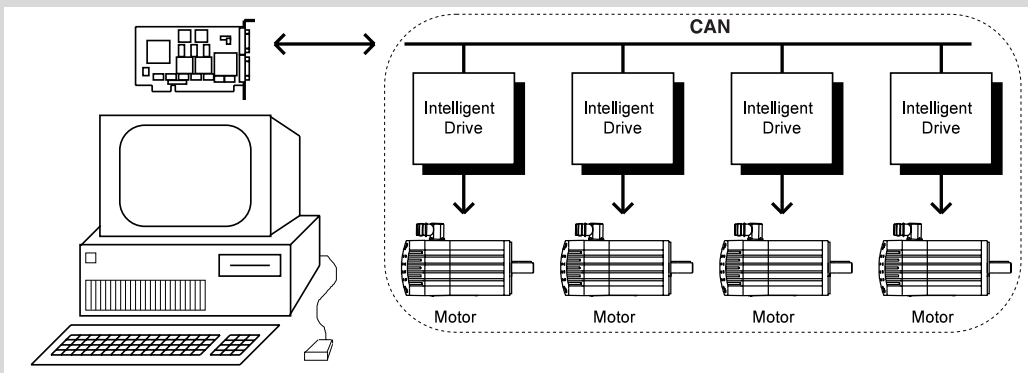

Sample Program

This Sample Program starts a point to point move. During the motion, the actual position of the drive is displayed. As soon as the drive has reached the target position, a notice is printed on the screen.

```
printf("Moving X axis now.\n");
start_move(x_axis, x_pos, x_vmax, x_amax);
while( in_motion(x_axis) )
{
    get_position(x_axis, &position);
    printf("x-axis now at position: %ld \n", position);
}
printf("\nX axis at target position.\n");
```

Technical Data

Plug-in Card for PC-AT Bus (Length 185 mm)
On-board CPU handles CAN Protocol
ISO CAN Standard
Optional Galvanic Isolation
Optional Digital I/O

Data Rate Up to 1MBaud
CPU 80C167
DPRAM 2kBytes

Includes 'C' Library of Driver Software
Absolute and Relative Moves, Jog, Home Sequence, Master/Slave

Australia	Melbourne
Austria	Vienna
Brazil	São Paulo
Denmark	Birkerød
England	Tewkesbury
Finland	Espoo
France	Rungis



Germany	Böblingen
Hong Kong	Kwai Chung
India	Bangalore
Ireland	Ringaskiddy
Italy	Malnate
Japan	Hiratsuka
Korea	Kwangju
Philippines	Baguio
Russia	Pavlovo
Singapore	Singapore
Spain	Orio
Sweden	Göteborg
USA	East Aurora (NY)

MOOG Controls Limited
Ashchurch
Tewkesbury
Gloucestershire
GL 20 8NA
Telephone (0 16 84) 29 66 00
Telefax (0 16 84) 29 67 60

MOOG GmbH
Hanns-Klemm-Straße 28
D - 71034 Böblingen
Postfach 1670
D - 71006 Böblingen
Telefon (0 70 31) 6 22 - 0
Telefax (0 70 31) 6 22 - 191

T161 / T164 - E / Rev1. / 04.97