

# EXPLOSION PROOF DYNAMIC BRUSHLESS SERVO MOTORS

ExD SERIES

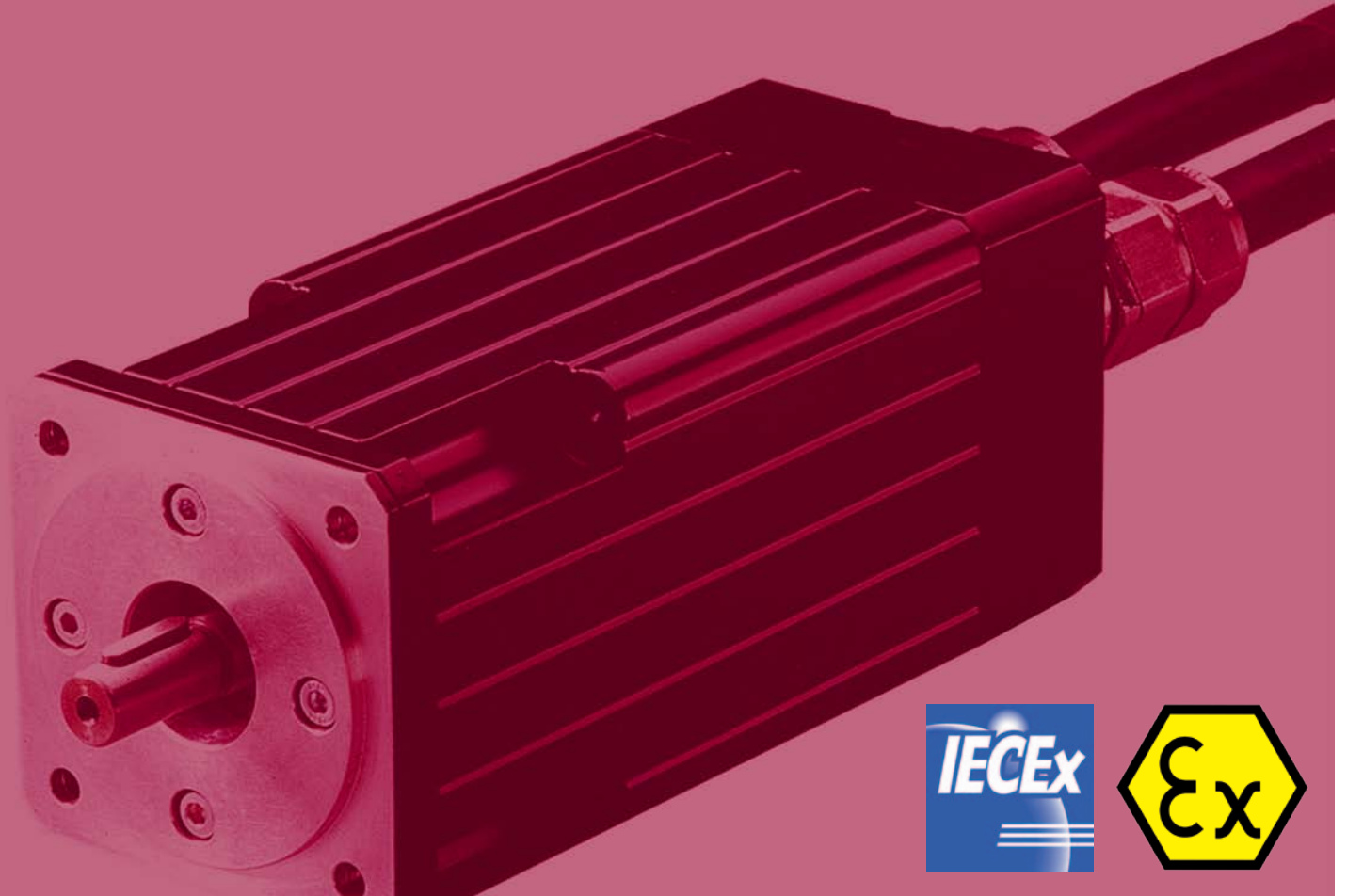

Rev. A, October 2011

OFFERING FULLY CERTIFIED SERVO MOTORS FOR USE IN POTENTIALLY EXPLOSIVE ATMOSPHERE IN ACCORDANCE WITH ATEX AND IECEX

Whenever the highest levels of motion control performance and design flexibility are required, you'll find Moog expertise at work. Through collaboration, creativity and world-class technological solutions, we help you overcome your toughest engineering obstacles. Enhance your machine's performance. And help take your thinking further than you ever thought possible.

INTRODUCTION.....	2	BACKGROUND.....	29
Product Overview .....	3	Application Note.....	29
Features and Benefits.....	5	About Moog.....	31
Technical Features.....	6	ORDERING INFORMATION .....	33
TECHNICAL DATA .....	9	Options .....	33
Size 3 - Low Voltage 325 VDC, Type G-3LM.....	9	Ordering Code.....	34
Size 3 - High Voltage 565 VDC, Type G-3LV .....	12		
Size 3 - Motor Characteristics T4 40 °C.....	15		
Size 3 - Type G-3L Dimensions.....	17		
Size 5 - Low Voltage 325 VDC, Type G-5LM.....	18		
Size 5 - High Voltage 565 VDC, Type G-5LV .....	21		
Size 5 - Motor Characteristics T4 40 °C.....	24		
Size 5 - Type G-5L Dimensions.....	26		
Wiring Diagram.....	27		
Bearing Load Diagrams.....	28		

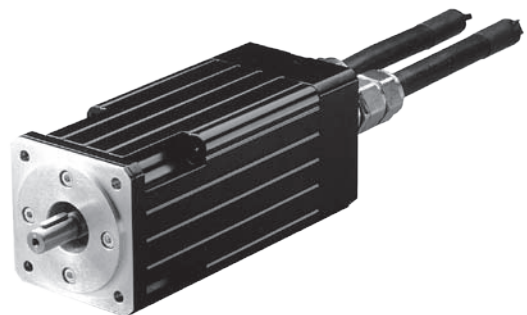

This catalog is for users with technical knowledge. To ensure that all necessary characteristics for function and safety of the system are given, the user has to check the suitability of the products described herein. The products described herein are subject to change without notice. In case of doubt, please contact Moog. For the most current information, visit [www.moog.com/products/motors-servomotors/](http://www.moog.com/products/motors-servomotors/). Moog is a registered trademark of Moog Inc. and its subsidiaries. All trademarks as indicated herein are the property of Moog Inc. and its subsidiaries. For the full disclaimer refer to [www.moog.com/literature/disclaimers](http://www.moog.com/literature/disclaimers).

For the most current information, visit [www.moog.com/industrial](http://www.moog.com/industrial) or contact your local Moog office.

©Moog Inc. 2011. All rights reserved. All changes are reserved.

## PRODUCT OVERVIEW

### Moog Brushless Technology

For over two decades, the name Moog has been associated with brushless servo motors and servo drives offering the highest dynamics, power density and reliability. The products are designed as a system to deliver superior servo performance. Moog offers a broad range of standard models as well as custom solutions to meet your unique application requirements. Moog brushless servo motors and drives are found on a variety of applications; especially where dynamics, compact size and reliability are important.

### ExD Series Servo Motors

Moog's Explosion Proof Dynamic Brushless Servo Motors (ExD Series) are electronically commutated synchronous AC motors with permanent magnet field excitation. The ExD Series Servo Motors are designed for highly dynamic servo applications where positioning times of 30 ms or less are often the norm. The ExD Series Servo Motors offers one of the industry's widest power ranges.

The modular design is supported by a variety of options with Moog's application staff capable of supplying fully customized solutions. All Moog Servo Motors are manufactured in-house and the use of tight machining tolerances, precision balancing and thorough production testing guarantee a long service life.

The ExD Series Motors are designed and tested for operation in conditions where vapors or gasses form flammable or explosive environments. The flameproof housing has proven capable to withstanding internal explosions without bursting or allowing ignition to reach outside the motor frame. These fully certified servo motors are for use in potentially explosive atmosphere in accordance with ATEX 94/9/CE directive "D" type protection and IECEx for II C gases, with dust protection against III C.

Please refer to the Modular Multi-axis Programmable Motion Control Servo Drive [catalog](#) for details of our Servo Drive offering.

### Standards

These motors are in compliance with ATEX and IECEx standard.

IEC 60079-0  
Explosive atmospheres  
- Part 0: Equipment - General requirements

IEC 60079-1  
Explosive atmospheres  
- Part 1: Equipment protection by flameproof enclosures "d"

IEC 60079-31  
Explosive atmospheres  
- Part 31: Equipment dust ignition protection by enclosure "t"

### Type of Protection

Flameproof "d", Dust "tb"

### Marking

Ex d IIC T4-T6 Gb Ex tb IIIC T 135 °C to T 85 °C Db  
IP 65/67

### Reference links

[ATEX Certificate](#)

[IECEx Certificate](#)

## PRODUCT OVERVIEW

Motor Type <sup>1)</sup>	Stall torque	Maximum torque	Nominal speed	Inertia	Square flange
	[Nm (lbf in)]	[Nm (lbf in)]	[r/min]	[kg cm <sup>2</sup> (10 <sup>-4</sup> lbf in s <sup>2</sup> )]	[mm (in)]
G-3LM2 (L05)	0.52 (4.6)	1.60 (14.2)	7,800	0.16 (1.4)	70 (2.76)
G-3LV2 (L05)					
G-3LM4 (L15)	1.39 (12.3)	4.90 (43.4)	6,300	0.39 (3.5)	70 (2.76)
G-3LV4 (L15)					
G-3LM6 (L25)	2.16 (19.1)	8.20 (72.6)	4,600	0.62 (5.5)	70 (2.76)
G-3LV6 (L25)					
G-3LM8 (L40)	3.26 (28.9)	13.20 (116.8)	3,800	0.97 (8.6)	70 (2.76)
G-3LV8 (L40)					
G-5LV2 (L10)	5.79 (51.2)	12.2 (108.0)	4,800	4.60 (40.7)	140 (5.51)
G-5LV2 (L10)					
G-5LM4 (L20)	10.83 (95.9)	25.80 (228.3)	3,500	8.00 (70.8)	140 (5.51)
G-5LV4 (L20)					
G-5LM6 (L30)	15.70 (139.0)	38.20 (338.1)	2,700	11.50 (101.8)	140 (5.51)
G-5LV6 (L30)					
G-5LM8 (L50)	25.40 (224.7)	61.20 (541.7)	2,000	18.4 (162.90)	140 (5.51)
G-5LV8 (L50)					

<sup>1)</sup> Motor type code [eg. G-3LM2 (L05)]  
 G = Explosion proof series servo motor  
 3 = Flange size  
 M = Winding voltage (M = Low voltage, 325 VDC with primary PTC thermal sensor)  
 V = Winding voltage (V = High voltage, 565 VDC with primary PTC thermal sensor)  
 2 (L05) = Stack length

### Notes:

1. Nominal speed can be easily adjusted by changing the stator windings. Please contact your local Moog application engineer for information.
2. All the above technical data is for explosion proof motor assuming T4 temperature class at 40 °C (104 °F).

## FEATURES AND BENEFITS

Features	Benefits
Protective system intend for use in potentially explosive atmosphere in accordance with ATEX 94/9/CE directive "d" type protection and IECEx for II C gasses with dust protection against III C	Certified product ideal for use in hazardous environments
Compact, light weight, high dynamic servo motor	Small footprint Energy Efficient Cost Effective
Brushless, low-cogging, rugged design	Minimum maintenance
Built-in PTC thermal sensor to protect motor from overheating under excessive loads	High safety
Bearings greased for life do not require maintenance	More machine uptime
Motor with feedback option of resolver and encoders, Optional holding brake, Cable gland optional	Modularity for a more flexible machine design
Protection class IP65/67	Higher safety

## TECHNICAL FEATURES

### Superior Motor Dynamics Improves Cycle Time

The ExD Series Servo Motor combines a low inertia rotor with an electromagnetic design having exceptional overload capacity. The result is an increase in the effective torque available to accelerate and decelerate the load, enabling higher dynamics and improved cycle times.

ExD Series Servo Motors use a fully laminated, weight-optimized, rotor to provide a significant inertia reduction over conventional solid rotor designs. It is able to achieve a high overload capacity through the use of high-energy rare magnets, a high pole count electrical design, and an efficient thermal construction.

### Compact and Lightweight Construction Simplifies Machine Design

The ExD Series Servo Motor provides high torque in a compact and lightweight package to achieve both high power density and a high torque-to-weight ratio. The compact and lightweight package provides greater flexibility and often enables new cost-saving approaches to machine construction. In applications where the motor is mounted on a moving axis, the high torque-to-weight ratio allows greater payloads and/or increased acceleration.

ExD Series Servo Motors leverage an all-aluminum motor housing to achieve a significant weight reduction over low cost steel housings. A robust thermal design allows more power to be designed into a small, compact, package.

### Proprietary, Low-Cogging Design Delivers Smooth Low Speed Operation

The ExD Series Servo Motor includes several design enhancements to deliver smooth slow speed performance. The enhancements include the selection of a high pole count (8 to 12 poles) electromagnetic design, a stator with non-symmetric slot count and other proprietary features to minimize cogging.

### Ruggedized, Maintenance-Free Design to Boost Overall System Availability

The ExD Series Servo Motor is designed and manufactured in accordance with strict CE (VDE) standards, using ruggedized components with proven reliability in harsh thermal and shock load environments. These features combine to offer years of reliable, maintenance-free, operations and boost overall system availability. The use of high-reliability feedback devices, sealed lifetime lubricated bearings, precision balanced rotors (Class G 6.3 of ISO 1940 and IP65 construction combine to extend service life.

### Flexible Design Option Eases Integration

The ExD Series Servo Motor is available with the following options:

- Integral holding brakes
- Resolver or encoder-based feedback
- Plain or slot and key type shafts
- Cable gland with cable

### Fully Customized Designs Support Unique Application Requirements

The Moog ExD Series Servo Motors can be customized to meet your unique needs.

The following are some common requests supported by Moog's application staff:

- Custom motor windings
- Custom shafts and flanges
- Custom feedback devices

## TECHNICAL FEATURES

### Moog Motor Performance Characteristics

With experience in a variety of industrial machinery applications, Moog’s engineers understand the critical role that application sizing process plays in overall machine design. With global competition forcing machine designers to do more with less, there is an expanding need to avoid unnecessary margin and “size” the motors exactly to your application needs. It is for these reasons that Moog specifies motor performance characteristics in a practical manner ideal for designing your system. Motor characteristics are specified under the same environmental conditions in which they will be used, with notes clearly articulating the operating conditions.

The motor performance characteristics contain three elements. The first element is the continuous torque curve. This curve illustrates the motor torque available at 100 % duty cycle under the following conditions:

- Operation in still air with ambient temperatures based on T code
- Motor front flange attached to a steel mounting plate measuring 300 x 300 x 12 mm (11.81 x 11.81 x 0.47 in)

The second element is the peak torque curve. This curve reflects the motor torque available with a 10 % duty cycle (1 out of 10 seconds). It is based on years of practical industry experience and is useful for typical servo applications.

The third element is the motor  $k_T$  characteristic. The motor  $k_T$  characteristic depicts stator saturation at various operating points and can be used to optimize sizing in low duty cycle applications. ExD Series Servo Motors can deliver a low duty cycle “impulse torque” which is typically 20 to 30 % more than rated peak torque. While motors can be operated reliably at this operating point, it is recommended that a member of Moog’s application team reviews the application to ensure thermal restrictions are not violated.

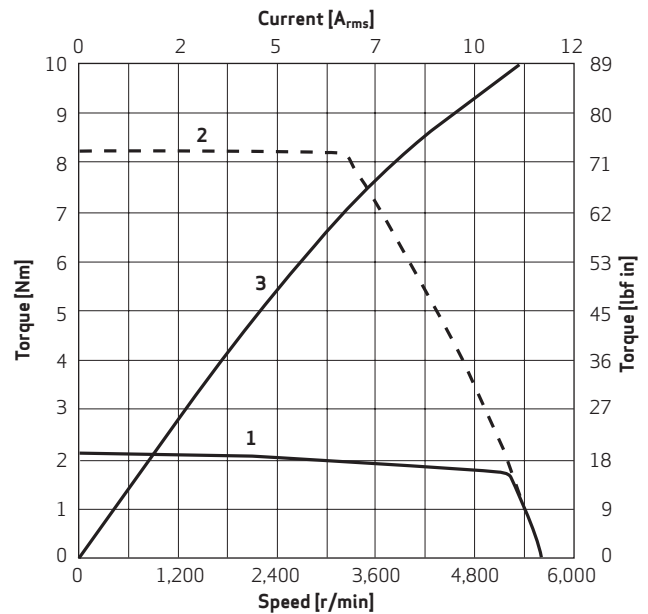

- 1 Continuous torque
- 2 Maximum torque
- 3 Torque constant  $k_T$

## TECHNICAL FEATURES

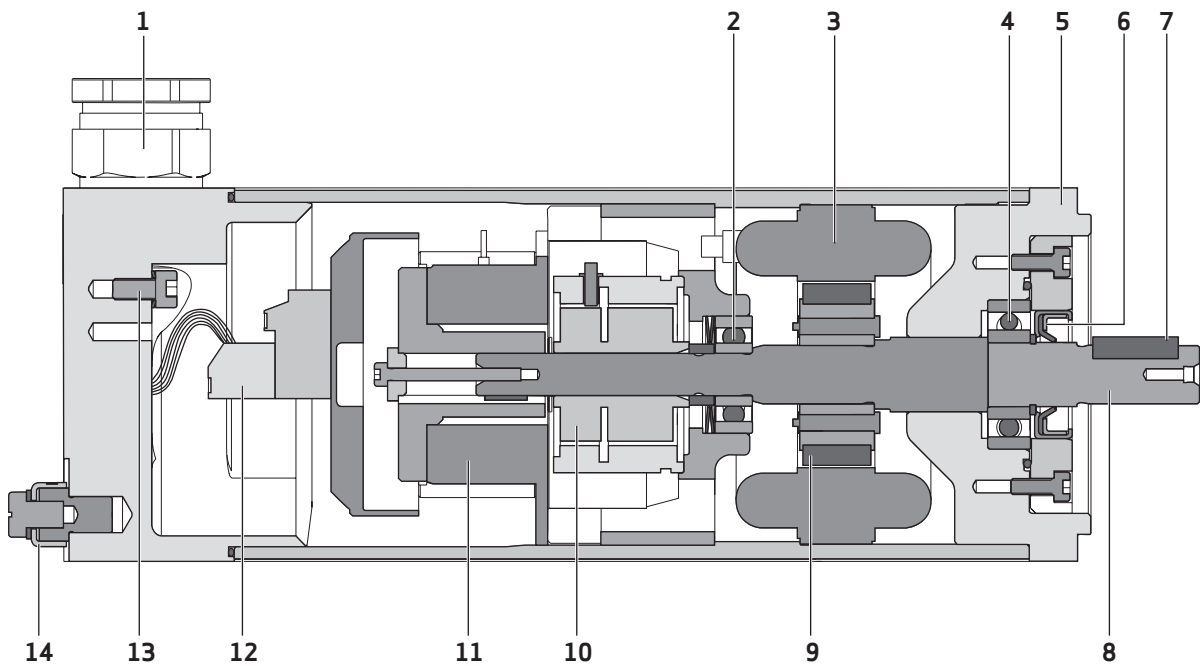

- 1 Cable outlet
- 2 Shaft bearing B (floating bearing)
- 3 Stator winding
- 4 Shaft bearing A (fixed bearing)
- 5 Flange
- 6 Radial shaft seal
- 7 Keyway (optional)
- 8 Shaft
- 9 Permanent magnets, rotor
- 10 Feedback device
- 11 Permanent magnet holding brake (optional)
- 12 Connection strip
- 13 Internal ground terminal
- 14 External ground terminal

**SIZE 3****Low Voltage 325 V<sub>DC</sub>, Type G-3LM****General characteristics**

Type		G-3LM2 (L05)	G-3LM4 (L15)	G-3LM6 (L25)	G-3LM8 (L40)	Units
Maximum torque	M <sub>max</sub>	1.6 (14.2)	4.9 (43.4)	8.2 (72.6)	13.2 (116.8)	Nm (lbf in)
Maximum current	I <sub>max</sub>	4.6	10.7	12.3	16.3	A <sub>rms</sub>
Maximum speed	n <sub>max</sub>	10,100	8,000	5,500	4,500	r/min
Torque constant	k <sub>T</sub>	0.39 (3.5)	0.52 (4.6)	0.76 (6.7)	0.92 (8.2)	Nm/A <sub>rms</sub> (lbf in/A <sub>rms</sub> )
Voltage constant	k <sub>e</sub>	25.0	31.6	45.7	55.3	V <sub>rms</sub> /k <sub>r/min</sub>
Thermal time constant	t <sub>th</sub>	350	760	970	1350	s
Winding resistance at 25 °C (77 °F) (phase to phase)	R <sub>tt</sub>	16.67	4.97	5.24	4.24	Ohm
Winding inductance (phase to phase)	L <sub>tt</sub>	19.4	8.5	10.1	8.9	mH
Rotor inertia with resolver	J	0.16 (1.4)	0.39 (3.5)	0.62 (5.5)	0.97 (8.6)	kg cm <sup>2</sup> (lbf in s <sup>2</sup> × 10 <sup>-4</sup> )
Rotor inertia with encoder	J	0.14 (1.2)	0.37 (3.3)	0.60 (5.3)	0.95 (8.4)	kg cm <sup>2</sup> (lbf in s <sup>2</sup> × 10 <sup>-4</sup> )
Weight (without brake)	m	2.1 (4.6)	2.7 (5.9)	3.3 (7.3)	4.2 (9.2)	kg (lb)

**SIZE 3****Low Voltage 325 V<sub>DC</sub>, Type G-3LM****Characteristics based on temperature class T4**

Type		G-3LM2 (L05)	G-3LM4 (L15)	G-3LM6 (L25)	G-3LM8 (L40)	Units
Continuous stall torque at 40 °C (104 °F)	M <sub>o</sub>	0.52 (4.6)	1.39 (12.3)	2.16 (19.1)	3.26 (28.9)	Nm (lbf in)
Continuous stall current at 40 °C (104 °F)	I <sub>o</sub>	1.31	2.67	2.84	3.52	A <sub>rms</sub>
Nominal torque at 40 °C (104 °F)	M <sub>N</sub>	0.44 (3.9)	1.09 (9.6)	1.81 (16.0)	2.82 (25.0)	Nm (lbf in)
Nominal speed at 40 °C (104 °F)	n <sub>N</sub>	7,800	6,300	4,600	3,800	r/min
Output power, continuous duty, nominal speed at 40 °C (104 °F)	P <sub>N</sub>	0.359 (0.48)	0.719 (0.96)	0.871 (1.17)	1.122 (1.50)	kW (hp)
Continuous stall torque at 50 °C (122 °F)	M <sub>o</sub>	0.50 (4.4)	1.33 (11.8)	2.07 (18.3)	3.13 (27.7)	Nm (lbf in)
Nominal torque at 50 °C (122 °F)	M <sub>N</sub>	0.42 (3.7)	1.02 (9.0)	1.72 (15.2)	2.66 (23.5)	Nm (lbf in)
Nominal speed at 50 °C (122 °F)	n <sub>N</sub>	7,800	6,300	4,600	3,800	r/min
Output power, continuous duty, nominal speed at 50 °C (122 °F)	P <sub>N</sub>	0.343 (0.46)	0.673 (0.90)	0.828 (1.11)	1.058 (1.42)	kW (hp)
Continuous stall torque at 60 °C (140 °F)	M <sub>o</sub>	0.46 (4.1)	1.22 (10.8)	1.91 (16.9)	2.88 (25.5)	Nm (lbf in)
Nominal torque at 60 °C (140 °F)	M <sub>N</sub>	0.37 (3.3)	0.88 (7.8)	1.52 (13.5)	2.37 (21.0)	Nm (lbf in)
Nominal speed at 60 °C (140 °F)	n <sub>N</sub>	7,800	6,300	4,600	3,800	r/min
Output power, continuous duty, nominal speed at 60 °C (140 °F)	P <sub>N</sub>	0.302 (0.40)	0.580 (0.78)	0.732 (0.98)	0.943 (1.26)	kW (hp)
Continuous stall torque at 70 °C (158 °F)	M <sub>o</sub>	0.41 (3.6)	1.09 (9.6)	1.70 (15.0)	2.56 (22.7)	Nm (lbf in)
Nominal torque at 70 °C (158 °F)	M <sub>N</sub>	0.31 (2.7)	0.69 (6.1)	1.25 (11.1)	1.97 (17.4)	Nm (lbf in)
Nominal speed at 70 °C (158 °F)	n <sub>N</sub>	7,800	6,300	4,600	3,800	r/min
Output power, continuous duty, nominal speed at 70 °C (158 °F)	P <sub>N</sub>	0.253 (0.34)	0.455 (0.61)	0.602 (0.81)	0.783 (1.05)	kW (hp)
Continuous stall torque at 80 °C (176 °F)	M <sub>o</sub>	0.34 (3.0)	0.91 (8.1)	1.41 (12.5)	2.14 (18.9)	Nm (lbf in)
Nominal torque at 80 °C (176 °F)	M <sub>N</sub>	0.22 (1.9)	0.35 (3.1)	0.83 (7.3)	1.38 (12.2)	Nm (lbf in)
Nominal speed at 80 °C (176 °F)	n <sub>N</sub>	7,800	6,300	4,600	3,800	r/min
Output power, continuous duty, nominal speed at 80 °C (176 °F)	P <sub>N</sub>	0.180 (0.24)	0.231 (0.31)	0.400 (0.54)	0.549 (0.74)	kW (hp)

**SIZE 3****Low Voltage 325 V<sub>DC</sub>, Type G-3LM****Characteristics based on temperature class T5**

Type		G-3LM2 (L05)	G-3LM4 (L15)	G-3LM6 (L25)	G-3LM8 (L40)	Units
Continuous stall torque at 40 °C (104 °F)	M <sub>o</sub>	0.43 (3.8)	1.17 (10.4)	1.81 (16.0)	2.74 (24.3)	Nm (lbf in)
Nominal torque at 40 °C (104 °F)	M <sub>N</sub>	0.33 (2.9)	0.75 (6.6)	1.35 (11.9)	2.12 (18.8)	Nm (lbf in)
Nominal speed at 40 °C (104 °F)	n <sub>N</sub>	7800	6300	4600	3800	r/min
Output power, continuous duty, nominal speed at 40 °C (104 °F)	P <sub>N</sub>	0.269 (0.36)	0.495 (0.66)	0.650 (0.87)	0.843 (1.13)	kW (hp)

**Characteristics based on temperature class T6**

Type		G-3LM2 (L05)	G-3LM4 (L15)	G-3LM6 (L25)	G-3LM8 (L40)	Units
Continuous stall torque at 40 °C (104 °F)	M <sub>o</sub>	0.32 (2.8)	0.85 (7.5)	1.32 (11.7)	1.99 (17.6)	Nm (lbf in)
Nominal torque at 40 °C (104 °F)	M <sub>N</sub>	0.14 (1.2)	0.59 (5.2)	0.45 (4.0)	0.91 (8.1)	Nm (lbf in)
Nominal speed at 40 °C (104 °F)	n <sub>N</sub>	7800	4000	4600	3800	r/min
Output power, continuous duty, nominal speed at 40 °C (104 °F)	P <sub>N</sub>	0.114 (0.15)	0.247 (0.33)	0.217 (0.29)	0.362 (0.49)	kW (hp)

**SIZE 3****High Voltage 565 V<sub>DC</sub>, Type G-3LV****General characteristics**

Type		G-3LV2 (L05)	G-3LV4 (L15)	G-3LV6 (L25)	G-3LV8 (L40)	Units
Maximum torque	M <sub>max</sub>	1.6 (14.2)	4.9 (43.4)	8.2 (72.6)	13.2 (116.8)	Nm (lbf in)
Maximum current	I <sub>max</sub>	3.8	7.9	8.0	12.0	A <sub>rms</sub>
Maximum speed	n <sub>max</sub>	14,400	10,100	6,100	5,700	r/min
Torque constant	k <sub>T</sub>	0.47 (4.2)	0.71 (6.3)	1.18 (10.4)	1.27 (11.2)	Nm/A <sub>rms</sub> (lbf in/A <sub>rms</sub> )
Voltage constant	k <sub>e</sub>	30.0	43.3	71.0	75.9	V <sub>rms</sub> /k <sub>r/min</sub>
Thermal time constant	t <sub>th</sub>	350	760	970	1350	s
Winding resistance at 25 °C (77 °F) (phase to phase)	R <sub>tt</sub>	24.56	9.53	13.0	8.09	Ohm
Winding inductance (phase to phase)	L <sub>tt</sub>	29.3	15.9	24.7	16.8	mH
Rotor inertia with resolver	J	0.16 (1.4)	0.39 (3.5)	0.62 (5.5)	0.97 (8.6)	kg cm <sup>2</sup> (lbf in s <sup>2</sup> x 10 <sup>-4</sup> )
Rotor inertia with encoder	J	0.14 (1.2)	0.37 (3.3)	0.60 (5.3)	0.95 (8.4)	kg cm <sup>2</sup> (lbf in s <sup>2</sup> x 10 <sup>-4</sup> )
Weight (without brake)	m	2.1 (4.6)	2.7 (5.9)	3.3 (7.3)	4.2 (9.2)	kg (lb)

## SIZE 3

High Voltage 565 V<sub>DC</sub>, Type G-3LV

## Characteristics based on temperature class T4

Type		G-3LV2 (L05)	G-3LV4 (L15)	G-3LV6 (L25)	G-3LV8 (L40)	Units
Continuous stall torque at 40 °C (104 °F)	M <sub>o</sub>	0.52 (4.6)	1.39 (12.3)	2.16 (19.1)	3.26 (28.9)	Nm (lbf in)
Continuous stall current at 40 °C (104 °F)	I <sub>o</sub>	1.08	1.94	1.81	2.56	A <sub>rms</sub>
Nominal torque at 40 °C (104 °F)	M <sub>N</sub>	0.44 (3.9)	1.09 (9.6)	1.81 (16.0)	2.82 (25.0)	Nm (lbf in)
Nominal speed at 40 °C (104 °F)	n <sub>N</sub>	7,800	6,300	4,600	3,800	r/min
Output power, continuous duty, nominal speed at 40 °C (104 °F)	P <sub>N</sub>	0.359 (0.48)	0.719 (0.96)	0.871 (1.17)	1.122 (1.50)	kW (hp)
Continuous stall torque at 50 °C (122 °F)	M <sub>o</sub>	0.50 (4.4)	1.33 (11.8)	2.07 (18.3)	3.13 (27.7)	Nm (lbf in)
Nominal torque at 50 °C (122 °F)	M <sub>N</sub>	0.42 (3.7)	1.02 (9.0)	1.72 (15.2)	2.66 (23.5)	Nm (lbf in)
Nominal speed at 50 °C (122 °F)	n <sub>N</sub>	7,800	6,300	4,600	3,800	r/min
Output power, continuous duty, nominal speed at 50 °C (122 °F)	P <sub>N</sub>	0.343 (0.46)	0.673 (0.90)	0.828 (1.11)	1.058 (1.42)	kW (hp)
Continuous stall torque at 60 °C (140 °F)	M <sub>o</sub>	0.46 (4.1)	1.22 (10.8)	1.91 (16.9)	2.88 (25.5)	Nm (lbf in)
Nominal torque at 60 °C (140 °F)	M <sub>N</sub>	0.37 (3.3)	0.88 (7.8)	1.52 (13.5)	2.37 (21.0)	Nm (lbf in)
Nominal speed at 60 °C (140 °F)	n <sub>N</sub>	7,800	6,300	4,600	3,800	r/min
Output power, continuous duty, nominal speed at 60 °C (140 °F)	P <sub>N</sub>	0.302 (0.40)	0.580 (0.78)	0.732 (0.98)	0.943 (1.26)	kW (hp)
Continuous stall torque at 70 °C (158 °F)	M <sub>o</sub>	0.41 (3.6)	1.09 (9.6)	1.70 (15.0)	2.56 (22.7)	Nm (lbf in)
Nominal torque at 70 °C (158 °F)	M <sub>N</sub>	0.31 (2.7)	0.69 (6.1)	1.25 (11.1)	1.97 (17.4)	Nm (lbf in)
Nominal speed at 70 °C (158 °F)	n <sub>N</sub>	7,800	6,300	4,600	3,800	r/min
Output power, continuous duty, nominal speed at 70 °C (158 °F)	P <sub>N</sub>	0.253 (0.34)	0.455 (0.61)	0.602 (0.81)	0.783 (1.05)	kW (hp)
Continuous stall torque at 80 °C (176 °F)	M <sub>o</sub>	0.34 (3.0)	0.91 (8.1)	1.41 (12.5)	2.14 (18.9)	Nm (lbf in)
Nominal torque at 80 °C (176 °F)	M <sub>N</sub>	0.22 (1.9)	0.35 (3.1)	0.83 (7.3)	1.38 (12.2)	Nm (lbf in)
Nominal speed at 80 °C (176 °F)	n <sub>N</sub>	7,800	6,300	4,600	3,800	r/min
Output power, continuous duty, nominal speed	P <sub>N</sub>	0.180 (0.24)	0.231 (0.31)	0.400 (0.54)	0.549 (0.74)	kW (hp)

**SIZE 3****High Voltage 565 V<sub>DC</sub>, Type G-3LV****Characteristics based on temperature class T5**

Type		G-3LV2 (L05)	G-3LV4 (L15)	G-3LV6 (L25)	G-3LV8 (L40)	Units
Continuous stall torque at 40 °C (104 °F)	M <sub>o</sub>	0.43 (3.8)	1.17 (10.4)	1.81 (16.0)	2.74 (24.3)	Nm (lbf in)
Nominal torque at 40 °C (104 °F)	M <sub>N</sub>	0.33 (2.9)	0.75 (6.6)	1.35 (11.9)	2.12 (18.8)	Nm (lbf in)
Nominal speed at 40 °C (104 °F)	n <sub>N</sub>	7,800	6,300	4,600	3,800	r/min
Output power, continuous duty, nominal speed at 40 °C (104 °F)	P <sub>N</sub>	0.269 (0.36)	0.495 (0.66)	0.650 (0.87)	0.843 (1.13)	kW (hp)

**Characteristics based on temperature class T6**

Type		G3LV2 (L05)	G3LV4 (L15)	G3LV6 (L25)	G3LV8 (L40)	Units
Continuous stall torque at 40 °C (104 °F)	M <sub>o</sub>	0.32 (2.8)	0.85 (7.5)	1.32 (11.7)	1.99 (17.6)	Nm (lbf in)
Nominal torque at 40 °C (104 °F)	M <sub>N</sub>	0.14 (1.2)	0.59 (5.2)	0.45 (4.0)	0.91 (8.1)	Nm (lbf in)
Nominal speed at 40 °C (104 °F)	n <sub>N</sub>	7800	4000	4600	3800	r/min
Output power, continuous duty, nominal speed at 40 °C (104 °F)	P <sub>N</sub>	0.114 (0.15)	0.247 (0.33)	0.217 (0.29)	0.362 (0.49)	kW (hp)

# SIZE 3

## Motor Characteristics Type G-3L

Temperature class T4  
 Ambient temperature 40 °C (104 °F)

**G-3LM2 (L05)**

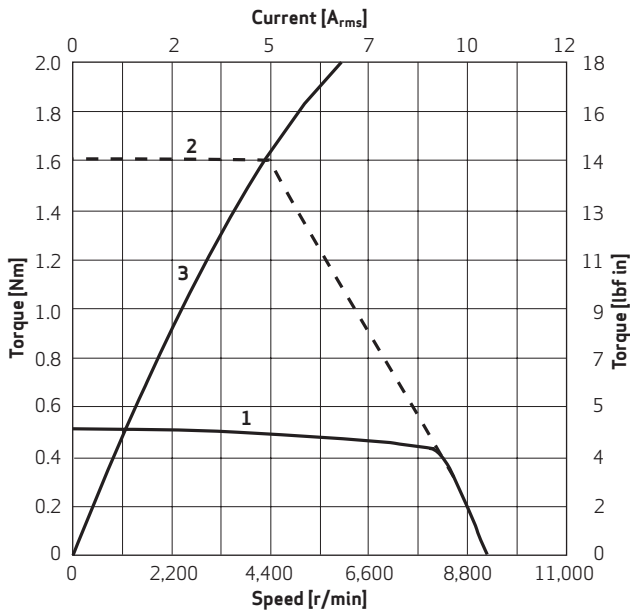

**G-3LV2 (L05)**

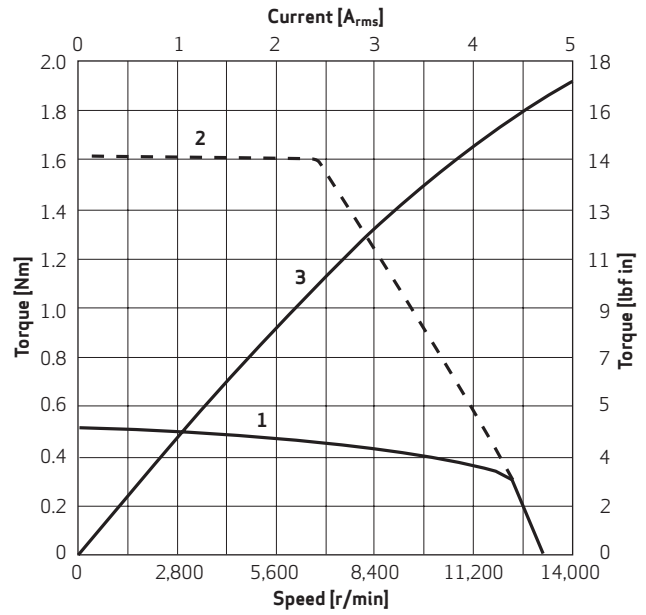

**G-3LM4 (L15)**

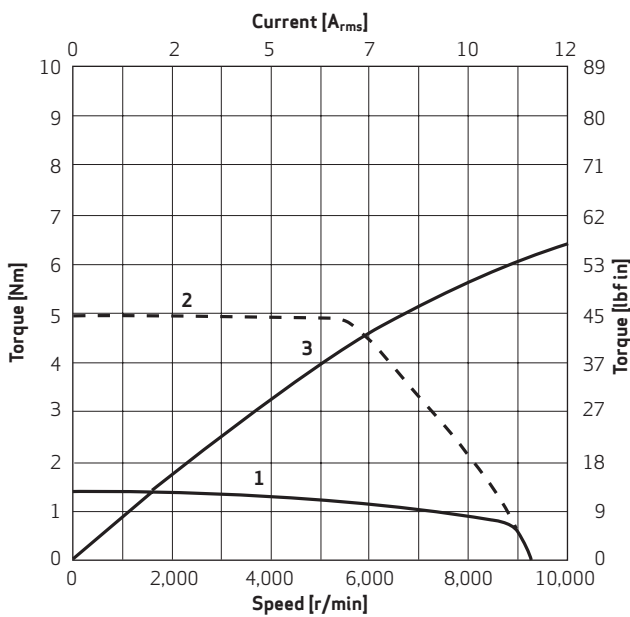

**G-3LV4 (L15)**

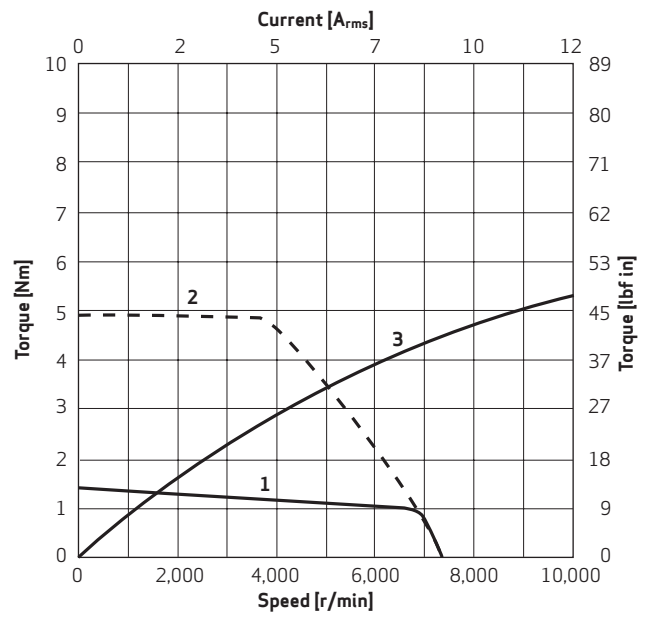

1 Continuous torque    2 Maximum torque    3 Torque constant  $k_T$

# SIZE 3

## Motor Characteristics Type G-3L

Temperature class T4

Ambient temperature 40 °C (104 °F)

### G-3LM6 (L05)

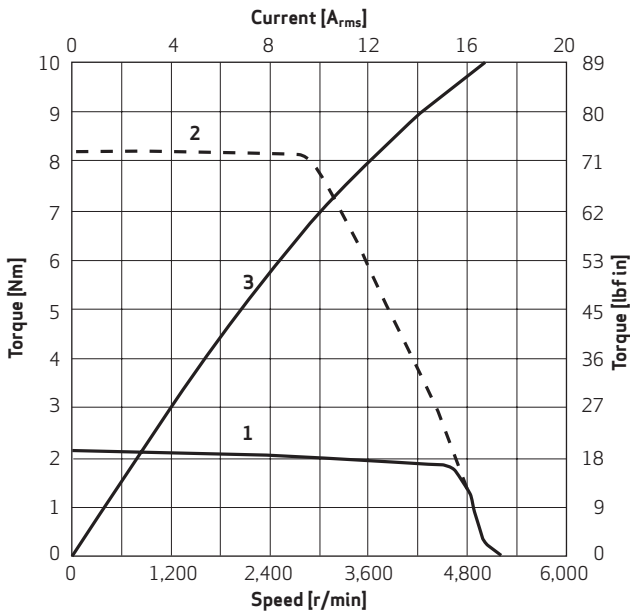

### G-3LV6 (L05)

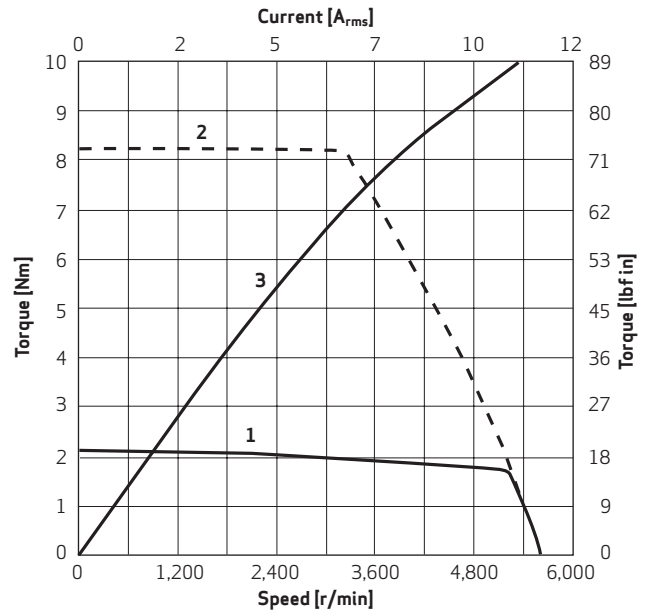

### G-3LM8 (L15)

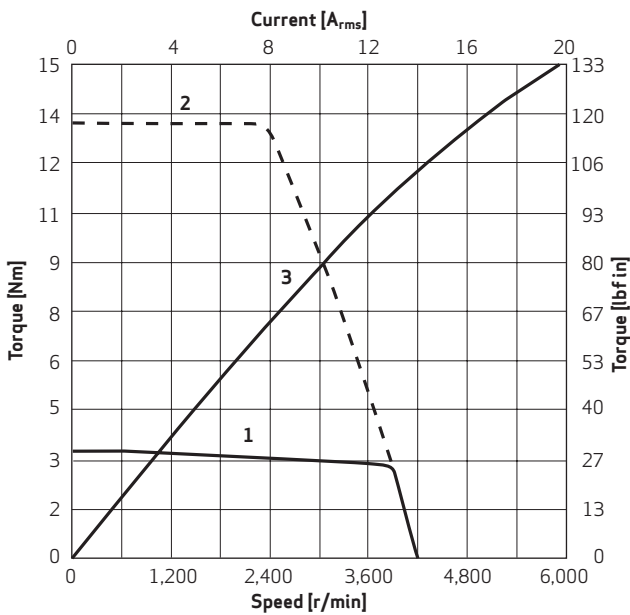

### G-3LV8 (L15)

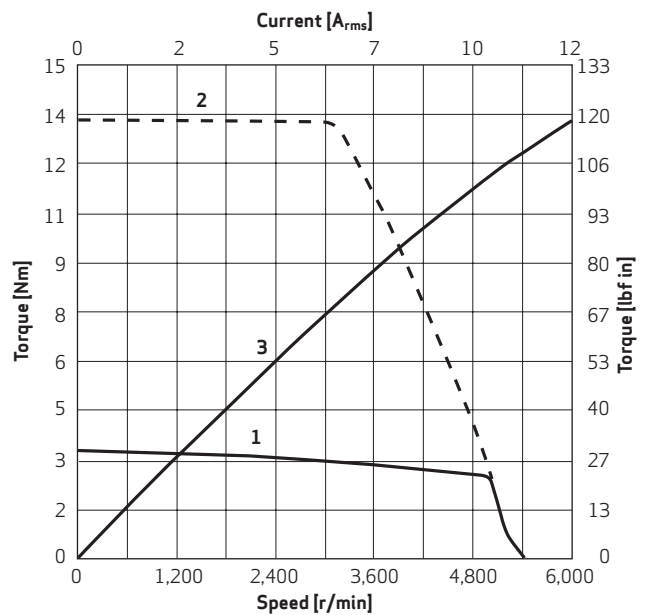

1 Continuous torque    2 Maximum torque    3 Torque constant  $k_T$

# SIZE 3

## Type G-3L, Dimensions

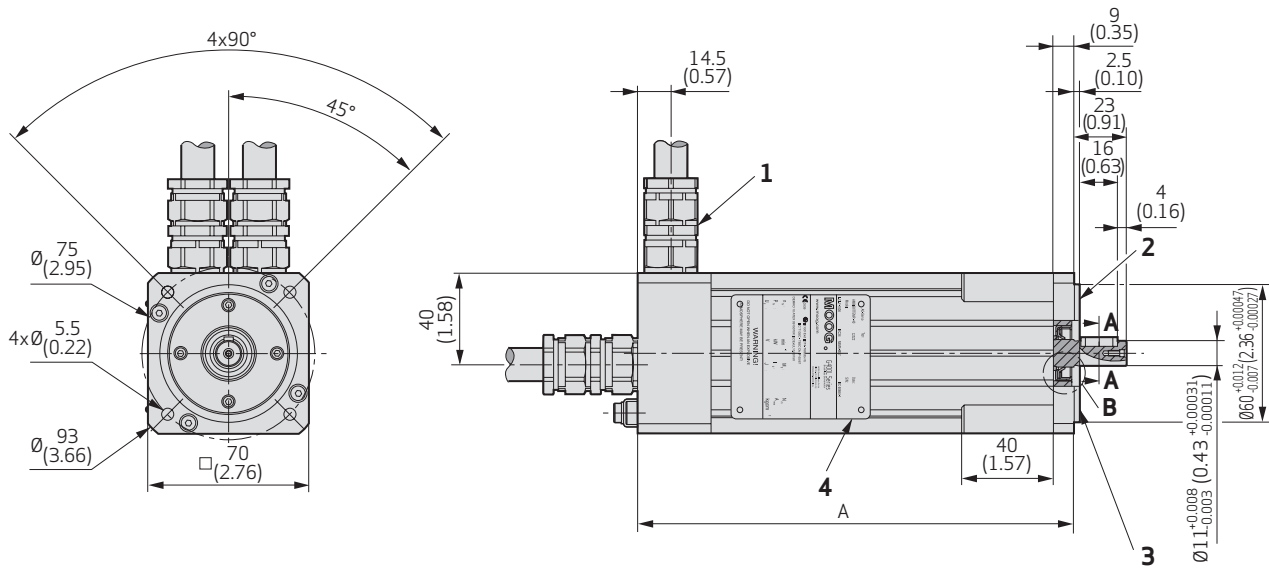

**Section A-A**

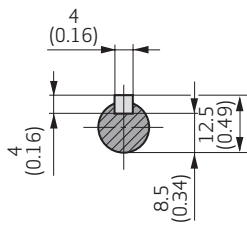

**Detail B**

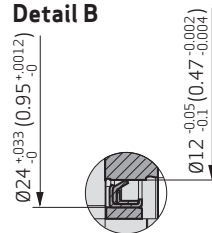

**Cable Gland**

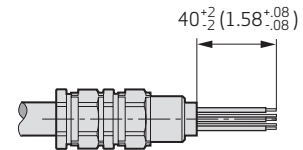

**Sectional view for connection cable**

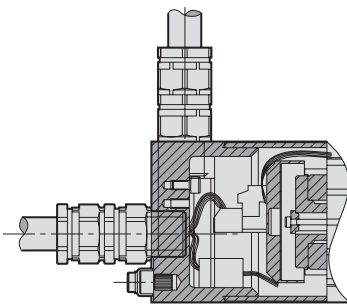

- 1 Alternative cable outlet
- 2 Tolerance of shaft extension run out and mounting flange DIN 42955
- 3 Flange IEC 34 DIN 42948
- 4 Name plate

Motor Length	Dimension "A"	Dimension "A"
[mm (in)]	- Resolver with brake - Encoder without brake	- Resolver without brake
L05	190 (7.48)	164 (6.45)
L15	215.5 (8.48)	189.5 (7.46)
L25	241 (9.48)	215 (8.46)
L40	279 (10.99)	253 (9.96)

**Note:**  
NEMA/IEC metric mounting

## SIZE 5

### Low Voltage 325 V<sub>DC</sub>, Type G-5LM

#### General characteristics

Type		G-5LM2 (L10)	G-5LM4 (L20)	G-5M6 (L30)	G-5LM8 (L50)	Units
Maximum torque	M <sub>max</sub>	12.2 (108.0)	25.8 (228.3)	38.2 (338.1)	61.2 (541.7)	Nm (lbf in)
Maximum current	I <sub>max</sub>	24.2	33.0	38.1	43.3	A <sub>rms</sub>
Maximum speed	n <sub>max</sub>	6,600	4,100	3,300	2,400	r/min
Torque constant	k <sub>T</sub>	0.62 (5.5)	1.00 (8.9)	1.28 (11.3)	1.74 (15.4)	Nm/A <sub>rms</sub> (lbf in/A <sub>rms</sub> )
Voltage constant	k <sub>e</sub>	38.3	60.5	76.5	104.0	V <sub>rms</sub> /k <sub>r/min</sub>
Thermal time constant	t <sub>th</sub>	1,590	2,200	2,540	3,300	s
Winding resistance at 25 °C (77 °F) (phase to phase)	R <sub>tt</sub>	0.876	0.760	0.659	0.576	Ohm
Winding inductance (phase to phase)	L <sub>tt</sub>	4.0	4.4	4.5	5.0	mH
Rotor inertia with resolver	J	4.60 (40.7)	8.00 (70.8)	11.50 (101.8)	18.40 (162.9)	kg cm <sup>2</sup> (lbf in s <sup>2</sup> x 10 <sup>-4</sup> )
Rotor inertia with encoder	J	4.40 (38.9)	7.80 (69.0)	11.30 (100.0)	18.20 (161.1)	kg cm <sup>2</sup> (lbf in s <sup>2</sup> x 10 <sup>-4</sup> )
Weight (without brake)	m	12.1 (26.7)	14.3 (31.5)	16.5 (36.4)	21.0 (46.3)	kg (lb)

**SIZE 5****Low Voltage 325 V<sub>DC</sub>, Type G-5LM****Characteristics based on temperature class T4**

Type		G-5LM2 (L10)	G-5LM4 (L20)	G-5LM6 (L30)	G-5LM8 (L50)	Units
Continuous stall torque at 40 °C (104 °F)	M <sub>o</sub>	5.79 (51.2)	10.83 (95.9)	15.70 (139.0)	25.4 (224.7)	Nm (lbf in)
Continuous stall current	I <sub>o</sub>	9.40	10.76	12.27	14.52	A <sub>rms</sub>
Nominal torque at 40 °C (104 °F)	M <sub>N</sub>	4.32 (38.2)	8.15 (72.1)	12.40 (109.7)	20.95 (185.4)	Nm (lbf in)
Nominal speed	n <sub>N</sub>	4,800	3,500	2,700	2,000	r/min
Output power, continuous duty, nominal speed	P <sub>N</sub>	2.170 (2.91)	2.985 (4.00)	3.504 (4.70)	4.385 (5.88)	kW (hp)
Continuous stall torque at 50 °C (122 °F)	M <sub>o</sub>	5.47 (48.4)	10.24 (90.6)	14.85 (131.4)	24.00 (212.4)	Nm (lbf in)
Nominal torque at 50 °C (122 °F)	M <sub>N</sub>	3.92 (34.7)	7.39 (65.4)	11.34 (100.4)	19.32 (171.0)	Nm (lbf in)
Nominal speed	n <sub>N</sub>	4,800	3,500	2,700	2,000	r/min
Output power, continuous duty, nominal speed	P <sub>N</sub>	1.969 (2.64)	2.707 (3.63)	3.204 (4.30)	4.044 (5.42)	kW (hp)
Continuous stall torque at 60 °C (140 °F)	M <sub>o</sub>	5.15 (45.6)	9.64 (85.3)	13.98 (123.7)	22.60 (200.0)	Nm (lbf in)
Nominal torque at 60 °C (140 °F)	M <sub>N</sub>	3.47 (30.7)	6.56 (58.1)	10.21 (90.4)	17.58 (155.6)	Nm (lbf in)
Nominal speed	n <sub>N</sub>	4,800	3,500	2,700	2,000	r/min
Output power, continuous duty, nominal speed	P <sub>N</sub>	1.743 (2.34)	2.403 (3.22)	2.885 (3.87)	3.680 (4.93)	kW (hp)
Continuous stall torque at 70 °C (158 °F)	M <sub>o</sub>	4.81 (42.6)	9.00 (79.7)	13.07 (115.7)	21.14 (187.1)	Nm (lbf in)
Nominal torque at 70 °C (158 °F)	M <sub>N</sub>	2.96 (26.2)	5.58 (49.4)	8.92 (78.9)	15.67 (138.7)	Nm (lbf in)
Nominal speed	n <sub>N</sub>	4,800	3,500	2,700	2,000	r/min
Output power, continuous duty, nominal speed	P <sub>N</sub>	1.487 (1.99)	2.044 (2.74)	2.521 (3.38)	3.280 (4.40)	kW (hp)
Continuous stall torque at 80 °C (176 °F)	M <sub>o</sub>	4.30 (38.1)	8.05 (71.2)	11.67 (103.3)	18.87 (167.0)	Nm (lbf in)
Nominal torque at 80 °C (176 °F)	M <sub>N</sub>	2.06 (18.2)	3.88 (34.3)	6.73 (59.6)	12.43 (110.0)	Nm (lbf in)
Nominal speed	n <sub>N</sub>	4,800	3,500	2,700	2,000	r/min
Output power, continuous duty, nominal speed	P <sub>N</sub>	1.035 (1.39)	1.421 (1.91)	1.902 (2.55)	2.602 (3.49)	kW (hp)

**SIZE 5****Low Voltage 325 V<sub>DC</sub>, Type G-5LM****Characteristics based on temperature class T5**

Type		G-5LM2 (L10)	G-5LM4 (L20)	G-5LM6 (L30)	G-5LM8 (L50)	Units
Continuous stall torque at 40 °C (104 °F)	M <sub>o</sub>	5.09 (45.1)	9.53 (84.3)	13.82 (122.3)	22.35 (197.8)	Nm (lbf in)
Nominal torque at 40 °C (104 °F)	M <sub>N</sub>	3.15 (27.9)	5.92 (52.4)	9.47 (83.8)	16.60 (146.9)	Nm (lbf in)
Nominal speed	n <sub>N</sub>	4,800	3,500	2,700	2,000	r/min
Output power, continuous duty, nominal speed	P <sub>N</sub>	1.582 (2.12)	2.169 (2.91)	2.676 (3.59)	3.475 (4.66)	kW (hp)

**Characteristics based on temperature class T6**

Type		G-5LM2 (L10)	G-5LM4 (L20)	G-5LM6 (L30)	G-5LM8 (L50)	Units
Continuous stall torque at 40 °C (104 °F)	M <sub>o</sub>	4.03 (35.7)	7.54 (66.7)	10.93 (96.7)	17.68 (156.5)	Nm (lbf in)
Nominal torque at 40 °C (104 °F)	M <sub>N</sub>	1.47 (13.0)	2.51 (22.2)	4.42 (39.1)	7.83 (69.3)	Nm (lbf in)
Nominal speed	n <sub>N</sub>	4,200	3,100	2,500	2,000	r/min
Output power, continuous duty, nominal speed	P <sub>N</sub>	0.646 (0.87)	0.814 (1.09)	1.156 (1.55)	1.639 (2.20)	kW (hp)

## SIZE 5

### High Voltage 565 V<sub>DC</sub>, Type G-5LV

#### General characteristics

Type		G-5LV2 (L10)	G-5LV4 (L20)	G-5LV6 (L30)	G-5LV8 (L50)	Units
Maximum torque	M <sub>max</sub>	12.20 (108.0)	25.80 (228.3)	38.20 (338.1)	61.20 (541.7)	Nm (lbf in)
Maximum current	I <sub>max</sub>	13.6	22.9	35.5	44.0	A <sub>rms</sub>
Maximum speed	n <sub>max</sub>	6,300	4,900	5,200	4,200	r/min
Torque constant	k <sub>T</sub>	1.11 (9.8)	1.45 (12.8)	1.38 (12.2)	1.74 (15.4)	Nm/A <sub>rms</sub> (lbf in/A <sub>rms</sub> )
Voltage constant	k <sub>e</sub>	69.4	88.4	83.5	104.0	V <sub>rms</sub> /k <sub>r/min</sub>
Thermal time constant	t <sub>th</sub>	1,590	2,200	2,540	3,300	s
Winding resistance at 25 °C (77 °F) (phase to phase)	R <sub>tt</sub>	2.850	1.595	0.757	0.576	Ohm
Winding inductance (phase to phase)	L <sub>tt</sub>	13.0	9.3	5.4	5.0	mH
Rotor inertia with resolver	J	4.60 (40.7)	8.00 (70.8)	11.50 (101.8)	18.40 (162.9)	kg cm <sup>2</sup> (lbf in s <sup>2</sup> x 10 <sup>-4</sup> )
Rotor inertia with encoder	J	4.40 (38.9)	7.80 (69.0)	11.30 (100.0)	18.20 (161.1)	kg cm <sup>2</sup> (lbf in s <sup>2</sup> x 10 <sup>-4</sup> )
Weight (without brake)	m	12.1 (26.7)	14.3 (31.5)	16.5 (36.4)	21.0 (46.3)	kg (lb)

## SIZE 5

High Voltage 565 V<sub>DC</sub>, Type G-5LV

## Characteristics based on temperature class T4

Type		G-5LV2 (L10)	G-5LV4 (L20)	G-5LV6 (L30)	G-5LV8 (L50)	Units
Continuous stall torque at 40 °C (104 °F)	M <sub>o</sub>	5.79 (51.2)	10.83 (95.9)	15.70 (139.0)	25.39 (224.7)	Nm (lbf in)
Continuous stall current	I <sub>o</sub>	5.16	7.40	11.35	14.52	A <sub>rms</sub>
Nominal torque at 40 °C (104 °F)	M <sub>N</sub>	4.32 (38.2)	8.15 (72.1)	12.40 (109.7)	20.95 (185.4)	Nm (lbf in)
Nominal speed	n <sub>N</sub>	4,800	3,500	2,700	2,000	r/min
Output power, continuous duty, nominal speed	P <sub>N</sub>	2.170 (2.91)	2.985 (4.00)	3.504 (4.70)	4.385 (5.88)	kW (hp)
Continuous stall torque at 50 °C (122 °F)	M <sub>o</sub>	5.47 (48.4)	10.24 (90.6)	14.85 (131.4)	24.00 (212.4)	Nm (lbf in)
Nominal torque at 50 °C (122 °F)	M <sub>N</sub>	3.92 (34.7)	7.39 (65.4)	11.34 (100.4)	19.32 (171.0)	Nm (lbf in)
Nominal speed	n <sub>N</sub>	4,800	3,500	2,700	2,000	r/min
Output power, continuous duty, nominal speed	P <sub>N</sub>	1.969 (2.64)	2.707 (3.63)	3.204 (4.30)	4.044 (5.42)	kW (hp)
Continuous stall torque at 60 °C (140 °F)	M <sub>o</sub>	5.15 (45.6)	9.64 (85.3)	13.98 (123.7)	22.60 (200.0)	Nm (lbf in)
Nominal torque at 60 °C (140 °F)	M <sub>N</sub>	3.47 (30.7)	6.56 (58.1)	10.21 (90.4)	17.58 (155.6)	Nm (lbf in)
Nominal speed	n <sub>N</sub>	4,800	3,500	2,700	2,000	r/min
Output power, continuous duty, nominal speed	P <sub>N</sub>	1.743 (2.34)	2.403 (3.22)	2.885 (3.87)	3.680 (4.93)	kW (hp)
Continuous stall torque at 70 °C (158 °F)	M <sub>o</sub>	4.81 (42.6)	9.00 (79.7)	13.07 (115.7)	21.14 (187.1)	Nm (lbf in)
Nominal torque at 70 °C (158 °F)	M <sub>N</sub>	2.96 (26.2)	5.58 (49.4)	8.92 (78.9)	15.67 (138.7)	Nm (lbf in)
Nominal speed	n <sub>N</sub>	4,800	3,500	2,700	2,000	r/min
Output power, continuous duty, nominal speed	P <sub>N</sub>	1.487 (1.99)	2.044 (2.74)	2.521 (3.38)	3.280 (4.40)	kW (hp)
Continuous stall torque at 80 °C (176 °F)	M <sub>o</sub>	4.30 (38.1)	8.05 (71.2)	11.67 (103.3)	18.87 (167.0)	Nm (lbf in)
Nominal torque at 80 °C (176 °F)	M <sub>N</sub>	2.06 (18.2)	3.88 (34.3)	6.73 (59.6)	12.43 (110.0)	Nm (lbf in)
Nominal speed	n <sub>N</sub>	4,800	3,500	2,700	2,000	r/min
Output power, continuous duty, nominal speed	P <sub>N</sub>	1.035 (1.39)	1.421 (1.91)	1.902 (2.55)	2.602 (3.49)	kW (hp)

**SIZE 5****High Voltage 565 V<sub>dc</sub>, Type G-5LV****Characteristics based on temperature class T5**

Type		G-5LV2 (L10)	G-5LV4 (L20)	G-5LV6 (L30)	G-5LV8 (L50)	Units
Continuous stall torque at 40 °C (104 °F)	M <sub>o</sub>	5.09 (45.1)	9.53 (84.3)	13.82 (122.3)	22.35 (197.8)	Nm (lbf in)
Nominal torque at 40 °C (104 °F)	M <sub>N</sub>	3.15 (27.9)	5.92 (52.4)	9.47 (83.8)	16.60 (146.9)	Nm (lbf in)
Nominal speed	n <sub>N</sub>	4,800	3,500	2,700	2,000	r/min
Output power, continuous duty, nominal speed	P <sub>N</sub>	1.582 (2.12)	2.169 (2.91)	2.676 (3.59)	3.475 (4.66)	kW (hp)

**Characteristics based on temperature class T6**

Type		G-5LV2 (L10)	G-5LV4 (L20)	G-5LV6 (L30)	G-5LV8 (L50)	Units
Continuous stall torque at 40 °C (104 °F)	M <sub>o</sub>	4.03 (35.7)	7.54 (66.7)	10.93 (96.7)	17.68 (156.5)	Nm (lbf in)
Nominal torque at 40 °C (104 °F)	M <sub>N</sub>	1.47 (13.0)	2.51 (22.2)	4.42 (39.1)	7.83 (69.3)	Nm (lbf in)
Nominal speed	n <sub>N</sub>	4,200	3,100	2,500	2,000	r/min
Output power, continuous duty, nominal speed	P <sub>N</sub>	0.646 (0.87)	0.814 (1.09)	1.156 (1.55)	1.639 (2.20)	kW (hp)

# SIZE 5

## Motor Characteristics Type G-5L

Temperature class T4

Ambient temperature 40 °C (104 °F)

### G-5LM2 (L10)

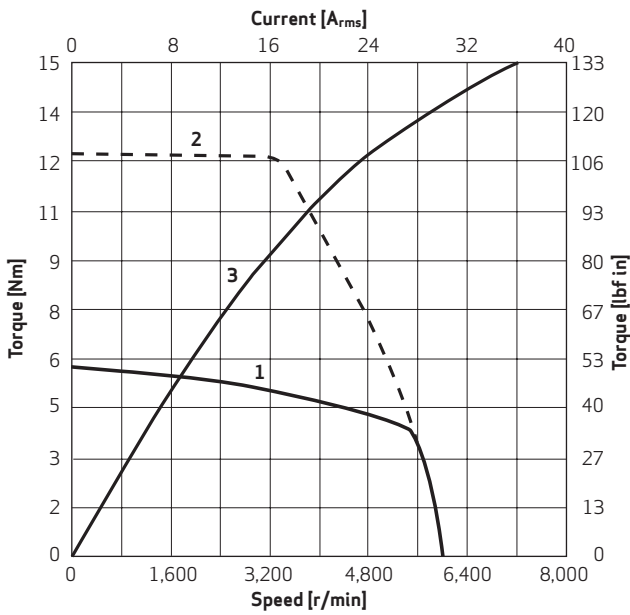

### G-5LV2 (L10)

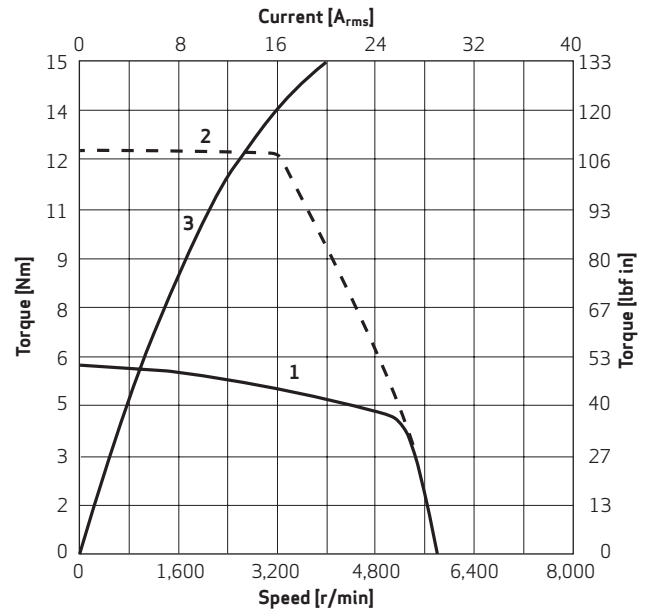

### G-5LM4 (L20)

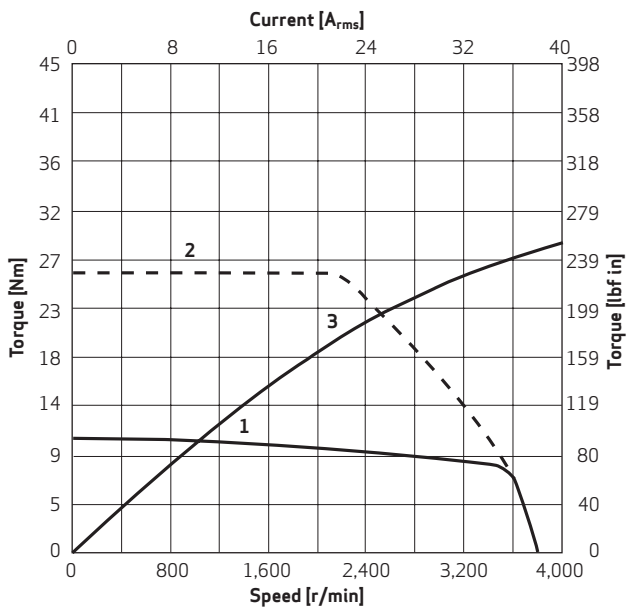

### G-5LV4 (L20)

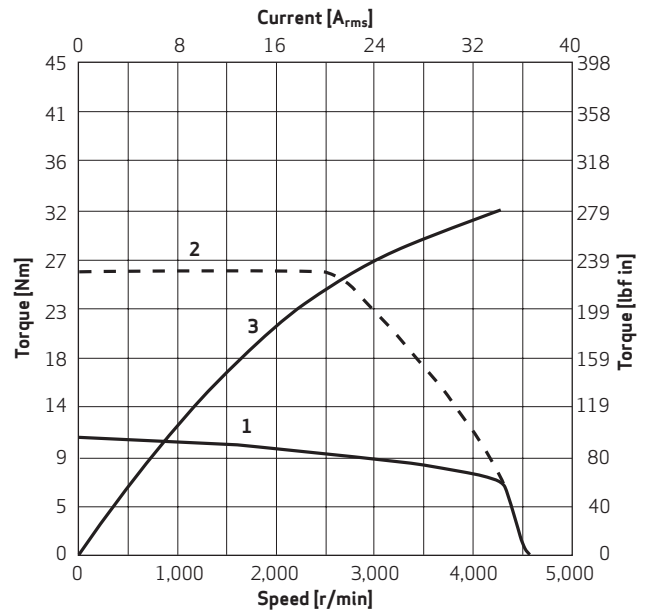

1 Continuous torque    2 Maximum torque    3 Torque constant k<sub>T</sub>

# SIZE 5

## Motor Characteristics Type G-5L

Temperature class T4  
 Ambient temperature 40 °C (104 °F)

**G-5LM6 (L30)**

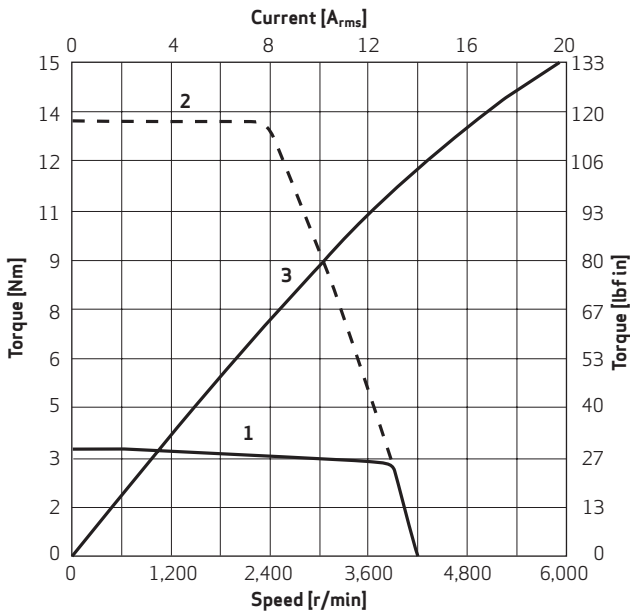

**G-5LV6 (L30)**

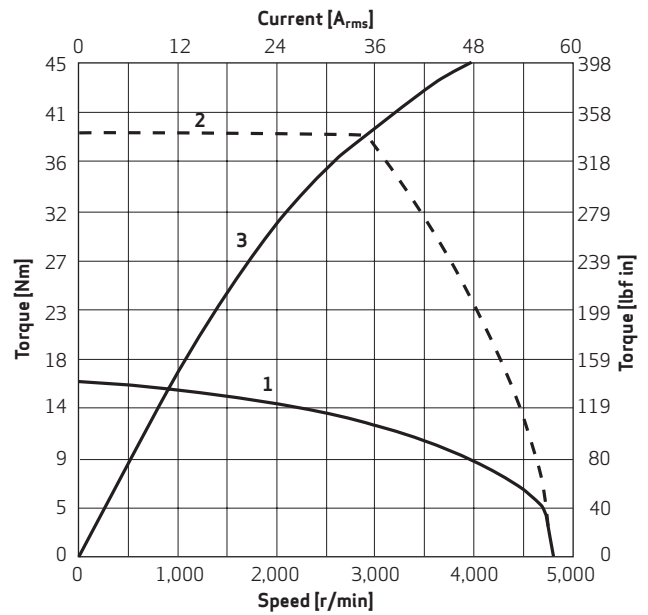

**G-5LM8 (L50)**

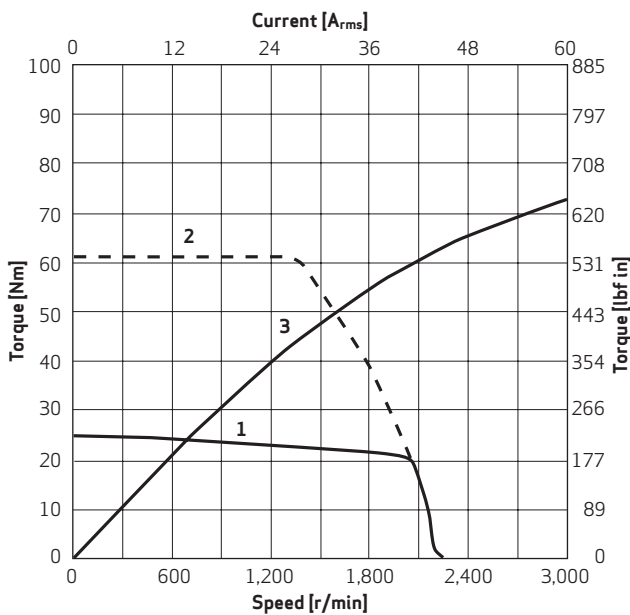

**G-5LV8 (L50)**

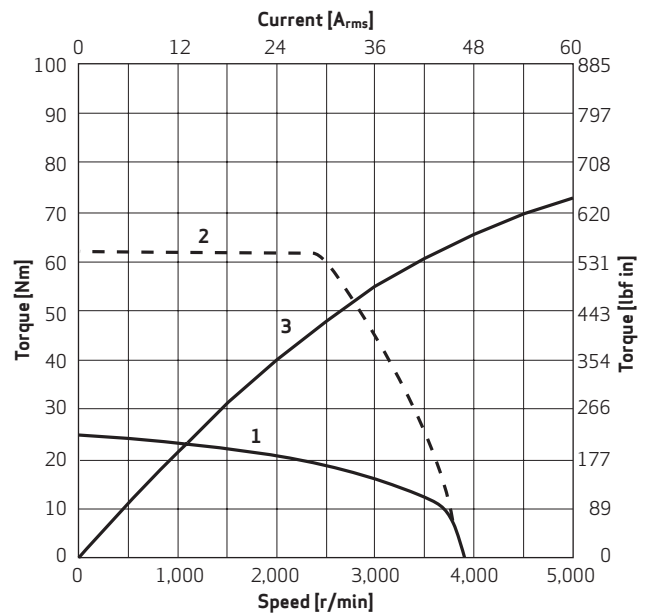

1 Continuous torque    2 Maximum torque    3 Torque constant  $k_T$

# SIZE 5

## Type G-5L, Dimensions

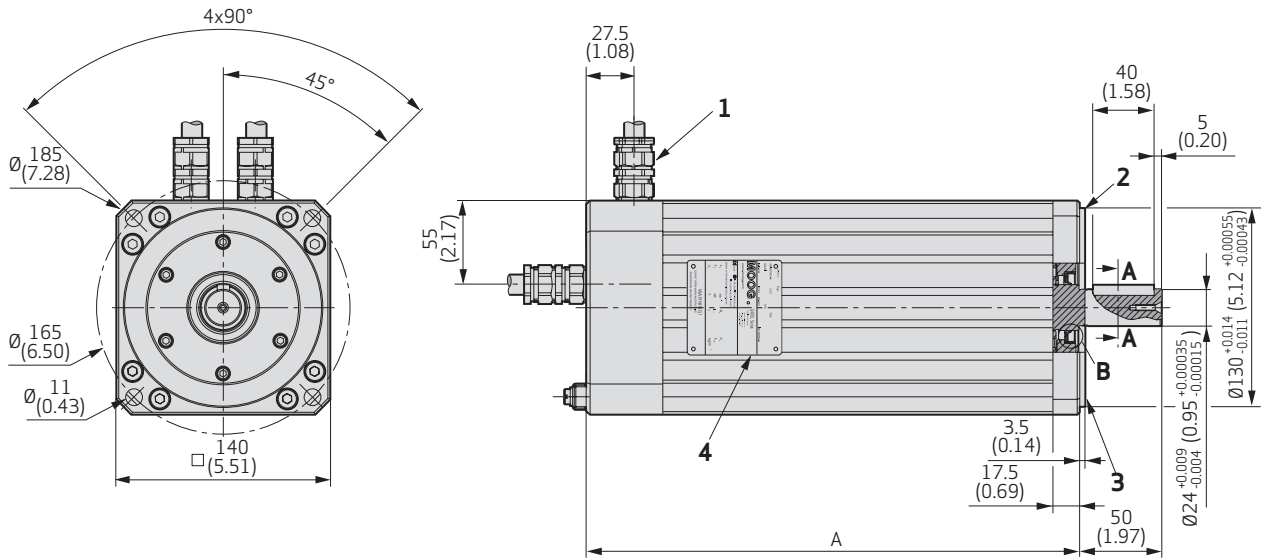

**SECTION A-A**

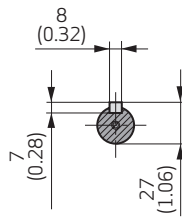

**Detail B**

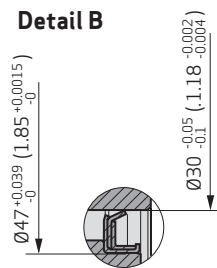

**Cable Gland**

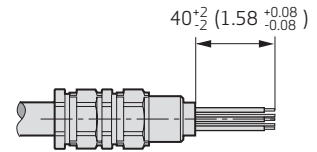

**Sectional view for connection cable**

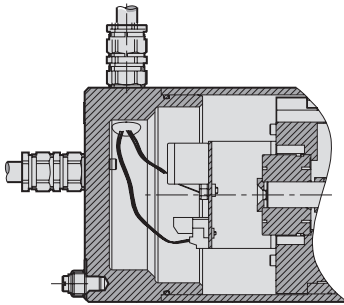

- 1 Alternative cable outlet
- 2 Tolerance of shaft extension run out and mounting flange DIN 42955
- 3 Flange IEC 34 DIN 42948
- 4 Name plate

Motor Length	Dimension "A"	Dimension "A"
[mm (in)]	- Resolver with brake - Encoder with brake	- Resolver without brake - Encoder without brake
L10	322.5 (12.70)	262.5 (10.33)
L20	347.5 (13.68)	287.5 (11.32)
L30	373 (14.69)	313 (12.32)
L50	424 (16.69)	364 (14.33)

**Note:**  
NEMA/IEC metric mounting

# WIRING DIAGRAM

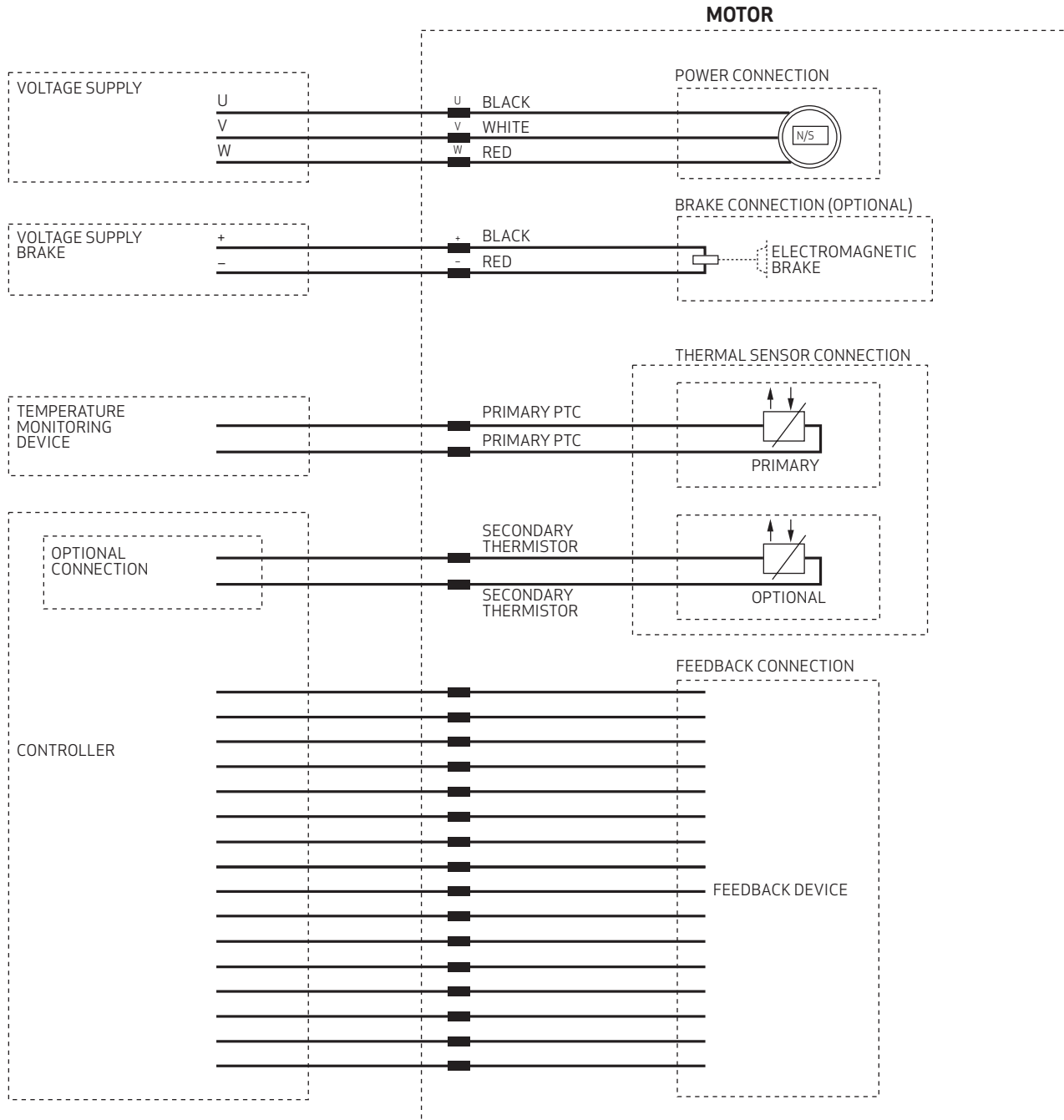

## BEARING LOAD DIAGRAMS

### Maximum Permissible Shaft Load

The maximum permissible radial load depends on desired service life.

The bearing load curves display servo motor configurations (motor speed: radial loads) that support an operational life of 20,000 hours (L10h).

For maximum axial loads values for individual servo motor models, see the table below. Consult Moog for extended service life requirements or alternate load conditions.

**Note:**

Load capacity referenced to middle of output shaft.

Type	Axial load during operation	Axial load during installation
G-3L	75 N	150 N
G-5L	200 N	400 N

### G-3L

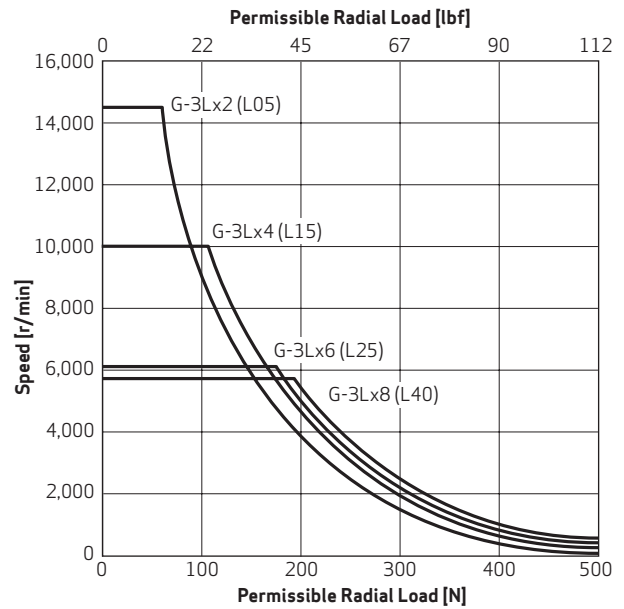

### G-5L

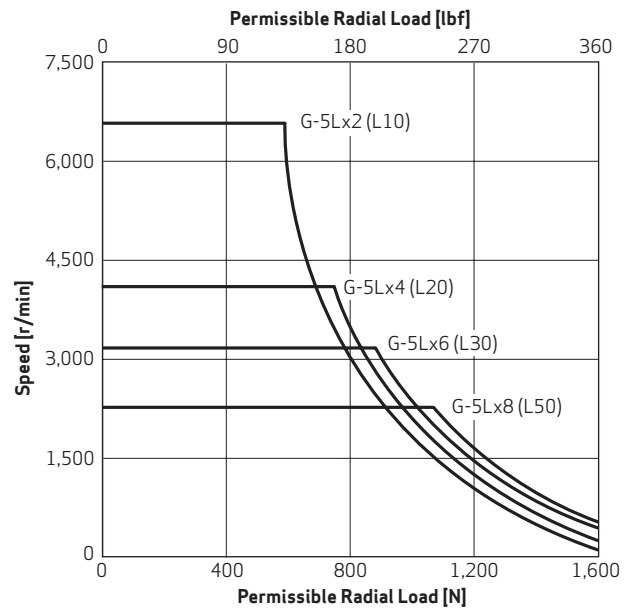

## APPLICATION NOTE

This application note aims to provide the user with some tools and guidelines for the correct motor sizing for a new application. When a fully optimized system is required, please contact your local Moog application engineers.

Its important to define the hazardous location before the selection of the motor. IEC 60079-11 defines the methodology for classifying hazardous location. The classification could be in terms of the following points.

- Zone of operation
- Type of gas present
- Type of dust present
- Temperature rating of the motor
- Type of connection required (cable gland with cable length required)
- Type of ingress protection required.

Based on the hazardous location classification, certification of motor is defined. The Moog ExD Servo Motor Series have been certified by UL for ATEX and IECEx certification wherein the certification code defines the application to be II C for gasses and III C for dust protection, with permissible maximum surface temperature range from 85 to 135 °C (185 to 275 °F) based on ignition temperature class.

In addition to the Hazardous location from safety point of view, all explosion proof motors are equipped with a primary set of thermistor which is always a PTC thermal sensor. This PTC thermal sensor must be connected to a temperature monitoring device which in turn should trip the motor when a motor cross the maximum allowable temperature. For selection of temperature monitoring device contact our local application engineer.

Once the hazardous location and the certification requirement of the motor have been defined, the sizing of the motor can be done.

A motor is selected to meet four characteristics:

1. RMS torque
2. Peak torque
3. Speed
4. Inertia ratio

Validation may be necessary to ensure the correct thermal and electric sizing of the motor. Contact our local application engineer for additional information and support.

## APPLICATION NOTE

### General Information

1. Motors designed to EN 60034 (VDE 0530)
2. Certified to ATEX and IECEx
3. Rotors balanced to Class G 6.3 per ISO 1940
4. Sealing to IP65
5. Operating ambient temperature refer to box car
6. Class F winding insulation
7. Motor flange dimensions per IEC 34, NEMA MG7, DIN 42948, ISO 286
7. Motor shaft dimensions per DIN 748
8. Motor shaft keyway per DIN 6885, IEC 72-1
9. Feedback Sensors
  - a) Resolver
  - b) Encoder
    - Incremental
    - Absolute single-turn
    - Absolute multi-turn
10. G-3L and G-5L servomotors are available in two versions:
  - G-xLM: designed for the use of 325 V<sub>DC</sub> link
  - G-xLV: designed for the use of 565 V<sub>DC</sub> link
11. Winding temperature sensors (standard version):
  - PTC as per temperature class and NTC
12. Sealed life-time lubricated bearing
13. Cable gland optional

### Notes

1. Continuous ratings based upon:
  - Operation in still air with ambient temperatures as indicated in the specification table.
  - Motor front flange attached to a steel mounting plate measuring 300 x 300 x 12 mm (11.81 x 11.81 x 0.47 in).
2. Peak ratings based on:
  - Duty cycle of 10 % (1 out of 10 seconds).
3.  $k_T$ -line show non-linearity between current and torque at high end.
4. Nominal speed and power values at maximum continuous output power with conditions per note 1
5. Resistance and inductance measurement based on "cold" values (i.e., measured at 25 °C (77 °F)).
6. Current ratings are Arms per phase.
7. Motor performance as measured with Moog drives at 325 V<sub>DC</sub> link for the G-xLM motor and 565 V<sub>DC</sub> link for G-xLV motor. For other drives and voltage levels, please talk to you Moog local application engineers.
8. Specification tolerances are ±10 %.
9. The maximum speed,  $n_{max}$ , is the maximum allowable operating speed. This speed is either limited by the voltage limiting Back E.M.F. characteristic or mechanically by centrifugal forces and/or bearing-stressing, whichever value is lower.

## ABOUT MOOG

Moog Inc. is a worldwide designer, manufacturer and integrator of precision control components and systems. Moog's Industrial Group designs and manufactures high performance motion control solutions combining electric, hydraulic, and hybrid technologies with expert consultative support in a range of applications including energy production and generation machinery, industrial production machinery and simulation and test equipment. We help performance-driven companies design and develop their next-generation machines. Moog's Industrial Group, with fiscal year 2010 sales of USD 540 million and over 40 locations worldwide, is part of Moog Inc. (NYSE:MOGA and MOG.B) which has sales of USD 2.1 billion.

Moog maintains facilities in 25 countries around the globe. This vast scope ensures that our engineers remain close to the needs of machine builders and provide flexible design solutions and technical expertise tailored to our customers' toughest challenges.

Moog experts work in close collaboration with machine builders and application engineers to design motion control systems for greater productivity, higher reliability, superior connectivity, less costly maintenance and more effective operations. Our regional presence, industry knowledge and design flexibility ensures Moog motion control solutions are tailored to their environment – from meeting operating regulations and performance standards, to taking machine performance to a higher level.

### Products

At the heart of every Moog solution is an array of products engineered for precision, high performance and reliability. For more than six decades, Moog products have been specified for critical machine applications.

Some are developed specifically for unique operating environments. Others are standard equipment on machines across many industries. All are continuously improved to take advantage of the latest technology breakthroughs and advancements.

Moog products include:

- Servo Valves and Proportional Valves
- Servo Motors and Servo Drives
- Servo Controllers and Software
- Radial Piston Pumps
- Actuators
- Integrated Hydraulic Manifold Systems and Cartridge Valves
- Slip Rings
- Motion Bases



Servo Drives



Servo Motors



Servo Valves

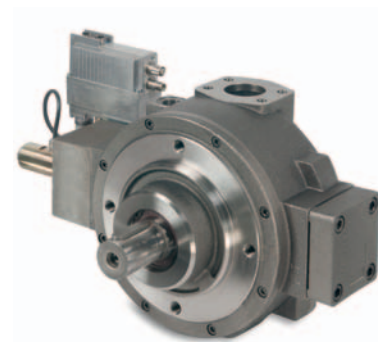

Radial Piston Pumps

## ABOUT MOOG

### Hydraulic solutions

Since Bill Moog invented the first commercially viable Servo Valve in 1951, Moog has set the standard for world-class hydraulic technology. Today, Moog products are used in a variety of applications - providing high power, enhanced productivity and ever better performance for some of the worlds most demanding applications.

### Electric solutions

Clean operation, low noise generation, less maintenance and reduced power consumption make Moog electric solutions ideal for applications worldwide. Moog is the ideal partner for applications where transitioning technologies requires special expertise.

### Hybrid solutions

By incorporating the advantages of existing hydraulic and electric technologies - including modular flexibility, increased efficiency and cleanliness - into innovative hybrid solutions, Moog offers new performance potential in specialized applications.

### Moog Global Support

Moog Global Support™ is our promise to offer world-class Repair and Maintenance Services delivered expertly by our trained technicians. With the reliability only available from a leading manufacturer with facilities around the world, Moog offers you service and expertise you can count on to keep your equipment operating as it should.

This promise offers many benefits to our customers including:

- Reduce your downtime by keeping critical machines running in peak performance
- Protect your investment by ensuring reliability, versatility and long-life of products
- Better plan your maintenance activities and make systematic upgrades
- Leverage our flexible programs to meet the unique service requirements of your facility

Look to Moog for global support including:

- Repair services using OEM parts are performed by trained technicians to the latest specifications
- Stock management of spare parts and products to prevent unplanned downtime



- Flexible programs, tailored to your needs such as upgrades, preventative maintenance and annual/multi-year contracts
- On-site services bring the expertise to you, providing quicker commissioning, set-up and diagnostics
- Access to reliable services that are guaranteed to offer consistent quality anywhere in the world

For more information on Moog Global Support™, visit [www.moog.com/industrial/service](http://www.moog.com/industrial/service).



## OPTIONS

### Flexible Design Options

Moog's ExD Series Servo Motors are available with a variety of standard and custom options to address the unique requirements of your application. Moog's motor design and application teams are continually introducing new options to address the changing needs of the market place. As a result, if you need something that's not presently listed, contact your local sales office.

#### Standard Options

##### Integral Holding Brake

Holding brakes are available for all standard ExD Series Servo Motors. The brake is a permanent magnet style that is designed to hold the axis in position even with power removed. This is especially useful in applications where the motor is on an axis controlling a weight-induced load (e.g., vertical axis on a gantry robot). Note, the brake is a holding brake and is not designed to stop dynamic loads. The servo drive is required to decelerate the axis and hold position before the brake is engaged.

The integral holding brake requires a regulated 24 V<sub>DC</sub> supply (see Accessories) for proper operation. Refer to motor technical data for brake current requirements.

Please note that the brake is a holding brake and is not designed to stop dynamic loads. The Servo Drive is required to decelerate the axis and hold position before the brake is engaged.

##### Shaft Options

Standard ExD Series Servo Motors are available with plain or slot and key metric shafts. For custom motor shafts such as spline or English dimension shafts, see Customizable Options.

#### Custom Options

##### Motor Windings

Moog's standard ExD Series Servo Motors are designed to address the needs of most dynamic motion control applications. However, Moog recognizes that OEMs have unique needs which cannot always be addressed by catalog products. This is why Moog offers custom motor windings. Custom motor windings may be used to optimize motor performance in applications with non-standard bus voltages or deliver customized performance characteristics for applications with unique speed or current requirements. However our custom winding will be adhered to only when it meet the Ex standard requirement.

##### Custom Shafts and Flanges

To support legacy products or meet unique application needs, Moog's modular ExD Series Servo Motor design is capable of supporting custom shafts (length, diameter or spline fittings) and custom flanges.



##### Custom Feedback Options

In addition to encoder adapter kits (see Standard Options), Moog can support requests for special feedback devices. Options presently offered include integral encoders (incremental or absolute). In addition to standard resolver and encoder options as detailed in the "Ordering Information", Moog can support requests where practical, for special feedback devices such as other resolver or encoders types.

##### Cable Gland with Cable

Customized cable with suitable cable gland as a part of custom option to meet the desired connection to the servo drive, temperature monitoring device and power supply.

#### Accessories

To speed-up your design cycle, Moog offers a variety of accessories which have been specified and tested for compatibility with our motors and drives. These accessories will also minimize assembly activities, allowing you to reduce production time.

- Recommended drives: See Moog's Servo Drive [catalog](#)
- To obtain pre-assembled motor cables, crimp tools, power supplies, please contact Moog's representative.

## ORDERING CODE

### Example

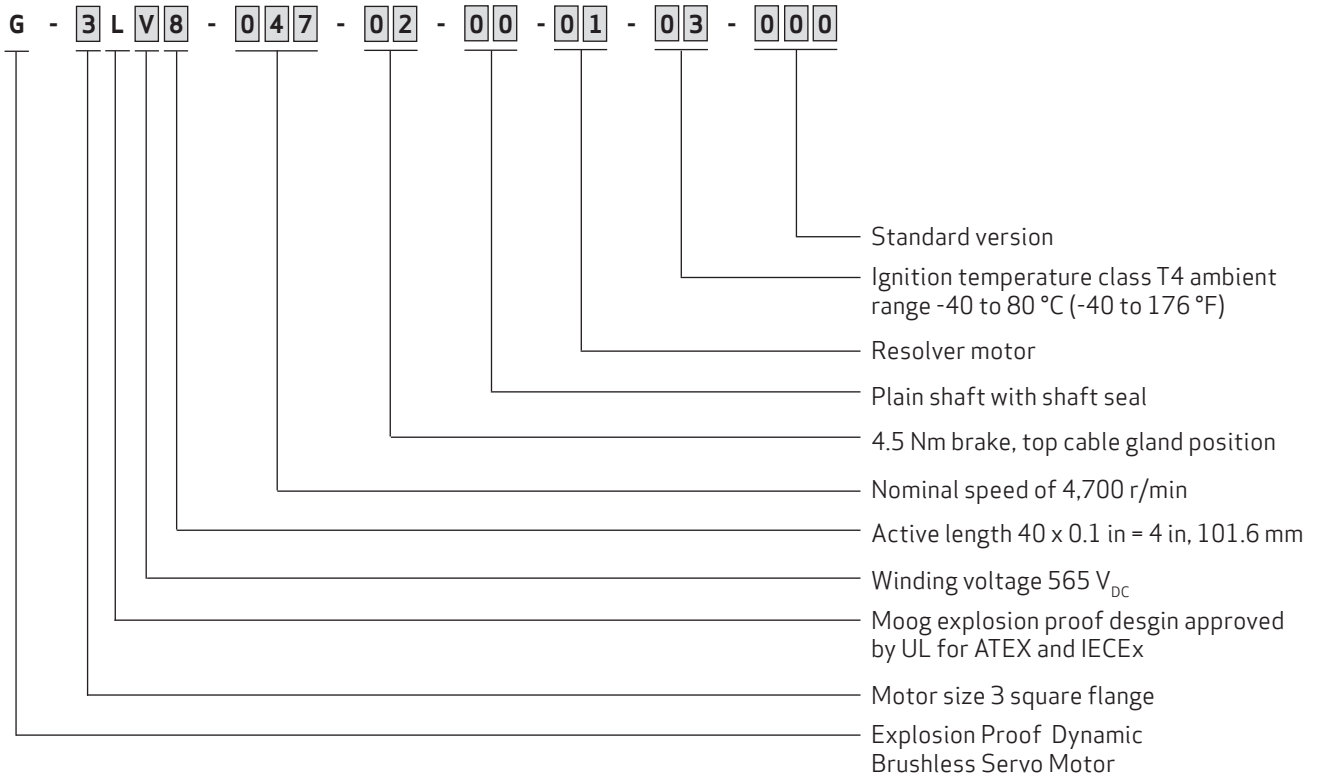

### Motor Nameplate

To order a motor, choose the various Type options by filling in the boxcar on the inside back page of the catalog.

Moog sales department will provide the corresponding Model number suitable for the order.

Both model number and box car (Model and Type respectively, as in picture) will be present on the motor nameplate.

# ORDERING CODE

G -  L   -    -   -   -   -    -

Motor size	
Square flange	
3	70 mm
5	140 mm

**Moog Ex Design approved by UL**

Winding voltage	
Voltage	
M	Low
V	High

**Thermal sensor:** First set of themistor is PTC only (No Option). Second set of themistor is NTC as standard. Option second set of themistor can be PTC or KTY.

Stack length		
Motor size		
	3	5
0	Special <sup>1)</sup>	
2	L05	L10
4	L15	L20
6	L25	L30
8	L40	L50

Active lenght in 0.1 inch  
<sup>1)</sup> Any non standard stack length b/w L05 to L40 for size 3 and b/w L10 to L50 for size 5.

Nominal speed	
xxx	r/100 min

Example: r/min = 3500/100 → 035

Mechanical options		
	Keyway	Shaft exit seal
00		
01		
99	Special	

Special version	
000	Standard version

Ignition temp class/ambient						
Motor size 3						
[°C (°F)]	-40 to +40 (-40 to +104)	-40 to +50 (-40 to +122)	-40 to +60 (-40 to +140)	-40 to +70 (-40 to +158)	-40 to +80 (-40 to +176)	
00	T4	T4	T4	T4	T4	
01	T5					
02	T6					
Motor size 3						
[°C (°F)]	-20 to +40 (-4 to +104)	-20 to +50 (-4 to +122)	-20 to +60 (-4 to +140)	-20 to +70 (-4 to +158)	-20 to +80 (-4 to +176)	
03	T4	T4	T4	T4	T4	
04	T5					
05	T6					
Motor size 5						
[°C (°F)]	-40 to +40 (-40 to +104)	-40 to +50 (-40 to +122)	-40 to +60 (-40 to +140)	-40 to +70 (-40 to +158)	-40 to +80 (-40 to +176)	
00	T4	T4	T4	T4	T4	
01	T5					
02	T6					
99	Special					

Electrical options				
	Brake options		Cable gland position <sup>1)</sup>	
	1	2	Top	Back
00				
01				
02				
03				
04				
05				
99	Special for brake only (Cable gland position and size can not be changed)			

<sup>1)</sup> Standard Motor delivered without cable gland and cable.

Feedback option				
	Motor size		Resolver/encoder type	
	3	5		
00	not allowed			
01	2 poles resolver			
02	CKS36	CNS50	Incremental	Stegmann
03	SKS36	SRS50	Abs single turn	
04	SKM36	SRM50	Abs multi turn	Heidenhain
05	ERN1185	ERN1387	Incremental	
06		ECN1313	Abs single turn	
07		EQN1325	Abs multi turn	
99	Special			

Brake options <sup>1)</sup>			
	Motor size	3	5
1	Low-T	2 Nm	18 Nm
2	High-T	4.5 Nm	30 Nm

<sup>1)</sup> Size 3 encoder motors are always without brake

# TAKE A CLOSER LOOK.

Moog designs a range of motion control products that complement the performance of those featured in this catalog. Visit our website for more information and contact the Moog facility nearest you.

Argentina  
+54 11 4326 5916  
info.argentina@moog.com

India  
+91 80 4057 6605  
info.india@moog.com

Singapore  
+65 677 36238  
info.singapore@moog.com

Australia  
+61 3 9561 6044  
info.australia@moog.com

Ireland  
+353 21 451 9000  
info.ireland@moog.com

South Africa  
+27 12 653 6768  
info.southafrica@moog.com

Brazil  
+55 11 3572 0400  
info.brazil@moog.com

Italy  
+39 0332 421 111  
info.italy@moog.com

Spain  
+34 902 133 240  
info.spain@moog.com

Canada  
+1 716 652 2000  
info.canada@moog.com

Japan  
+81 46 355 3767  
info.japan@moog.com

Sweden  
+46 31 680 060  
info.sweden@moog.com

China  
+86 21 2893 1600  
info.china@moog.com

Korea  
+82 31 764 6711  
info.korea@moog.com

Switzerland  
+41 71 394 5010  
info.switzerland@moog.com

Finland  
+358 10 422 1840  
info.finland@moog.com

Luxembourg  
+352 40 46 401  
info.luxembourg@moog.com

United Kingdom  
+44 168 429 6600  
info.uk@moog.com

France  
+33 1 4560 7000  
info.france@moog.com

Netherlands  
+31 252 462 000  
info.thenetherlands@moog.com

USA  
+1 716 652 2000  
info.usa@moog.com

Germany  
+49 7031 622 0  
info.germany@moog.com

Norway  
+47 6494 1948  
info.norway@moog.com

Hong Kong  
+852 2 635 3200  
info.hongkong@moog.com

Russia  
+7 8 31 713 1811  
info.russia@moog.com

## [www.moog.com/industrial](http://www.moog.com/industrial)

Moog is a registered trademark of Moog Inc. and its subsidiaries. All trademarks as indicated herein are the property of Moog Inc. and its subsidiaries.

©2011 Moog Inc. All rights reserved. All changes are reserved.

ExD Series Brushless Servo Motors  
Gut/PDF/Rev. A, October 2011, Id. CDL32776-en