

Application Notes

1 Scope

These Application Notes are a guide to applying the G123-820 Setpoint & Ramp. They cover the following process:

- Determine the structure of your application.
- Select the G123-820 for your application. Refer also to data sheet G123-820.
- Use these Application Notes to determine your system configuration.
- Draw your wiring diagram.
- Install and commission your system.

Aspects such as hydraulic design, actuator selection and performance estimation are not covered by these Application Notes. Moog Application Engineers can provide more detailed assistance, if required.

2 Description

The G123-820 is a command signal generator that produces a sequence of ramped commands suitable for use as an input signal to a proportional valve for open loop control of a cylinder or motor. User supplied logic inputs to the G123-820 select the four front panel set points, output polarity and ramp off.

The four front panel **set point** potentiometers and an externally connected analog input signal are summed, passed through a polarity selector circuit and then a ramp circuit before being presented as an output signal to command the proportional valve. The ability to select any of the four set points and the feature of setting the **ramp** time, depending on output polarity and direction of change of the ramp, make the G123-820 particularly versatile. An output deadband, that forces the output to zero when the ramp output is within $\pm 4\%$ of zero, is very useful for open loop applications. Front panel test points enable measurement of the four internal **set points** and the four **ramp** rates.

The ability to measure the potentiometer settings "off-line", on the front panel, enables system set-up without the need to continuously cycle the process and eliminates the requirement for an additional test box. Once the values for a particular process are known, they can be used for all subsequent systems that are required to be set up.

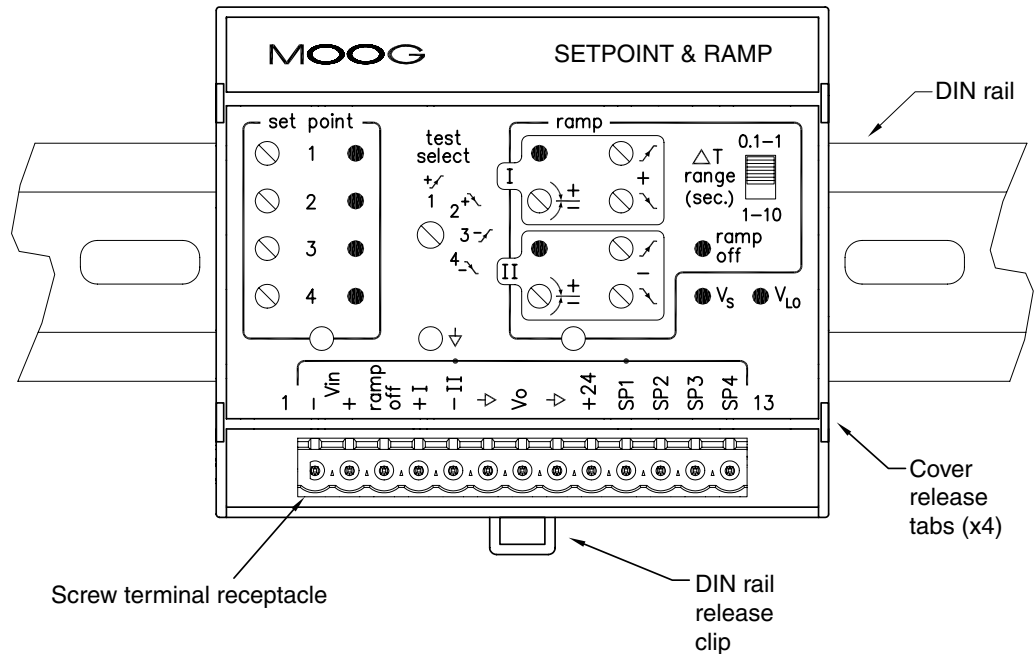

3 Installation

3.1 Placement

A horizontal DIN rail, mounted on the vertical rear surface of an industrial steel enclosure, is the intended method of mounting. The rail release clip of the G123-820 should face down, so the front panel and terminal identifications are readable.

An important consideration for the placement of the module is electro magnetic interference (EMI) from other equipment in the enclosure. For instance, VF and AC servo drives can produce high levels of EMI. Always check the EMC compliance of other equipment before placing the G123-820 close by.

3.2 Cooling

It is important to ensure that equipment located below does not produce hot exhaust air that heats up the G123-820.

3.3 Wiring

The use of crimp "boot lace ferrules" is recommended for the screw terminals. Allow sufficient wire length so the 13 position screw terminal connector can be withdrawn from its mating connector on the G123-820. It is difficult to remove this connector by hand. There are two slots in the case, below the connector, that accept a flat blade screw driver, that when twisted in the slot, will release the connector.

Terminal identification is on the block diagram on page 5.

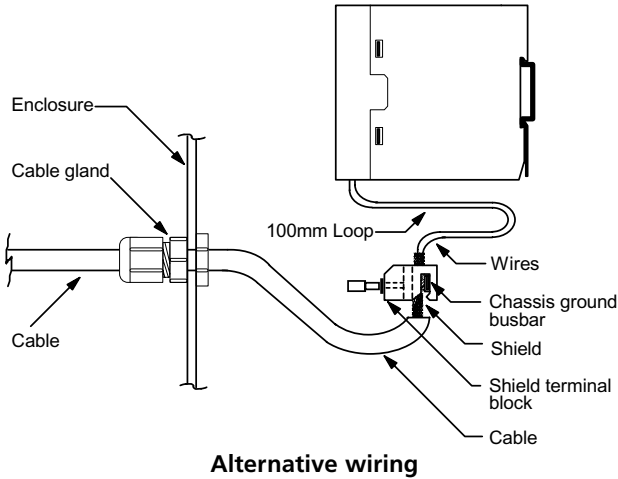
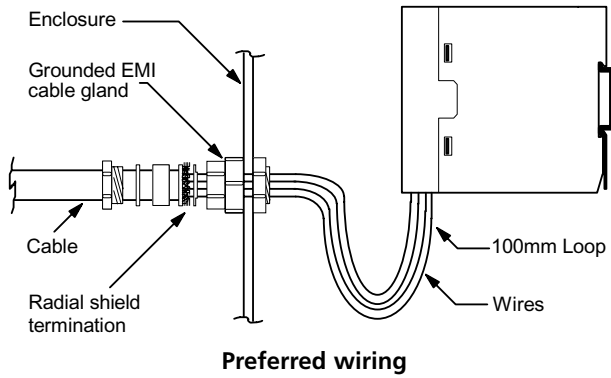

3.4 EMC

The G123-820 emits radiation well below the level called for in its CE mark test. Therefore, no special precautions are required for suppression of emissions. However, immunity from external interfering radiation is dependent on careful wiring techniques. The accepted method is to use shielded cables for all connections and to radially terminate the cable shields, in an appropriate grounded cable gland, at the point of entry into the industrial steel enclosure. If this is not possible, the use of a busbar mounting "shield terminal block", such as Phoenix SK8, is recommended. Exposed wires should be kept to a minimum length. Connect the shields at both ends of the cable to chassis ground.

4 Power supply

24V nominal, 22 to 28V

125mA, with maximum number of LEDs on.

If an unregulated supply is used the bottom of the ripple waveform is not to fall below 22V.

It is recommended that the M205, 250mA T (slow blow) fuse, supplied with the unit, be placed in series with the +24V input to protect the electronic circuit. There is a spare fuse in the cover of the fuse holder. Replacement fuses should be compliant with IEC 127-2 sheet 3.

5 Detailed description

Refer to the block-wiring diagram on page 5.

5.1 Set points

The four front panel set points and the analog input set point are summed to produce a single set point signal that is then processed by the polarity selector and ramp circuit. The four front panel set points are connected to the summing point only when selected by their corresponding select logic input. The maximum output is 10V, so if the sum of all selected set points and the analog set point is greater than 10V, the output will be limited to 10V. The front panel **set point** pots have an output of 0 to +10V. Turning a pot clockwise increases the set point. The analog input has a range of $\pm 10V$.

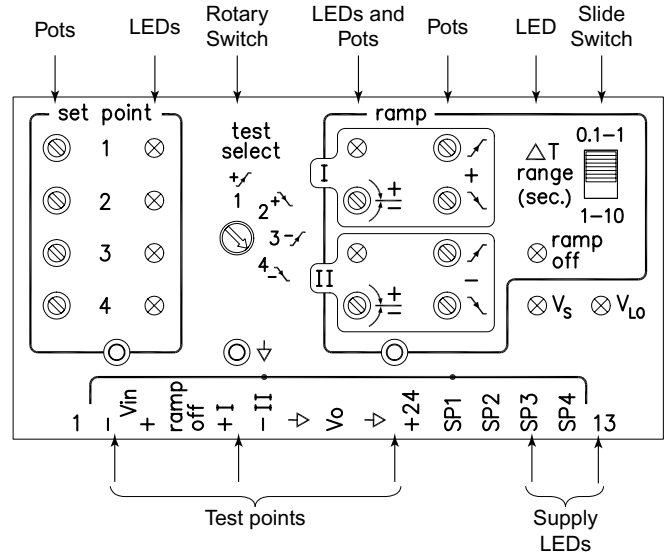

5.2 Output polarity

The output polarity is selected by the mode I and II logic screw terminal inputs. For an analog input V_a and set point input V_{sp} , as shown in the graphs to the right, the three different output graphs are shown below.

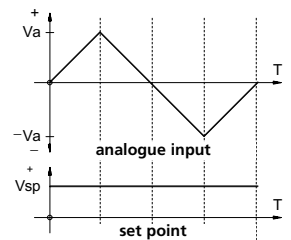

- Mode I: The positive **set point** pot signals are passed through to the ramp unchanged. Only positive signals from the analog input are passed through to the ramp. Thus the output range is 0 to +10V.

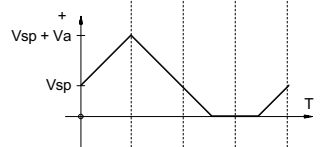

- Mode II: The positive **set point** pot signals are inverted, ie. A pot setting of +5.5V produces -5.5V on the input to the ramp circuit. The analog input signal is also inverted so the positive input produces a corresponding negative output. A negative analog input signal is blocked.

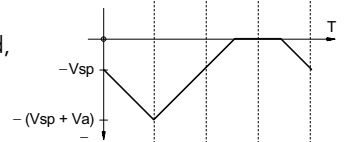

- Mode I and II together: The positive **set point** pot signals and the analog input are summed and ramped unaltered. Thus the output swings the full +10V to -10V. eg. If **set point 1** is the only selected set point and it is set to +5.0V and the analog input is -7.0V, the output will be -2.0V.

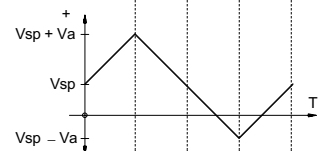

When Modes I and II are selected together the **mode select** LEDs illuminate only when the output signal is the corresponding polarity. When the output signal is within the deadband window of $\pm 0.4V$ both **mode select** LEDs will be off.

5.3 Ramps

The four **ramp** times, **I ↗** (positive up), **I ↘** (positive down), **II ↗** (negative up) and **II ↘** (negative down) are automatically selected by an internal circuit that senses the output polarity and the direction of the ramp, either increasing (up), or decreasing (down). Each has a ten to one range. The **ΔT range** switch selects either a **0.1–1sec** or **1–10sec** range. The time is specified as the time taken for the ramp to change by 10V. Turning the pots clockwise increases the time.

5.4 Zero

The mode I and II **zero** pots are present on the output when the corresponding mode LED is illuminated.

The I **zero** pot has an adjustment range of 0 to +1.2V.

The II **zero** pot has an adjustment range of 0 to -1.2V.

Turning the pots clockwise increases the zero value.

5.5 Output deadband

- Mode I only or Mode II only: When the output of the ramp circuit is inside a window of $\pm 0.4V$, the ramp output is not present on the G123-820 output. Only the selected **zero** pot is present on the output. When the ramp output exceeds $\pm 0.4V$, it is present on the G123-820 output. At the start of a cycle, assuming the internal ramp output starts at 0V, the G123-820 output will jump from the zero setting by 0.4V when the internal ramp output exceeds 0.4V.
- Mode I and II together: Both the zero and ramp output are not present on the G123-820 output when the ramp output is inside the $\pm 0.4V$ window. Thus the output is 0V until the internal ramp output exceeds 0.4V. At this point the output jumps to 0.4V plus the value of the appropriate zero pot setting.

5.6 Test points

The two test points, **set point** and **ramp**, enable the selected pot setting to be measured with reference to the **0V** (\downarrow) test point. The four position **test select** switch selects pairs of set points and ramps. e.g., position **1+ ↗** selects:

- **set point one** on the **set point** test point, at the bottom of the set point front panel outline and
- **positive ramp up** rate on the **ramp** test point at the bottom of the ramp front panel outline.

Note: there is no logical connection between the signals in each pair. They are arranged this way to simplify the internal electronics.

The **set point** test point is scaled to have the same value as the set point.

The **ramp** test point scaling is shown in the following graph.

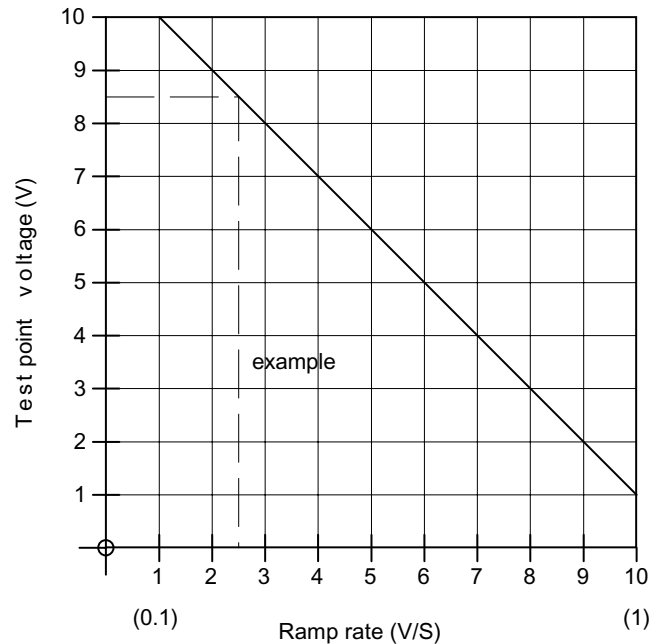

Ramp test point scaling

To determine the test point voltage for a particular ramp, calculate the ramp rate in volts per second and then determine the **ramp** test point voltage from the graph.

Example:

If a 5V ramp is required to have a time of 2 seconds, the ramp rate is 2.5V/S. From the graph determine that this requires a **ramp** test point voltage of 8.5V.

5.7 Ramp off

This function is selected by connecting +24 to the ramp off screw terminal. When selected, there is no ramping of output signals. Changes in set point result in an immediate change in the output signal.

6 Application example

6.1 Definition

A typical application is to move a load forward with a hydraulic cylinder, then quickly retract the cylinder without the load. The eight phases of this motion profile are:

1. Initial acceleration extending.
2. Constant velocity extending.
3. De-accelerate to a creep speed as final position is near.
4. Creep to final extended position.
5. Acceleration retracting.
6. Constant high velocity retracting.
7. De-accelerate to a creep speed as final retracted position is near.
8. Creep to final retracted position.

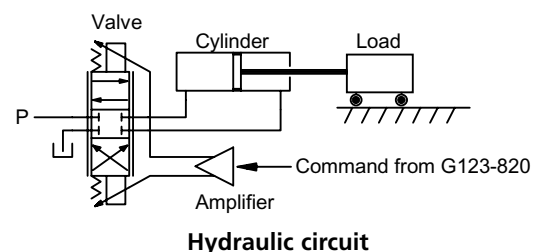

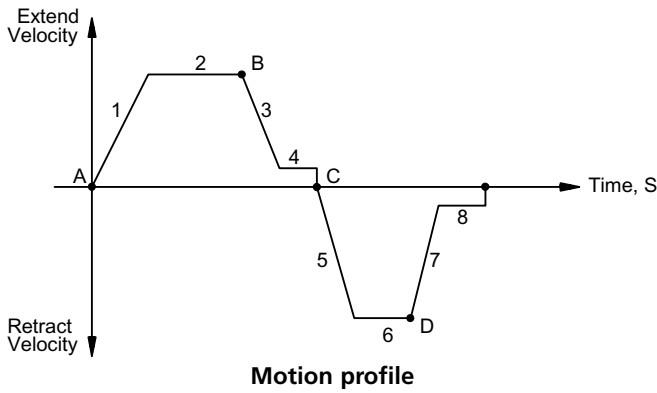

To implement this example, limit switches are needed to detect the following:

- A. Retract position
- B. Near final position
- C. Final position
- D. Near retract position

The four limit switches will select the appropriate setpoints for the profile:

- LS A selects extend velocity 2.
- LS B selects extend creep velocity 4.
- LS C selects retract velocity 6.
- LS D selects retract creep velocity 8.

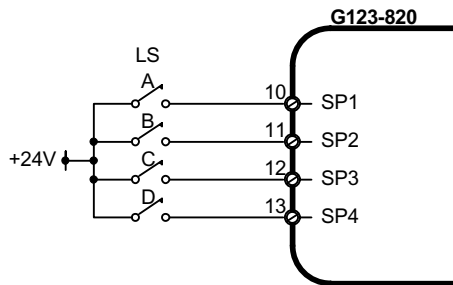

Limit switch set point selection

For this example the required performance is

- Stroke –1000mm
- Extend time –10S
- Retract time –6S
- Creep velocities –10mm/S

Assume 10V full scale valve command produces 400mm/S cylinder velocity.

- Allow: 2S to accelerate
- 5S at constant velocity
- 2S to de-accelerate
- 1S at creep velocity

6.2 Set points

Examining the extend profile:

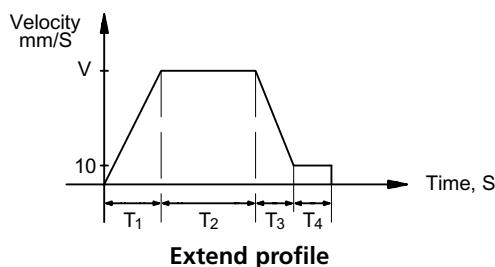

$$\text{Final position, } x = \frac{T_1V}{2} + T_2V + \frac{T_3V}{2} + 10T_4$$

For this example $x = 1000$, $T_1 = 2S$, $T_2 = 5S$, $T_3 = 2S$ and $T_4 = 1S$

$$1000 = \frac{2V}{2} + 5V + \frac{2V}{2} + 10$$

$V = 140 \text{ mm/S}$

Set point 1 is 140 mm/S.

$$\text{Set point 1} = \frac{140}{400} \times 10V = 3.5V$$

Set point 2 is 10 mm/S

$$\text{Set point 2} = \frac{10}{400} \times 10V = 0.25V.$$

However, the minimum output is 0.4V. Therefore set point 2 should be 0.5V, which corresponds to a creep velocity of 20 mm/S.

Calculate set point 3 in the same way as SP1 was calculated.

Velocity is 248mm/S

Therefore **set point 3** = 6.2V

Set point 4 is 10mm/S

Therefore **set point 4** = 0.5V (20 mm/S)

6.3 Ramps

The first ramp, 1, increments 3.5V in 2S. This is a ramp rate of 1.75V/S. From the graph in 5.6 determine that this requires a ramp test point setting of 9.25V.

Set **I / ramp** to 9.25V.

The second ramp, 3, has the same decrement as the first.

So, set **I \ ramp** to 9.25V.

The third ramp, 5, decrements 6.2V in 1S. This is a ramp rate of 6.2V/S. From the graph in 5.6 determine that this requires a ramp test point voltage setting of 4.8V.

Set **II \ ramp** to 4.8V.

Set **II / ramp** to 4.8V also.

6.4 Polarity

As the cylinder extends, mode I selection is required so the output command to the proportional valve is positive. As it retracts, mode II selection is required so the output is negative. Relay or PLC logic is required to select the appropriate mode, based on the sequencing of the limit switches. The circuit below shows a typical relay arrangement.

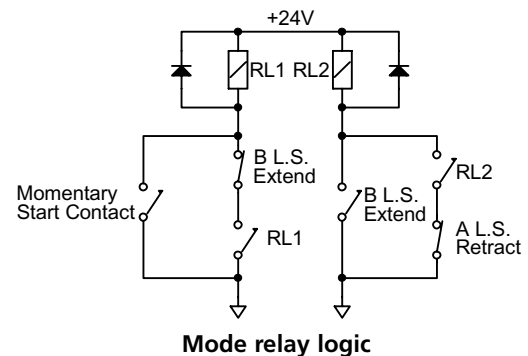

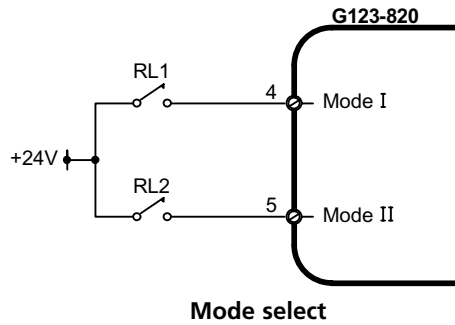

6.5 Timing diagram

The complete logic and analogue output timing diagram for this application example is shown below:

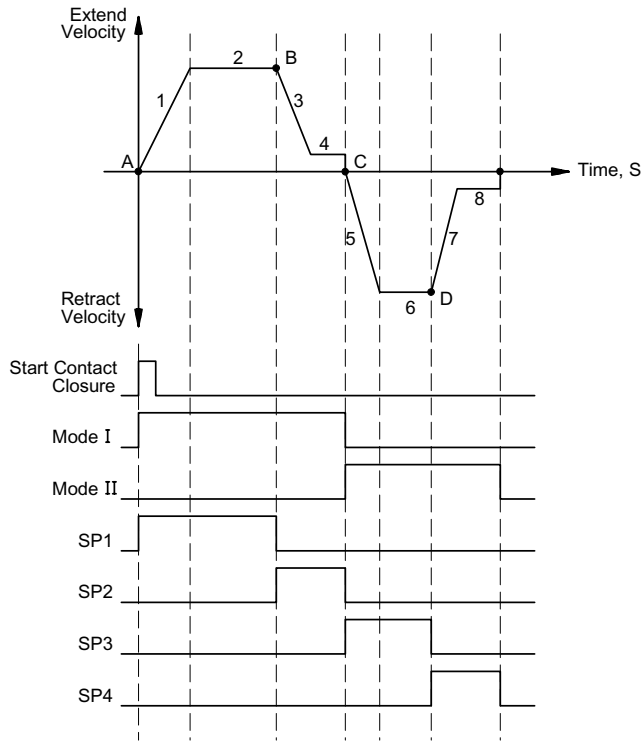

Ramp polarity and direction are automatically selected by a G123-820 internal circuit. Thus, no provision need be made for these.

6.6 Commissioning

When commissioning the system, a three step sequence needs to be followed:

- Optimise the creep speed so the stop meets requirements.
- Adjust the extend and retract speeds, 2 and 6, so the required times are achieved.
- Adjust the ramp times 1, 3, 5 and 7 for stable operation.

7 Specifications

Analog input:	Differential, 0 to $\pm 10V$ 100kOhm input resistance Common mode, $\pm 15V$ max.
Logic inputs:	On at 10V Off at 5V Max. 28V 5.1mA @ 24V
Analog output:	0 to $\pm 10V$ @ $\pm 10mA$ max. Short circuit and over voltage protected
Output deadband:	$\pm 4\%$ of full scale
Output polarity:	0 to +10V, mode I 0 to -10V, mode II 0 to $\pm 10V$, mode I and II together
Ramp times for 10V change:	0.1 to 1S, 1 to 10S
Front panel test points:	Selected set point, 0 to +10V Selected ramp, 0.1V/S or 1V/S 0V reference
Front panel switches:	Test point select ΔT ramp time range select, 0.1 to 1S and 1 to 10S
Front panel indicators:	Set points 1 to 4 select – amber I mode select, positive output – amber II mode select, negative output – amber Ramp off select – amber Vs, internal supply – green VLo, +24V supply below +17V – red
Front panel trim pots:	Set points 1 to 4 Ramp I ↗ Ramp I ↘ Ramp II ↗ Ramp II ↘ Zero I Zero II
Supply:	24V nominal, 22 to 28V 125mA @ 24V, max. no. of front panel LEDs on
Recommended supply protection:	M205, 250mA T (slow blow) fuse compliant with IEC 127-2 sheet 3
Mounting:	DIN rail to EN50002 Housing IP40 Terminal block IP20
Temperature:	0 to +40°C
Dimensions:	90W x 75D x 107.5H
Weight:	257gm
CE mark:	EN61000-6-3 emission EN61000-6-2 immunity
C tick:	EN61000-6-3 emission

8 Block-wiring diagram

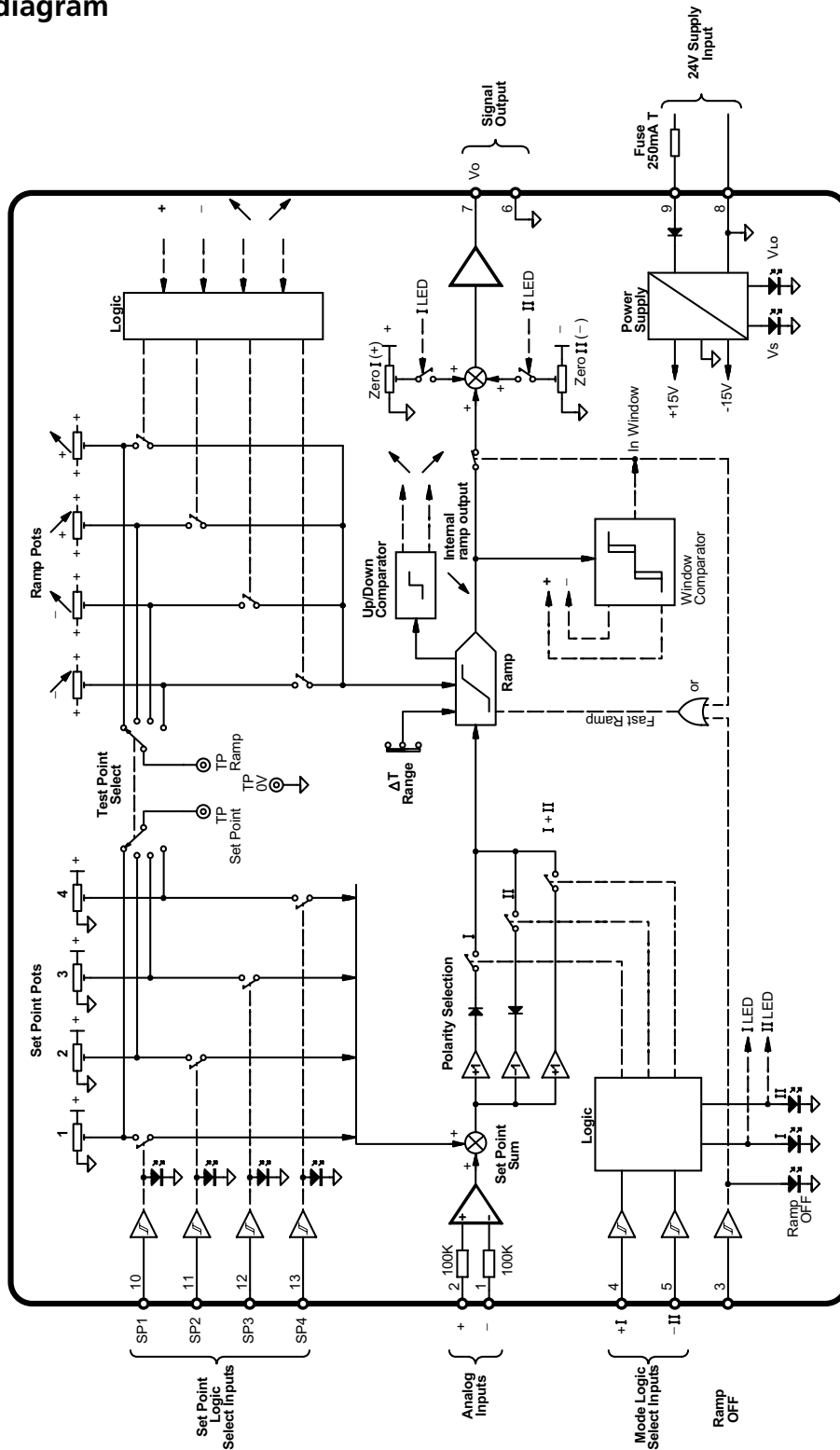

Internet Data

For a detailed Data Sheet and the latest version of these Application Notes, please refer to the Moog website www.moog.com/dinmodules

MOOG

Industrial Controls Division. Moog Inc., East Aurora, NY 14052-0018. Telephone: 716/652-3000. Fax: 716/655-1803. Toll Free 1-800-272-MOOG.

Moog GmbH. Germany. Telephone: 07031-622-0. Fax: 07031-622-100.

Moog Sarl. France. Telephone: 01 45 60 70 00. Fax: 01 45 60 70 01.

Moog Australia Pty. Ltd. Telephone: 03 9561 6044. Fax: 03 9562 0246.

Moog pursues a policy of continuous development and reserves the right to alter designs and specifications without prior notice. Information contained herein is for guidance only and does not form part of a contract.

Australia: Melbourne, Sydney, Brisbane ■ Austria: Vienna ■ Brazil: São Paulo ■ Denmark: Birkerød ■ England: Tewkesbury ■ Finland: Espoo ■ France: Rungis ■ Germany: Böblingen, Dusseldorf ■ Hong Kong: Shatin ■ India: Bangalore
Ireland: Ringaskiddy ■ Italy: Malnate (VA) ■ Japan: Hiratsuka ■ Korea: Kwangju-Kun ■ Philippines: Baguio City ■ Singapore: Singapore ■ Sweden: Askim ■ USA: East Aurora (NY)