

Application Notes

1 Scope

These Application Notes are a guide to applying the G122-829-003 P-I Servoamplifier. These Application Notes can be used to:

- Determine the closed loop structure for your application.
- Select the G122-829-003 for your application. Refer also to data sheet G122-829.
- Use these Application Notes to determine your system configuration.
- Draw your wiring diagram.
- Install and commission your system.

Aspects, such as hydraulic design, actuator selection, feedback transducer selection, performance estimation, etc. are not covered by these Application Notes. The G122-202 Application Notes (part no C31015) cover some of these aspects. Moog Application Engineers can provide more detailed assistance, if required.

2 Description

The G122-829-003 is a general purpose, user configurable, P-I servoamplifier. Selector switches inside the amplifier enable either proportional control, integral control, or both to be selected. Many aspects of the amplifier's characteristics can be adjusted with front panel pots or selected with internal switches. This enables one amplifier to be used in many different applications. The output amplifier is fixed at 4-20mA. Refer also to data sheet G122-829.

3 Installation

3.1 Placement

A horizontal DIN rail, mounted on the vertical rear surface of an industrial steel enclosure, is the intended method of mounting. The rail release clip of the G122-829-003 should face down, so the front panel and terminal identifications are readable and so the internal electronics receive a cooling airflow.

An important consideration for the placement of the module is electro magnetic interference (EMI) from other equipment in the enclosure. For instance, VF and AC servo drives can produce high levels of EMI. Always check the EMC compliance of other equipment before placing the G122-829-003 close by.

3.2 Cooling

Vents in the top and bottom sides of the G122-829-003 case provide cooling for the electronics inside. These vents should be left clear. It is important to ensure that equipment below does not produce hot exhaust air that heats up the G122-829.

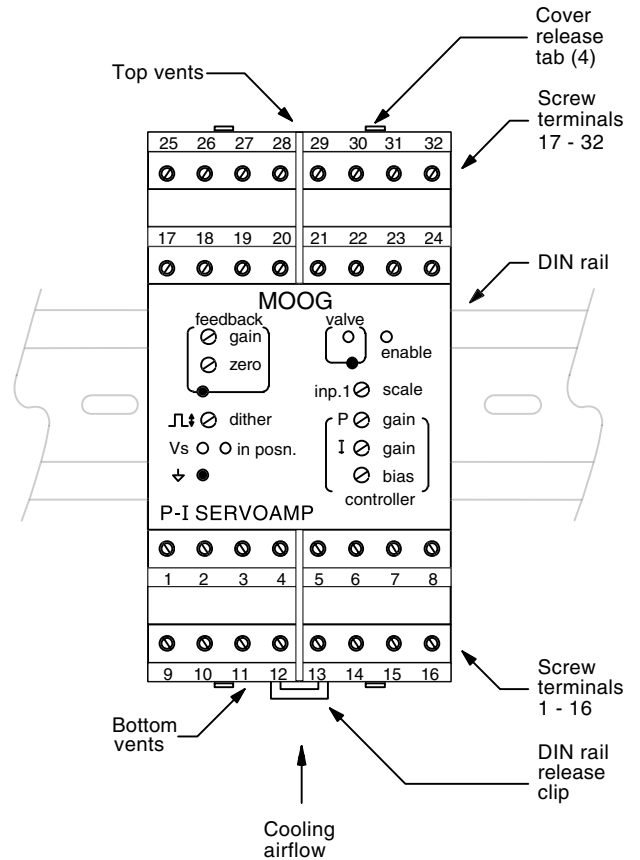

3.3 Wiring

The use of crimp “boot lace ferrules” is recommended for the screw terminals. Allow sufficient cable length so the circuit card can be withdrawn from its case with the wires still connected. This enables switch changes on the circuit card to be made while the card is still connected and operating. An extra 100mm, for cables going outside the enclosure, as well as wires connecting to adjacent DIN rail units, is adequate.

The screw terminals will accommodate wire sizes from 0.2mm² to 2.5mm² (24AWG to 12AWG). One Amp rated, 0.2mm² should be adequate for all applications.

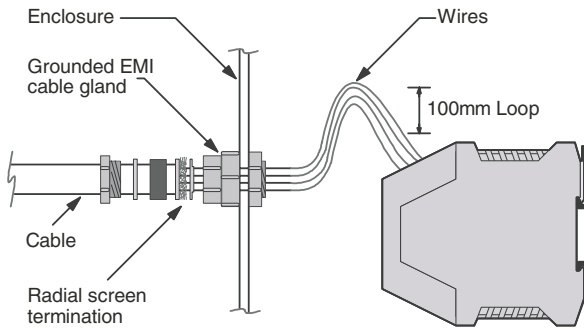

Preferred Wiring

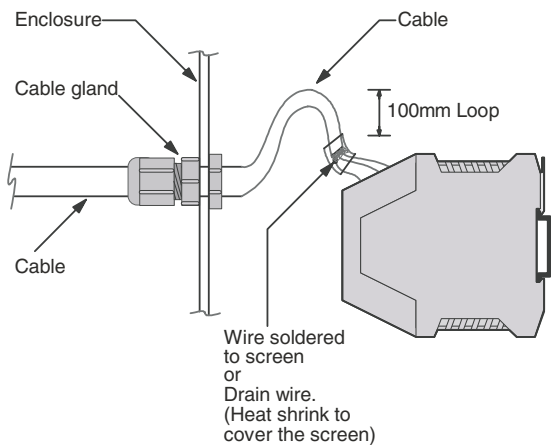

Alternative Wiring

3.4 EMC

The G122-829-003 emits radiation well below the level called for in its CE mark test. Therefore, no special precautions are required for suppression of emissions. However, immunity from external interfering radiation is dependent on careful wiring techniques. The accepted method is to use screened cables for all connections and to radially terminate the cable screens, in an appropriate grounded cable gland, at the point of entry into the industrial steel enclosure. If this is not possible, chassis ground screw terminals are provided on the G122-829-003. Exposed wires should be kept to a minimum length. Connect the screens at both ends of the cable to chassis ground.

4 Power supply

24V DC nominal, 22 to 28V
75mA @ 24V without a load, 200mA @ 100mA load.

If an unregulated supply is used the bottom of the ripple waveform is not to fall below 22V.

It is recommended that an M205, 250mA T (slow blow) fuse, compliant with IEC127-2 sheet 3, be placed in series with the +24V input to protect the electronic circuit.

5 Set-up adjustments

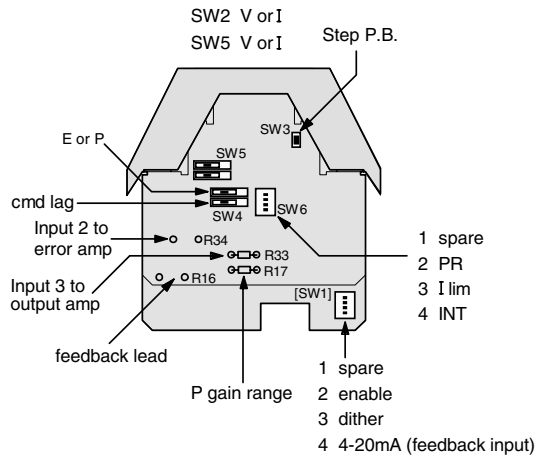

To access the circuit card switches, the circuit card must be withdrawn from the case. See paragraph 17.

SW1 + 6 switch positions

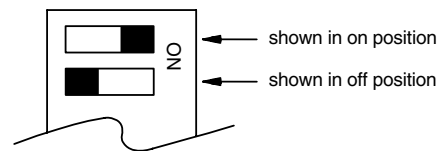

Trim pots are all 15 turns.

Plug-in resistors are all “quarter watt” 1% metal film. Two suitable types are Beyschlag MBB0207 and Roderstein MK20207.

The amplifier is shipped in the following default state.

- top board switches

SW3	STEP	not applicable
SW4-1	P-E	E
SW4-2	CMD LAG	off
SW5	IN 2	V
SW6	1 spare	off
	2 PR	on
	3 I Lim	off
	4 INT	off
- bottom board switch, shown as []

[SW1]	1 spare	off
	2 ENABLE	on
	3 DITHER	off
	4 4-20mA	on

■ R17: 100k (P gain range 1 to 20)

■ R34: 100k (input 2 to error amp)

■ R33: not fitted (input 3 to output amp)

■ R16: not fitted (feedback derivative)

- Feedback gain and zero pots: configured for 4-20mA input
- Dither level pot: fully counter clockwise (FCCW)
- Scale pot: FCCW
- P gain pot: FCCW
- I gain pot: FCCW
- Bias pot: 0V

Caution

If you intend to use the feedback amplifier adjusted for 4-20mA, don't change the feedback gain or zero.

- They are already adjusted for 4-20mA
- To re-adjust for 4-20mA takes a little time, needs test equipment and is tedious to do in the field.

6 Input configuration

Inputs 1, 2 and feedback go to the error amplifier and can be used for feedback or command. Care needs to be taken in selecting signal polarity to achieve negative feedback for the overall closed loop. Since the input error amplifier sums the signals, the transducer feedback signal needs to be the opposite polarity of the command. This can be achieved in two ways:

- Arrange for an opposite polarity feedback transducer signal and connect it to input 1, input 2 or the positive feedback amplifier input.
- If the feedback transducer signal is the same polarity as the command, you only have one option: Connect it to the negative input of the feedback amplifier.

6.1 Feedback input

An input to the error amplifier: The feedback amplifier is the best choice for the feedback signal, for six reasons:

- It leaves input 1 available for command. See 6.2 below.
- It has inverting (negative) and non-inverting (positive) inputs.
- It has zero and gain adjustment pots. This enables a signal that does not go to zero volts and has less span than the command, to be scaled up to the command. While this is not essential, it helps when setting up and trouble-shooting.
- There is a front panel test point for the zeroed and amplified signal. This is very convenient (essential) for setting up and trouble-shooting.
- There is the option of a plug-in resistor, R16, to give a feedback derivative (lead or D) in the output of the feedback amplifier.
- It can be set up for a current input by connecting a 240 Ohm resistor between terminals 17 and 18 with the 4-20mA switch ([SW1-4]).

Default

The feedback amplifier default set-up is 4-20mA flowing into terminal 18 and out of terminal 17, producing an output of 0 to -10V. Reversing the terminals, and hence the current flow, will not result in a 0 to +10V output. The feedback zero must be adjusted for this arrangement.

Adjusting feedback amp for 4-20mA input and 0 to -10V output

- Set the feedback gain to minimum (fully counter clockwise). The trimpot has 15 turns and will click when minimum is reached.
- Connect terminal 17 to terminal 26 (ground).
- Connect the positive of a variable DC power supply to terminal 18 and the negative to terminal 26.
- Connect a digital multimeter (DMM), on DC Volts, between the front panel feedback amp and ground test points.
- Set the variable supply to 0.96V.

- Adjust the feedback amp zero trimpot until the DMM reads 0.00V.
- Set the variable supply to 4.80V.
- Adjust the feedback gain trimpot until the DMM reads -10.00V.
- Set the variable supply to 0.96V again and check the feedback test point is still 0.00V. Trim if necessary and check the 4.80V setting again.

6.2 Input 1

An input to the error amplifier: This input is $\pm 10V$ non-inverting and has two important features:

- It has a scale pot on its input that enables large inputs to be scaled down to match smaller signals on other inputs. Scale range is 10 to 100%. Set fully clockwise (FCW), an input of 100V can match a 10V signal on the other inputs. Note that the maximum permissible input voltage is $\pm 95V$.
- It has a switch selectable lag (SW4-2) of 55mS that can be used to remove transients from the input signal that could cause unwanted rapid movement in the output.

Input 1 is well suited to be a command because of these two features. If input 1 is used for feedback, be sure the lag is switched off. Input resistance after the scale pot is 94k Ohms.

6.3 Input 2

An input to the error amplifier: This input is non-inverting. It is switch selectable (SW5) between 4-20mA and $\pm 10V$. The 4-20mA converter produces 0 to +10V for 4 to 20mA input. R34 connects from the output of the converter to the input of the servo amp when 4-20mA is selected. Plug-in input resistor R34, of 100k Ohms, gives a nominal 0 to 10V input signal range when V rather than 4-20mA is selected. Input 2 is suitable for command or feedback. R34 can be increased to give a larger input range.

6.4 Input 3

An input to the output summing and limiting amplifier via a plug-in resistor, R33. A typical use for this input is command feed forward. With R33 at 10k Ohm, a $\pm 10V$ input will produce $\pm 100%$ valve drive. Increasing R33 reduces the valve drive.

7 Output configuration

The output signal is 4-20mA. No other signal type can be selected. Permissible load range is 0 Ohm to 500 Ohm. Nominal null output is 12mA.

The output amplifier is limited to approximately 105% of the selected full scale output. If both the proportional and integrator stages are saturated, the output will not be twice the selected full scale but still only 105% of full scale.

8 Step push button

The step push button (SW3) injects -50% valve drive disturbance into the output. When released, the valve drive reverts to its original level. This feature is useful for closed loop gain optimisation.

9 P-I selection

For position closed loops, initially select only P (SW6-2). For pressure or velocity loops select I (SW6-4) initially and then P. See paragraph 12 below for more detail. For a complete discussion of P and I control, see the G122-202 servoamplifier Application Notes (part no C31015).

10 Integrator input

The servoamplifier has a unity gain input error amplifier followed by two parallel stages, one a proportional amplifier and the other an integrator. The outputs of these two stages can be switched to the output power amplifier (see paragraph 7 above) which then drives the valve.

The input to the integrator stage can be switch selected (SW4-1) from either the output of the error amplifier, I in = E, or the output of the proportional stage, I in = P. The latter arrangement is used in the G122-202. It is beyond the scope of these Application Notes to detail the benefits of each arrangement. If you have experience with the G122-202, I in = P would seem to be an easy choice.

11 P only gain

For position loops select only P control (SW6-2). Input a step disturbance of 50% valve current with the step push button (SW3). Adjust the P gain for the required stability, while monitoring the front panel valve test point, or the feedback signal. The gain range of the proportional amplifier can be moved by changing the plug-in resistor R17. The value loaded when shipped is 100k Ohms, which gives a 1 to 20 range. Selecting 200k Ohms will give 2 to 40. The circuit will function correctly with the value of R17 between 100k Ohms and 10M Ohms.

Note that as P gain is increased, the movement due to the step push button decreases.

12 P and I gains together

If you are inexperienced with integral control the following set-up method is a good starting point.

- I in = E: Initially select only I (SW6-4). Press the step push button (SW3). Increase I gain until one overshoot in the feedback signal is observed.

Next select P (SW6-2) and I (SW6-4) together and increase the P gain to reduce the overshoot.

For the I in = E arrangement the P and I sequence could be reversed. i.e.: adjust P first, followed by I.

- I in = P: For an I in = P arrangement, only the "P followed by I" sequence of adjustment can be used.

For a more thorough discussion see G122-202 Application Notes (part no C31015).

13 I limit

The contribution from the integrator to the output amplifier can be reduced by selecting I limit on (SW6-3). When this switch is on the integrator contribution is reduced to approximately 15% of the level when it is off. This feature is useful in a position loop that may require integral control to achieve the required steady state accuracy. The limited integral control removes valve null error when the final position is reached. It is also useful in a pressure loop to limit overshoot, if the valve drive saturates.

14 Dither

The dither frequency is fixed at 200Hz and the level is adjustable with the front panel pot to $\pm 10\%$ of valve drive, regardless of the type and level of valve drive selected. It can be turned on or off with ([SW1-3]). Dither is seldom needed in a position loop but can be beneficial in pressure or velocity loops. Increase dither until it can just be detected in the controlled variable, such as pressure or velocity. Dither can compromise valve life, so it should be kept to a minimum.

15 Enable

A relay on the circuit card needs to be energised to connect the output stage to its screw terminal and to un-clamp the integrator. The clamp prevents integrator wind-up when the loop is not operating. Supply 24V to the appropriate terminal to energise the relay. The enable switch ([SW1-2]) on the circuit card can be set to permanently energise the relay and provide a permanent enable.

16 In position

When the valve drive signal falls below $\pm 10\%$ of full scale signal, the "in position" signal goes true and provides an opto-isolated current path between the + and - terminals. This can be connected to a PLC to initiate the next step in a control sequence. Do not apply more than 40V to the + terminal and ensure the load on the - terminal is less than 20mA.

The "in position" signal is not relevant for a velocity loop.

17 Withdrawing the circuit card from its case

The circuit card needs to be withdrawn from its case to set the selector switches, change the plug-in resistors and operate the step push button.

To do this, push one cover release tab with a pen or screwdriver, while gently pulling on the top cover on that side. The cover will release approximately one mm. Repeat on the second tab on that side. Repeat on the other side and then withdraw the cover and circuit card until the required switches are exposed. The rigidity of the connecting wires will hold the circuit card in position while changes are made.

18 Specifications

Function:	P, I, or P & I, switch selectable
Input 1:	Scaled to 95V max with switch selectable lag of 55mS.
Input 2:	Switch selectable. 4-20mA 240R load, for 0 to +10V on R34. Or 0 to $\pm 10V$ direct onto R34. R34 is plug-in, 100K nominal.
Input 3:	R33 plug-in. $\pm 10V$ gives $\pm 100\%$ valve drive when R33 = 10k Ohm, $\pm 10\%$ when R33 = 100k Ohm.
Feedback input:	Differential 4-20mA or $\pm 10V$, switch selectable $\pm 15V$ max. R in 100k – $\pm 10V$ R in 240R – 4-20mA
Feedback amp:	Zero, $\pm 10V$. Gain, 1 to 10. Derivative (velocity) feedback via plug-in resistor R16 and fixed capacitor.
Transducer excitation:	+10V @ 10mA max.
Error amp:	Unity gain. Bias $\pm 1.5V$.
Proportional amp gain:	1 to 20.
Integrator gain:	1 to 45 per second.
Integrator input:	Switch selectable from output of unity gain error amp or proportional gain amp
Enable:	Relay, +24V @ 8mA, 17 to 32V.
Output amp:	Fixed at 4-20mA. Nominal null output is 12mA. Permissible load range is 0 Ohm to 500 Ohm.
Step push button:	-50% valve drive disturbance.
Valve supply:	Terminal 23, 300mA max.
In position:	$\pm 10\%$ of valve drive. 20mA and 40V max output to PLC.
Front panel indicators:	Vs, internal supply – green Valve drive positive – red negative – green Enable – yellow In position – green
Front panel test points:	Valve $\pm 10V$ (regardless of output signal selection) Feedback amplifier output signal 0V
Front panel trim pots: (15 turns)	Input 1 scale Error amp bias P gain I gain Dither level Feedback amp gain Feedback amp zero

Dither:	200 Hz fixed frequency. $\pm 10\%$ valve drive. Switch selectable on/off
Supply:	Terminal 1, 24V nominal, 22 to 28V 75mA @ 24V, no valve current, 200mA @ 100mA valve current
$\pm 15V$ output:	Terminals 14 and 15, $\pm (110mA - \text{max valve current})$
Wire size range:	0.2mm ² to 2.5mm ² (24AWG to 12AWG)
Recommended supply protection:	M205, 250mA T (slow blow) fuse compliant to IEC 127-2 sheet 3
Mounting:	DIN rail IP 20
Temperature:	0 to +40°C
Dimensions:	100W x 108H x 45D
Weight:	180g
CE mark:	EN50081.1 emission EN61000-6-2 immunity
C tick:	AS4251.1 emission

19 Internet

www.moog.com/dinmodules

20 Block-wiring diagram

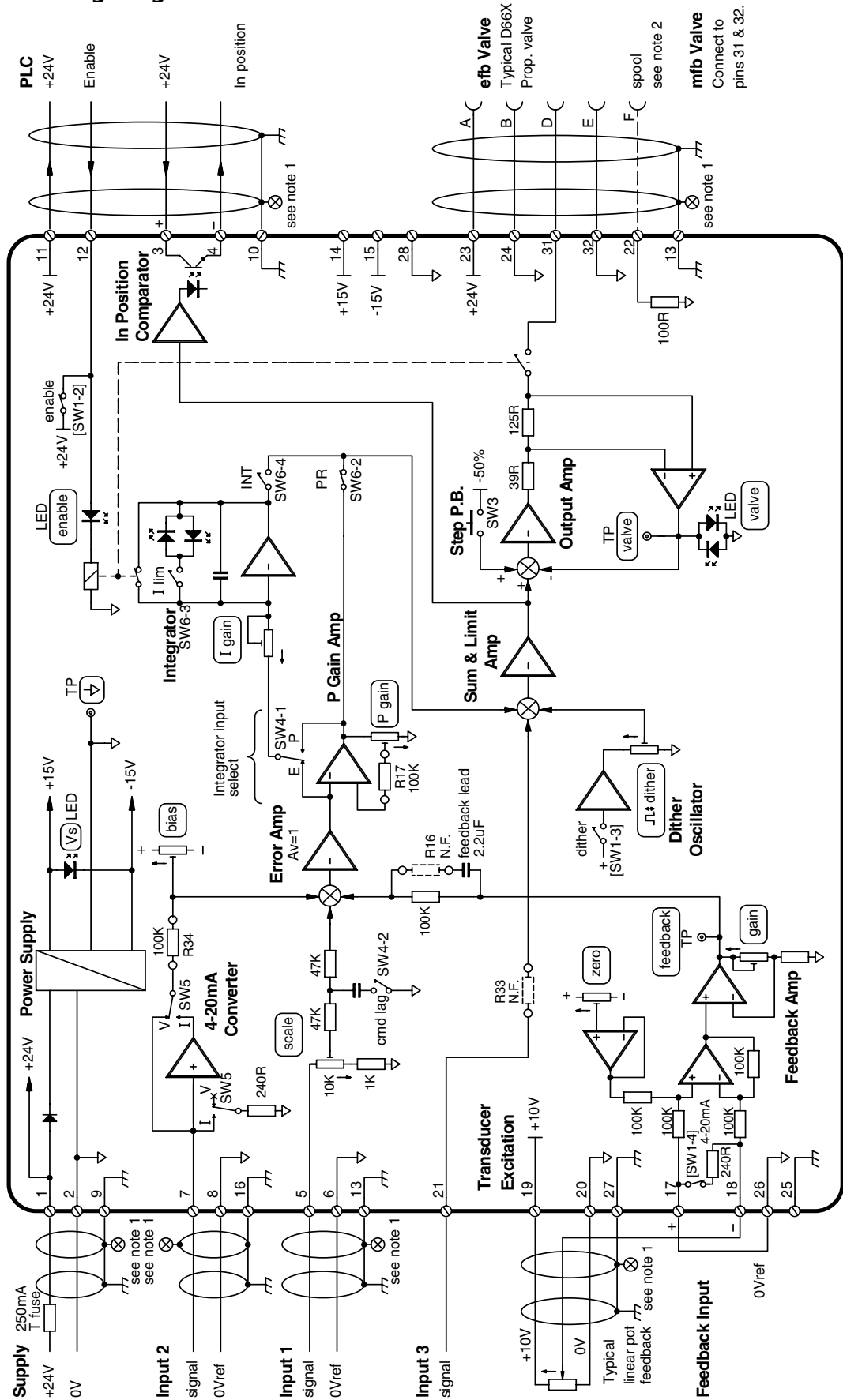

Note: 1. Connect cable screen to enclosure cable gland or chassis ground terminal on G122-829-003.

Note: 2. Connect spool (pin F) to terminal 22, only if the spool signal is a current.

Note: 3. Switches shown in default shipping mode.
Note: 4. [] indicates bottom board.

MOOG

Industrial Controls Division. Moog Inc., East Aurora, NY 14052-0018. Telephone: 716/652-3000. Fax: 716/655-1803. Toll Free 1-800-272-MOOG.
 Moog GmbH. Germany. Telephone: 07031-622-0. Fax: 07031-622-100.
 Moog Sarl. France. Telephone: 01 45 60 70 00. Fax: 01 45 60 70 01.
 Moog Australia Pty. Ltd. Telephone: 03 9561 6044. Fax: 03 9562 0246.

Moog pursues a policy of continuous development and reserves the right to alter designs and specifications without prior notice. Information contained herein is for guidance only and does not form part of a contract.

Australia: Melbourne, Sydney, Brisbane ■ Austria: Vienna ■ Brazil: São Paulo ■ Denmark: Birkerød ■ England: Tewkesbury ■ Finland: Espoo ■ France: Rungis ■ Germany: Böblingen, Dusseldorf ■ Hong Kong: Shatin ■ India: Bangalore
 Ireland: Ringaskiddy ■ Italy: Malnate (VA) ■ Japan: Hiratsuka ■ Korea: Kwangju-Kun ■ Philippines: Baguio City ■ Singapore: Singapore ■ Sweden: Askim ■ USA: East Aurora (NY)