

**Active Cartridge Valves – 2/2 Way**  
Series NG16–NG100

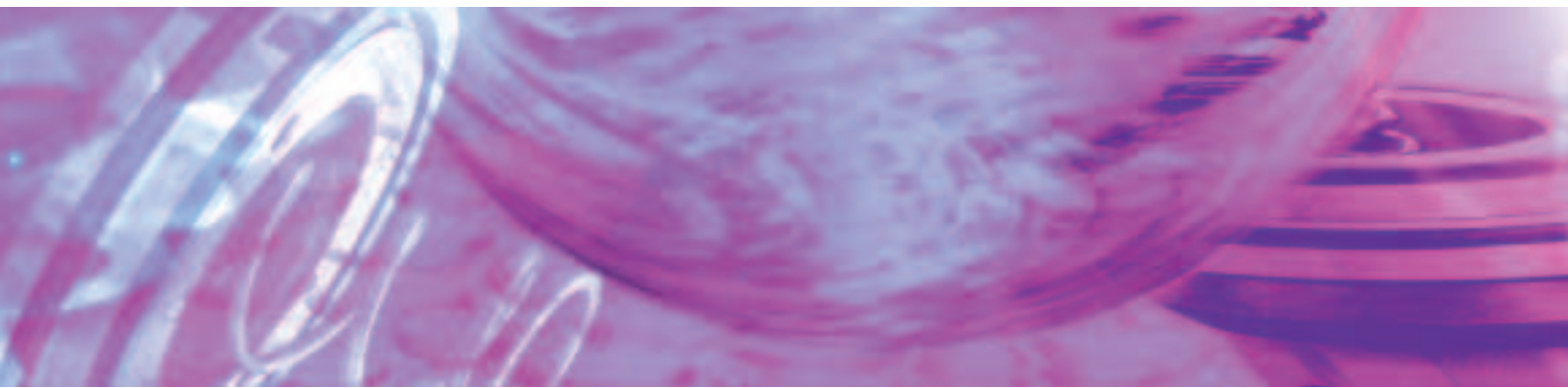
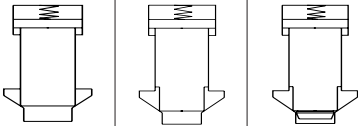
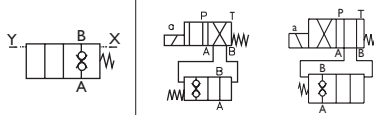

# Table of Contents

Designation	Symbol	Page
General Description		4
Features and Types of Cones and Sleeves		5
Specifications and Characteristic Parameters		6
Performance Data		7-9
Standard Models X-Cone, S-Cone, T-Cone		10-12
Standard Models Covers		13
Typical Orifice Characteristics		14
Dimensions Hydraulically Operated, Solenoid Operated		15-16
Dimensions Cavity and Porting Pattern as per DIN 24342		17
Ordering Information		18-20
Configuration		21
Spare Parts		22

This catalogue is for users with technical knowledge. To ensure that all necessary characteristics for function and safety of the system are given, the user has to check the suitability of the products described herein. In case of doubt please contact Moog Hydrolux.

## General Description

Moog Hydrolux's Active Cartridge valve was designed to eliminate many of the limitations of Standard Cartridge Valves. The Active Cartridge contains an additional control area that provides more robust control of switching pressure for high speed and response machines where low system pressure can delay closing times. In essence, Active Cartridges have a double acting pilot piston for 4-way directional control of the cone or poppet, whereas a Standard Cartridge uses a single acting piston for 3-way control.

As a result, the Active Cartridge can offer improvements in:

- Closing time
- Opening time
- Closing under load

An Active Cartridge may be used for the following functions:

- Hydraulically pilot operated check or direction control
- Solenoid pilot operated check or direction control

**Standard Cartridge**

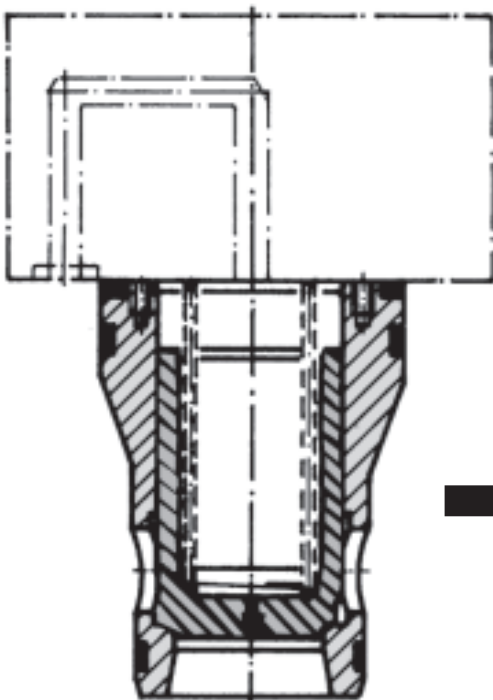

**Active Cartridge**

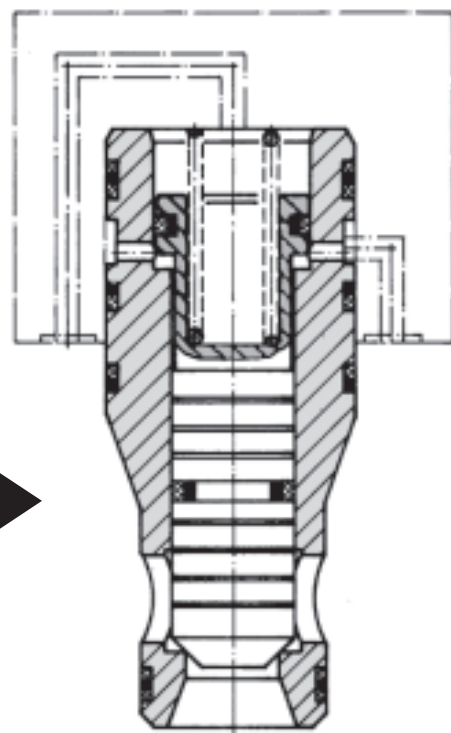

- All pilot and poppet seals create tight fit at all ports to prevent leakage in either direction
- Can operate without a spring when a defined spool position is not required and hydraulic system pressure is lost
- Cartridge can be closed by a considerably lower control pressure at X due to the larger control surface area  $A_X$  (compared to the surface area  $A_A$ )
- Opening function and velocity of the cartridge are independent of the pressure in the working ports A and B
- Ability to be equipped with X-, S-, T-, and special cones
- Sizes NG16 to NG100 per DIN 24342

## Types of Cones and Sleeves

### Sleeve A, Cone X:

An active-cartridge with sleeve-A and cone-X (differential area  $A_B = 0$ ) can be used for all directional and check functions where a larger flow area and lower pressure losses are desired.

Due to the lower throttle function ( $A_B = 0$ ) the switching operations are not as soft as when using cones with a differential area  $A_B > 0$  (Cones S and T).

With non-active control, the flow of this cartridge can only be from A to B.

Sleeve A, Cone X

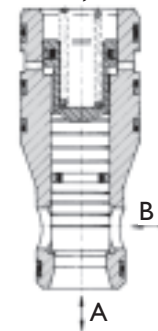

### Sleeve B, Cone S:

Used in all directional, check, and flow control functions.

Due to the cone differential area  $A_B > 0$ , the flow direction can be chosen also with non-active control.

Sleeve B, Cone S

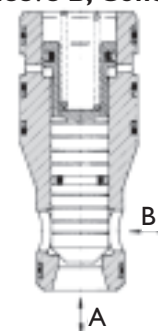

### Sleeve B, Cone T:

Cone T, with a dampening nose, can be used to avoid additional pressure peaks in tank circuits or to obtain a better adjustment of flow control valves.

Sleeve B, Cone T

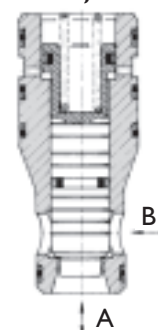

# Specifications

General Data	Value	Unit	Specifications
Designation and Symbol	—	—	2-way Seat Valve (Cartridge)
Mode of Construction	—	—	Pilot Operated Seat Valve
Manner of Mounting	—	—	Manifold Cartridge Mounting
Branch Circuit Connection	—	—	Drilling in the Manifold
Mounting Dimensions	—	—	See Mounting Dimensions Page 17
Mounting Position	—	—	Any
Flow Direction	—	—	See Cone Types Page 5
Ambient Temperature Range	min.	°C	-25°
	max.	°C	+60°
<b>Working Pressure</b>			
Inlet	min.	bar	0
	max.	bar	350
Outlet	min.	bar	0
	max.	bar	350
Temperature Range	min.	°C	-25°
	max.	°C	+80°
Viscosity Range	min.	mm <sup>2</sup> ·s <sup>-1</sup> [cSt]	2,8
	max.	mm <sup>2</sup> ·s <sup>-1</sup> [cSt]	380
Operational Viscosity	V <sub>n</sub>	mm <sup>2</sup> ·s <sup>-1</sup> [cSt]	35
Nominal Bore Size	—	mm	<b>NG16</b> <b>NG25</b> <b>NG32</b> <b>NG40</b> <b>NG50</b> <b>NG63</b> <b>NG80</b> <b>NG100</b>
Weight	m	kg	0,4 0,8 1,5 3,2 5,5 11,2 24,1 39,2
Pilot Volume (S & T Cones)	V <sub>x</sub>	cm <sup>3</sup>	2,00 8,00 17,00 29,00 77,00 191,00 285,00 494,00
Pilot Volume (X Cone)	V <sub>x</sub>	cm <sup>3</sup>	2,03 7,70 17,10 32,60 77,00 190,50 285,00 492,50

# Characteristic Parameters

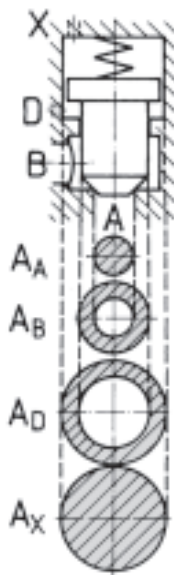

<b>Reference Surface A<sub>A</sub></b>									
	NG16	NG25	NG32	NG40	NG50	NG63	NG80	NG100	
<b>Cones S and T</b>									
Stroke mm	6,5	12,5	15,0	15,0	20	30,0	30,0	35,5	
A <sub>A</sub> mm <sup>2</sup>	123	227	452	804	1590	2642	3848	5675	
A <sub>A</sub> (Ref)	I	I	I	I	I	I	I	I	
A <sub>B</sub>	0,64	0,67	0,56	0,41	0,49	0,46	0,47	0,68	
A <sub>D</sub>	0,92	1,04	0,95	1,03	0,93	0,95	1,00	0,77	
A <sub>X</sub>	2,56	2,71	2,51	2,44	2,42	2,41	2,47	2,45	
<b>Cone X</b>									
Stroke mm	6,5	12,5	15,0	15,0	20,0	30,0	30,0	35,5	
A <sub>A</sub> mm <sup>2</sup>	201	380	707	1257	2376	3848	5674	9503	
A <sub>A</sub> (Ref)	I	I	I	I	I	I	I	I	
A <sub>B</sub>	—	—	—	—	—	—	—	—	
A <sub>D</sub>	,56	0,62	0,61	0,73	0,62	0,65	0,68	0,46	
A <sub>X</sub>	1,56	1,62	1,61	1,73	1,62	1,65	1,68	1,46	

## Direction and Check Functions

CONE-X, WITHOUT DAMPENING NOSE

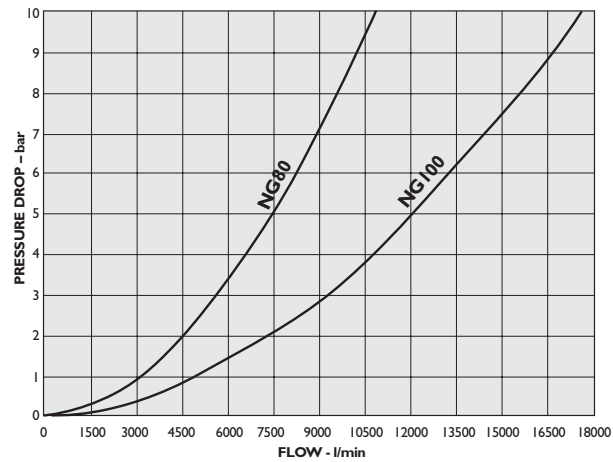
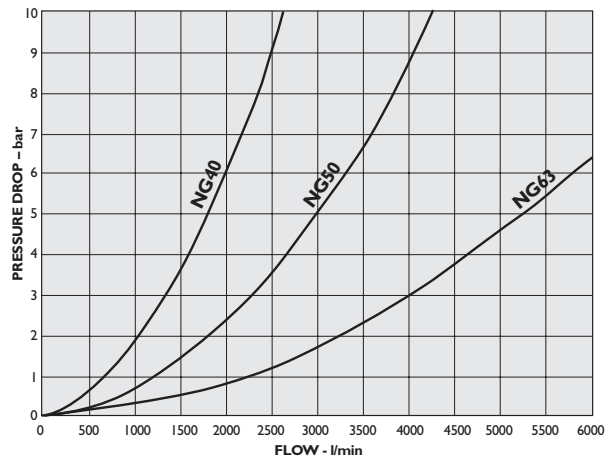
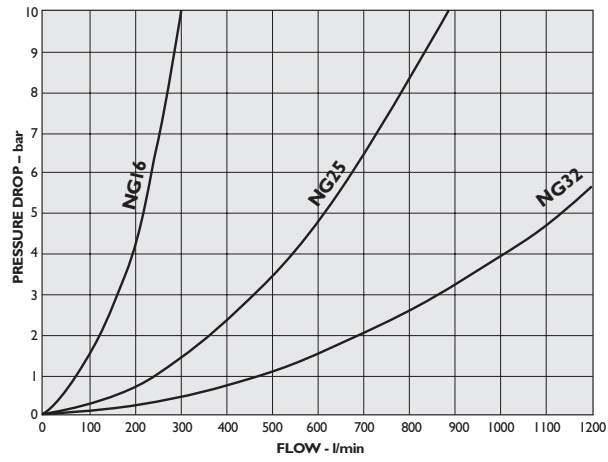

# Performance Data

## Direction; Check and Flow Control Functions

CONE-S, WITHOUT DAMPENING NOSE

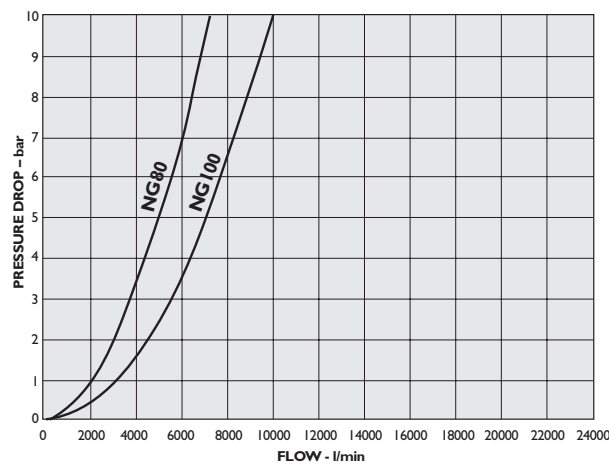
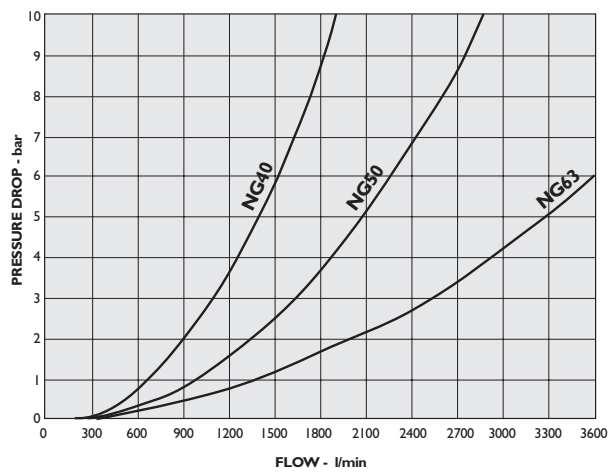
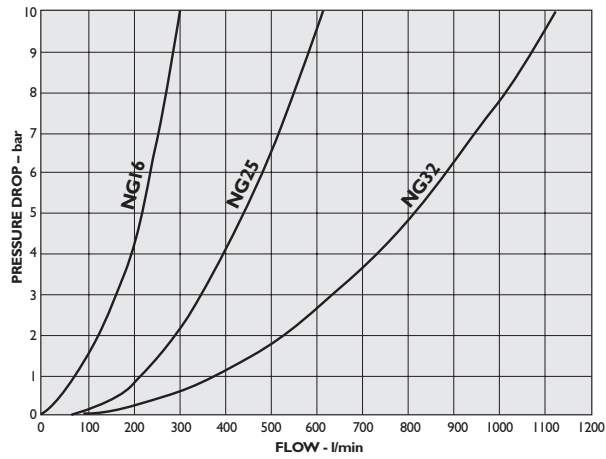

Direction; Check and Flow Control Functions

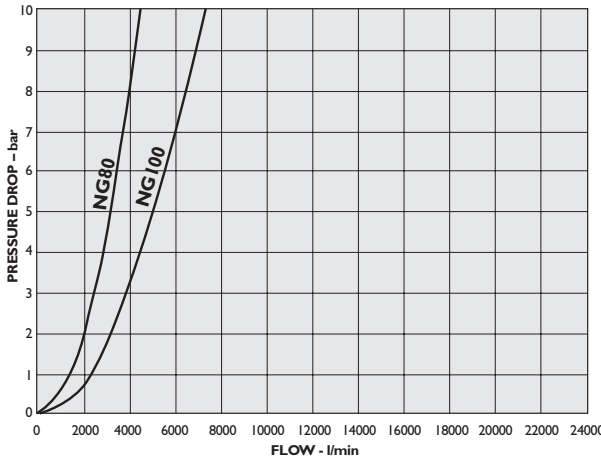
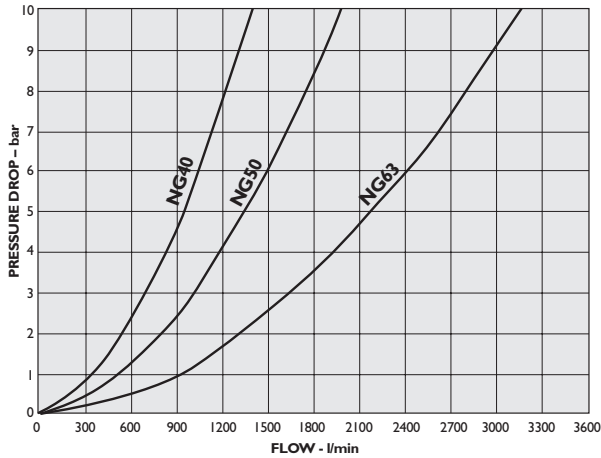
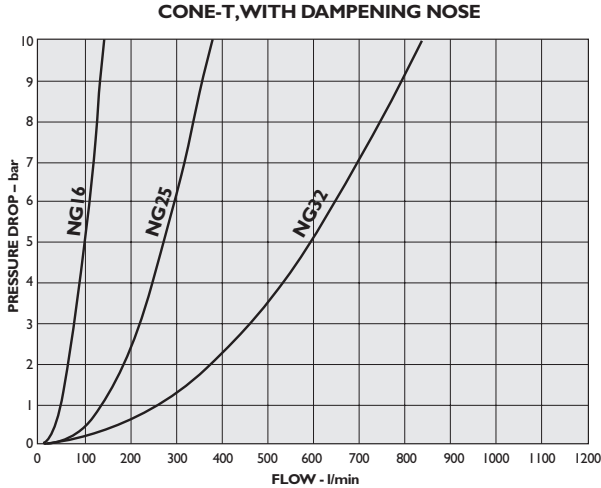

# Standard Models

## X-Cone for Direction Control and Check Functions (without dampening nose)

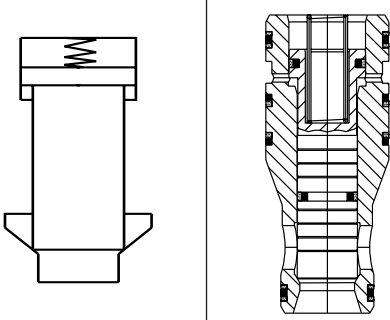
Symbol	Function	Size NG [mm]	Weight kg	Spring Rating bar	Part Designation	Part Number		
		16	0,4	1,0	CHE16A6XS	XCBI0866-000-00		
				2,0	CHE16A6XT	XCBI0867-000-00		
				4,0	CHE16A6XU	XCBI0868-000-00		
				6,0	CHE16A6XV	XCBI0869-000-00		
		25	0,8	25	0,8	1,0	CHE25A6XS	XCBI0878-000-00
						2,0	CHE25A6XT	XCBI0879-000-00
						4,0	CHE25A6XU	XCBI0880-000-00
						6,0	CHE25A6XV	XCBI0881-000-00
		32	1,5	32	1,5	1,0	CHE32A6XS	XCBI0886-000-00
						2,0	CHE32A6XT	XCBI0887-000-00
						4,0	CHE32A6XU	XCBI0888-000-00
		40	3,2	40	3,2	1,0	CHE40A6XS	XCBI1104-000-00
						2,0	CHE40A6XT	XCBI1105-000-00
						4,0	CHE40A6XU	XCBI1106-000-00
		50	5,5	50	5,5	1,0	CHE50A6XS	XCBI0901-000-00
						2,0	CHE50A6XT	XCBI0902-000-00
						4,0	CHE50A6XU	XCBI0903-000-00
		63	11,2	63	11,2	1,0	CHE63A6XS	XCBI0910-000-00
						2,0	CHE63A6XT	XCBI0911-000-00
						4,0	CHE63A6XU	XCBI0912-000-00
		80	24,1	80	24,1	1,0	CHE80A6XS	XCBI1160-000-00
						2,0	CHE80A6XT	XCBI1161-000-00
						4,0	CHE80A6XU	XCBI1162-000-00
		100	39,2	100	39,2	1,0	CHE100A6XS	XCBI0923-000-00
						2,0	CHE100A6XT	XCBI0924-000-00
						4,0	CHE100A6XU	XCBI1026-000-00

## S-Cone for Direction; Check and Flow Control Functions (without dampening nose)

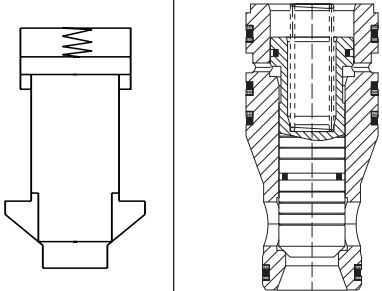
Symbol	Function	Size NG [mm]	Weight kg	Spring Rating bar	Part Designation	Part Number
		16	0,4	1,0	CHE16A6SS	XEB10870-000-00
				2,0	CHE16A6ST	XEB10871-000-00
				4,0	CHE16A6SU	XEB10872-000-00
				6,0	CHE16A6SV	XEB10873-000-00
		25	0,8	1,0	CHE25A6SS	XCB10001-000-00
				2,0	CHE25A6ST	XCB10002-000-00
				4,0	CHE25A6SU	XCB10003-000-00
				6,0	CHE25A6SV	XCB10004-000-00
		32	1,5	1,0	CHE32A6SS	XCB10889-000-00
				2,0	CHE32A6ST	XCB10890-000-00
				4,0	CHE32A6SU	XCB10891-000-00
		40	3,2	1,0	CHE40A6SS	XCB10895-000-00
				2,0	CHE40A6ST	XCB10896-000-00
				4,0	CHE40A6SU	XCB10897-000-00
		50	5,5	1,0	CHE50A6SS	XCB10904-000-00
				2,0	CHE50A6ST	XCB10905-000-00
				4,0	CHE50A6SU	XCB10906-000-00
		63	11,2	1,0	CHE63A6SS	XCB10913-000-00
				2,0	CHE63A6ST	XCB10914-000-00
				4,0	CHE63A6SU	XCB10915-000-00
		80	24,1	1,0	CHE80A6SS	XCB10919-000-00
				2,0	CHE80A6ST	XCB10920-000-00
				4,0	CHE80A6SU	XCB11078-000-00
		100	39,2	1,0	CHE100A6SS	XCB10925-000-00
				2,0	CHE100A6ST	XCB10926-000-00
				4,0	CHE100A6SU	XCB11027-000-00

# Standard Models

## T-Cone for Direction; Check and Flow Control Functions (with dampening nose)

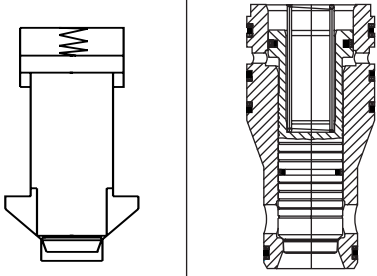
Symbol	Function	Size NG [mm]	Weight kg	Spring Rating bar	Part Designation	Part Number
		16	0,4	1,0	CHE16A6TS	XCB10874-000-00
				2,0	CHE16A6TT	XCB10875-000-00
				4,0	CHE16A6TU	XCB10876-000-00
				6,0	CHE16A6TV	XCB10877-000-00
		25	0,8	1,0	CHE25A6TS	XCB10882-000-00
				2,0	CHE25A6TT	XCB10883-000-00
				4,0	CHE25A6TU	XCB10884-000-00
				6,0	CHE25A6TV	XCB10885-000-00
		32	1,5	1,0	CHE32A6TS	XCB10892-000-00
				2,0	CHE32A6TT	XCB10893-000-00
				4,0	CHE32A6TU	XCB10894-000-00
		40	3,2	1,0	CHE40A6TS	XCB10898-000-00
				2,0	CHE40A6TT	XCB10899-000-00
				4,0	CHE40A6TU	XCB10900-000-00
		50	5,5	1,0	CHE50A6TS	XCB10907-000-00
				2,0	CHE50A6TT	XCB10908-000-00
				4,0	CHE50A6TU	XCB10909-000-00
		63	11,2	1,0	CHE63A6TS	XCB10916-000-00
				2,0	CHE63A6TT	XCB10917-000-00
				4,0	CHE63A6TU	XCB10918-000-00
		80	24,1	1,0	CHE80A6TS	XCB10921-000-00
				2,0	CHE80A6TT	XCB10922-000-00
				4,0	CHE80A6TU	XCB11079-000-00
		100	39,2	1,0	CHE100A6TS	XCB11404-000-00
				2,0	CHE100A6TT	XCB11405-000-00
				4,0	CHE100A6TU	XCB11406-000-00

## DIN Covers

Symbol	Function	Size NG [mm]	Weight lb (kg)	Part Designation	Part Number
	Normally Open or Normally Closed	16	4,0	CCE16A6RH1X06	XEB14151-000-01
		25	6,0	CCE25A6RH1X06	XEB13343-000-01
		32	8,0	CCE32A6RH1X06	XEB12705-000-01
		40	13,0	CCE40A6RH1X06	XEB13558-000-01
		50	21,0	CCE50A6RH1X10	XEB12603-000-01
		63	39,0	CCE63A6RH1X10	XEB13861-000-01
		80	57,0	CCE80A6RH1X10	XEB13959-000-01
	Externally Piloted	16	2,0	CCE16A6RH3X	XEB14065-000-01
		25	4,0	CCE25A6RH3X	XEB14150-000-01
		32	6,0	CCE32A6RH3X	XEB13410-000-01
		40	10,0	CCE40A6RH3X	XEB13287-000-01
		50	18,0	CCE50A6RH3X	XEB12923-000-01
		63	36,0	CCE63A6RH3X	XEB14463-000-01
		80	57,0	CCE80A6RH3X	XEB13462-000-01
100	60,0	CCE100A6RH3X	XEB14040-000-01		

# Typical Orifice Characteristics

The function and switching velocity of a cartridge-valve can be influenced by changes in the metering-in and metering-out flow through the pilot lines. This is achieved by changing mounting orifices as required.

The following diagram should be used for selecting the correct orifice diameter.

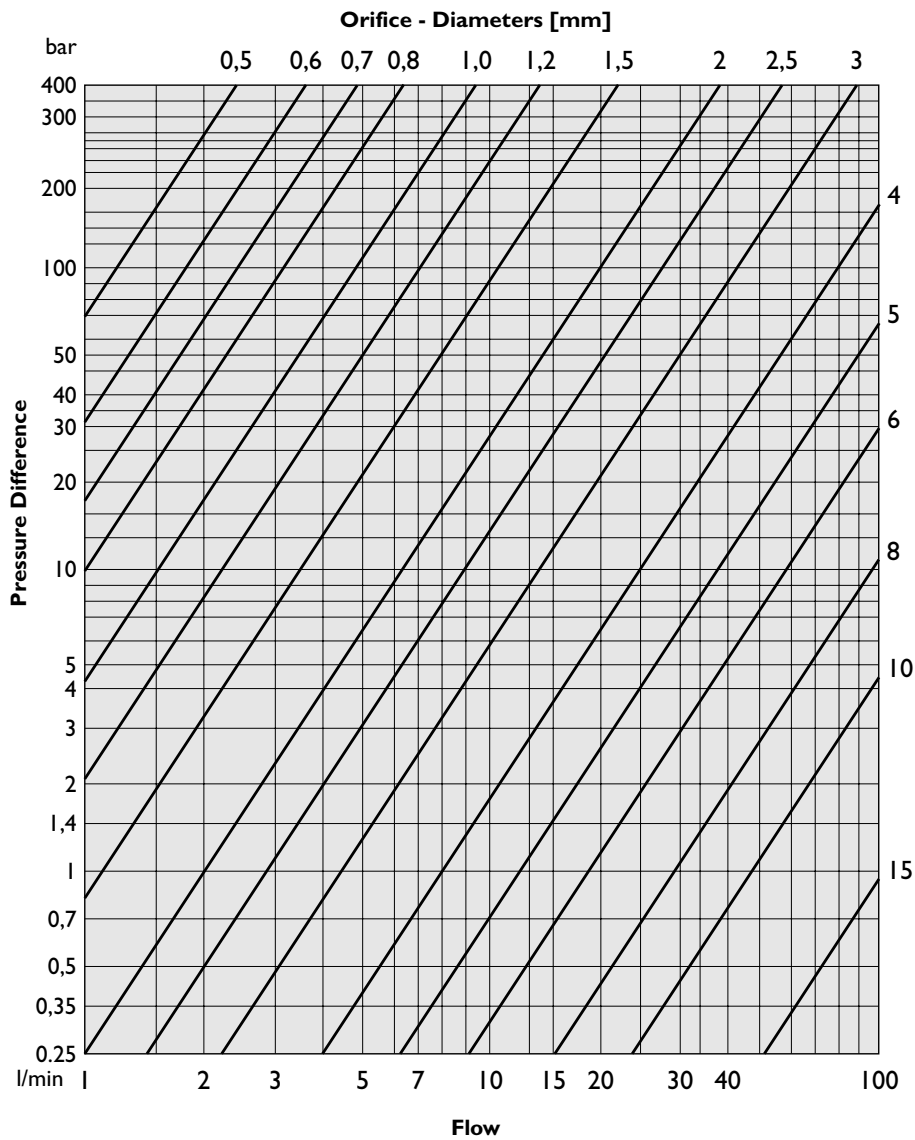

Viscosity :  $35 \text{ mm}^2 \cdot \text{s}^{-1}$  [cSt]  
 Oil temperature :  $50^\circ\text{C}$

## Hydraulically Operated Valves

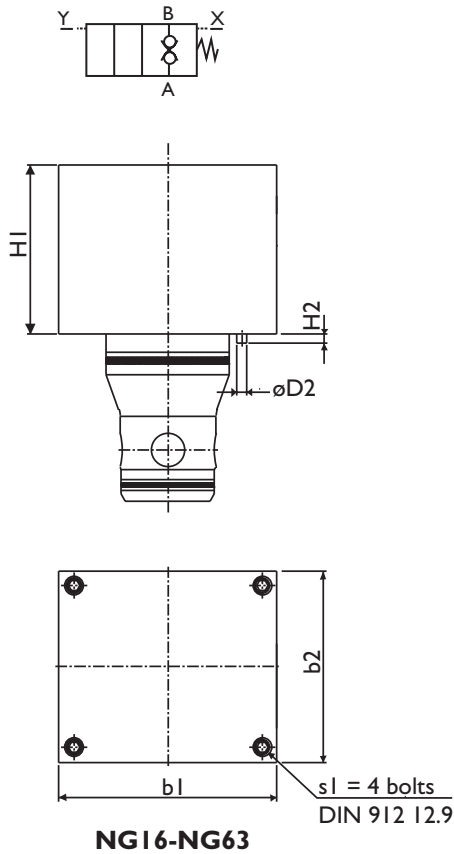

Dimensions mm	NG16	NG25	NG32	NG40	NG50	NG63	
H1	65	65	80	80	4.72 (120)	140	
H2	5	5	5	5	6	6	
D2	5	5	5	5	6	6	
b1	65	85	102	125	140	180	
b2	65	85	102	125	140	180	
s1	UNC	$\frac{5}{16}'' \times 2\frac{3}{4}''$	$\frac{1}{2}'' \times 2\frac{3}{4}''$	$\frac{5}{8}'' \times 3\frac{1}{4}''$	$\frac{3}{4}'' \times 3\frac{1}{2}''$	$\frac{3}{4}'' \times 5.0''$	$1\frac{1}{4}'' \times 6.0''$
	Metric	M8X70	M12X65	M16X80	M20X90	M20X120	M30X150
Tightening Torque	ft-lb	23	75	225	413	413	1350
	N-m	30	100	300	550	550	1800

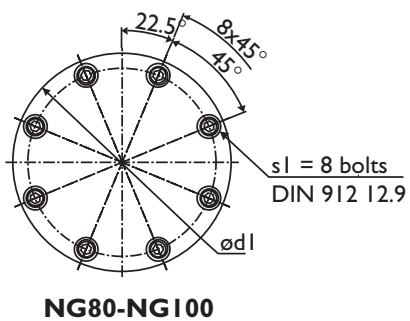

Dimensions mm	NG80	NG100	
d1	250	300	
H1	150	160	
H2	6	6	
D2	8	8	
s1	UNC	1" x 6 1/2"	1 1/4" x 6 1/2"
	Metric	M24X150	M30X160
Tightening Torque	ft-lb	675	1350
	N-m	900	1800

Note: Fastening screws are not part of the delivery.

# Dimensions

## Solenoid Operated Valves

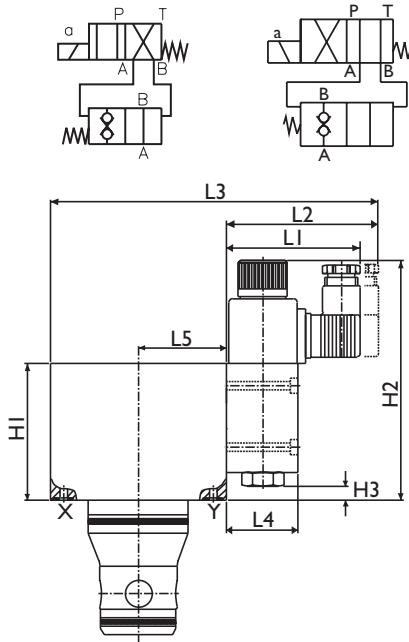

**NG16-NG63**

Dimensions mm		NG16	NG25	NG32	NG40	NG50	NG63
H1		90	90	90	90	120	40
H2		166	166	166	166	228	228
H3		8	8	8	8	5	5
L1		93	93	93	93	120	120
L2		105	105	105	105	132	132
L3		190	205	221	251	292	336
L4		6	46	46	46	96	96
L5		42,5	50	58	73	80	100
la*		γ	γ	γ	γ	γ	γ
B1		85	100	116	146	160	200
B2		65	85	100	125	140	180
B4		46	46	46	46	70	70
B5		32,5	42,5	50	62,5	70	90
B6		32,5	42,5	60,4	62,5	71,6	90
s1	UNC	$5/16" \times 3/2"$	$1/2" \times 3 3/4"$	$5/8" \times 3 3/4"$	$3/4" \times 4"$	$3/4" \times 4 3/4"$	$1 1/4" \times 6,0"$
	Metric	M8X90	M12X100	M16X90	M20X100	M20X120	M30X150
Tightening Torque	ft-lb	23	75	225	413	413	1350
	N-m	30	100	300	550	550	1800

\*la = Mounted side of pilot valve

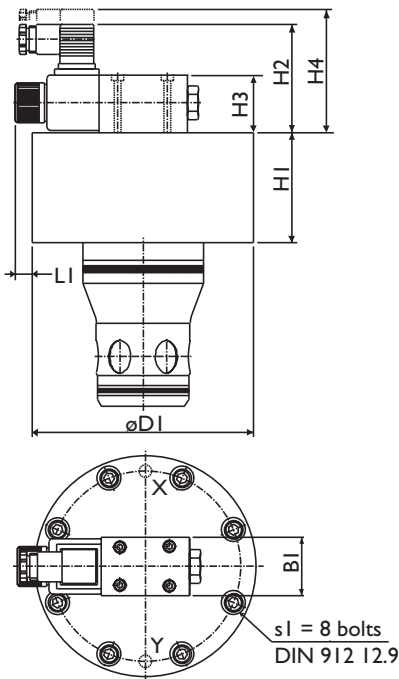

**NG80-NG100**

Dimensions in (mm)		NG80	NG100
D1		250	300
H1		150	160
H2		111	111
H3		70	70
H4		123	123
L1		44	19
B1		70	70
s1	UNC	$1" \times 6 1/2"$	$1 1/4" \times 6 1/2"$
	Metric	M24X150	M30X160
Tightening Torque	ft-lb	675	1350
	N-m	900	1800

Note: Fastening screws are not part of the delivery.

CAVITY AS PER ISO 7368

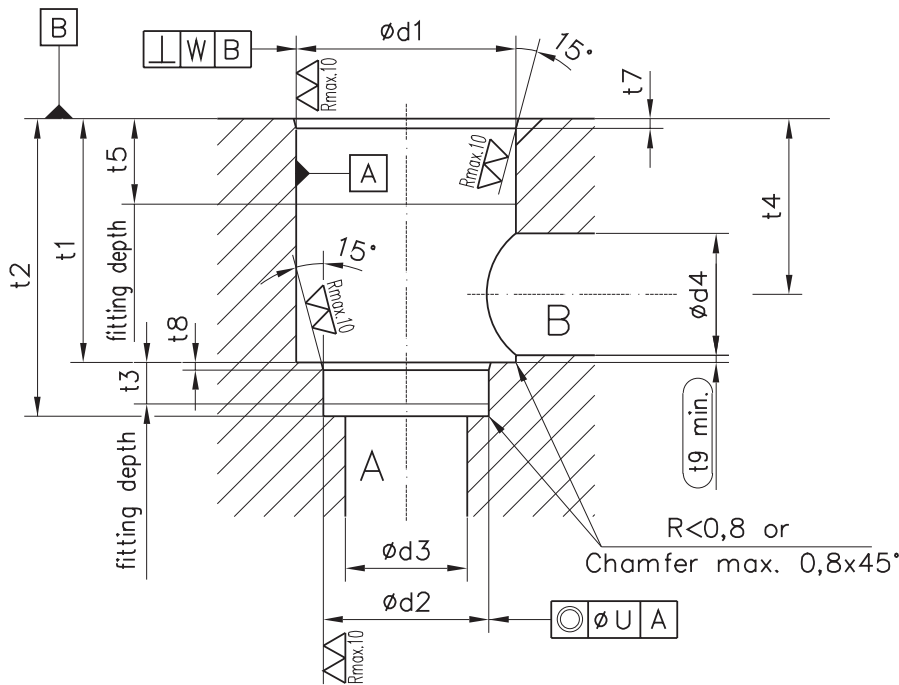

Required surface finish

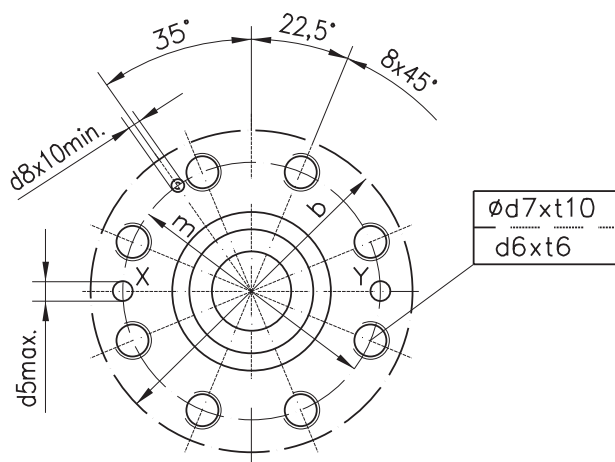
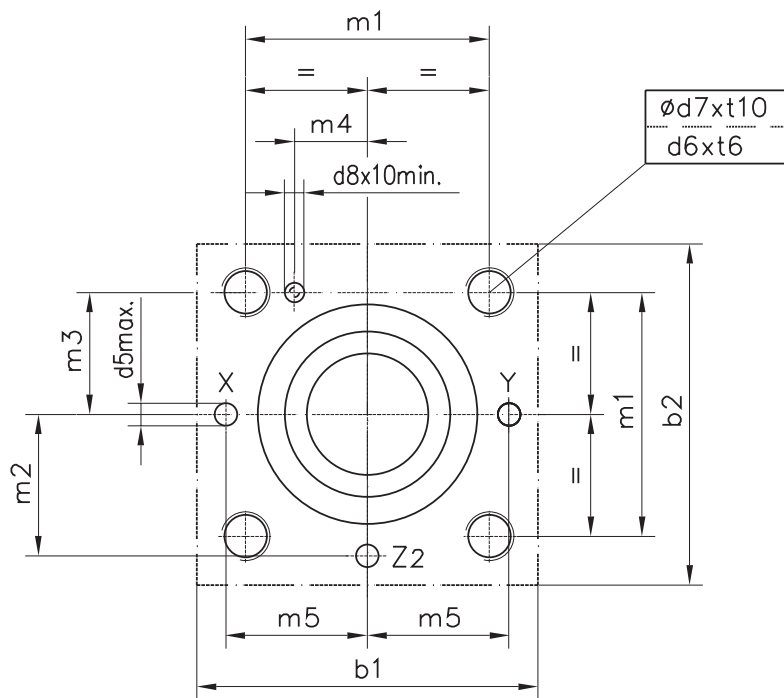
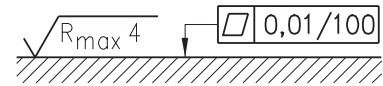

Dimension	NG16	NG25	NG32	NG40	NG50	NG63
b1	65	85	102	125	140	200
b2	65	85	102	125	140	180
d1 <sup>H7</sup>	32	45	60	75	90	120
d2 <sup>H7</sup>	25	34	45	55	68	90
d3	16	25	32	40	50	63
d4	16	25	32	40	50	63
d4 <sub>max.</sub>	25	32	40	50	63	80
d5 <sub>max.</sub>	4	6	8	10	10	12
d6	M8	M12	M16	M20	M20	M30
d7	6,8	10,2	14	17,5	17,5	26,5
d8 <sup>H13</sup>	4	6	6	6	8	8
m1 ±0,2	46	58	70	85	100	125
m2 ±0,2	25	33	41	50	58	75
m3 ±0,2	23	29	35	42,5	50	62,5
m4 ±0,2	10,5	16	17	23	30	38
m5 ±0,2	25	33	41	50	58	75
t1 +0,1	43	58	70	87	100	130
t2 +0,1	56	72	85	105	122	155
t3	11	12	13	15	17	20
t4	34	44	52	64	72	95
t4 at d4 <sub>max.</sub>	29,5	40,5	48	59	65,5	86,5
t5	20	30	30	30	35	40
t6	14	20	26	33	33	50
t7	2	2,5	2,5	3	4	4
t8	2	2,5	2,5	3	3	4
t9	0,5	1,0	1,5	2,5	2,5	3
t10	17	24	31	38	38	56
U	0,03	0,03	0,03	0,05	0,05	0,05
W	0,05	0,05	0,1	0,1	0,1	0,2

Dimension	NG80	NG100
b <sub>max.</sub>	250	300
d1 <sup>H7</sup>	145	180
d2 <sup>H7</sup>	110	135
d3	80	100
d4	80	100
d4 <sub>max.</sub>	100	125
d5 <sub>max.</sub>	16	20
d6	M24	M30
d7	21	26,5
d8 <sup>H13</sup>	10	10
t1	175	210
t2 +0,2	205	245
t3	25	29
t4	130	155
t4 at d4 <sub>max.</sub>	120	142,5
t5	40	50
t6	39	50
t7	5	5
t8	5	5
t9	3	5
t10	45	56
m ±0,3	200	245
U	0,05	0,05
W	0,2	0,2

# Ordering Information

## Active Cartridge Only

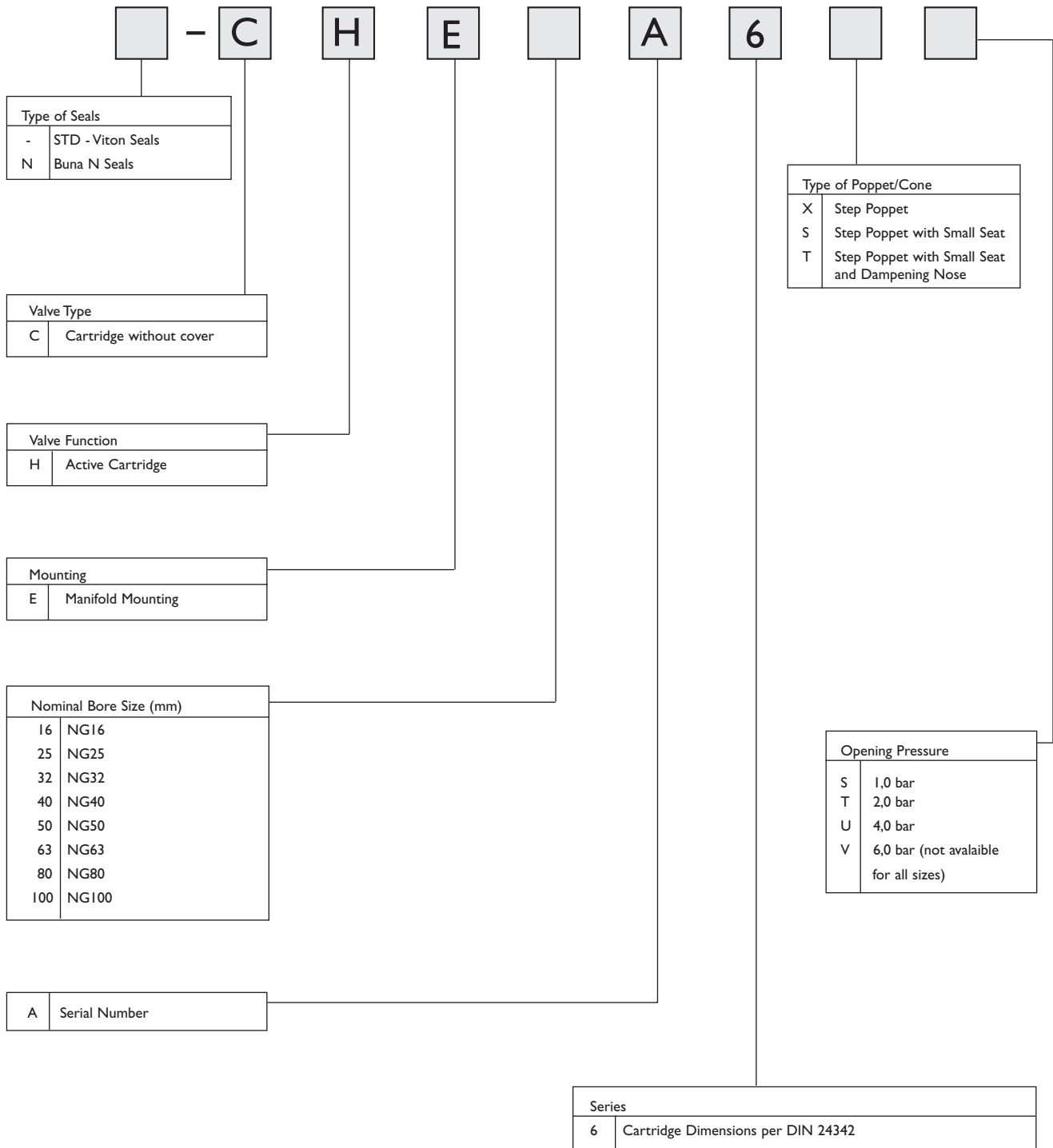

## Active Cartridge Covers Only

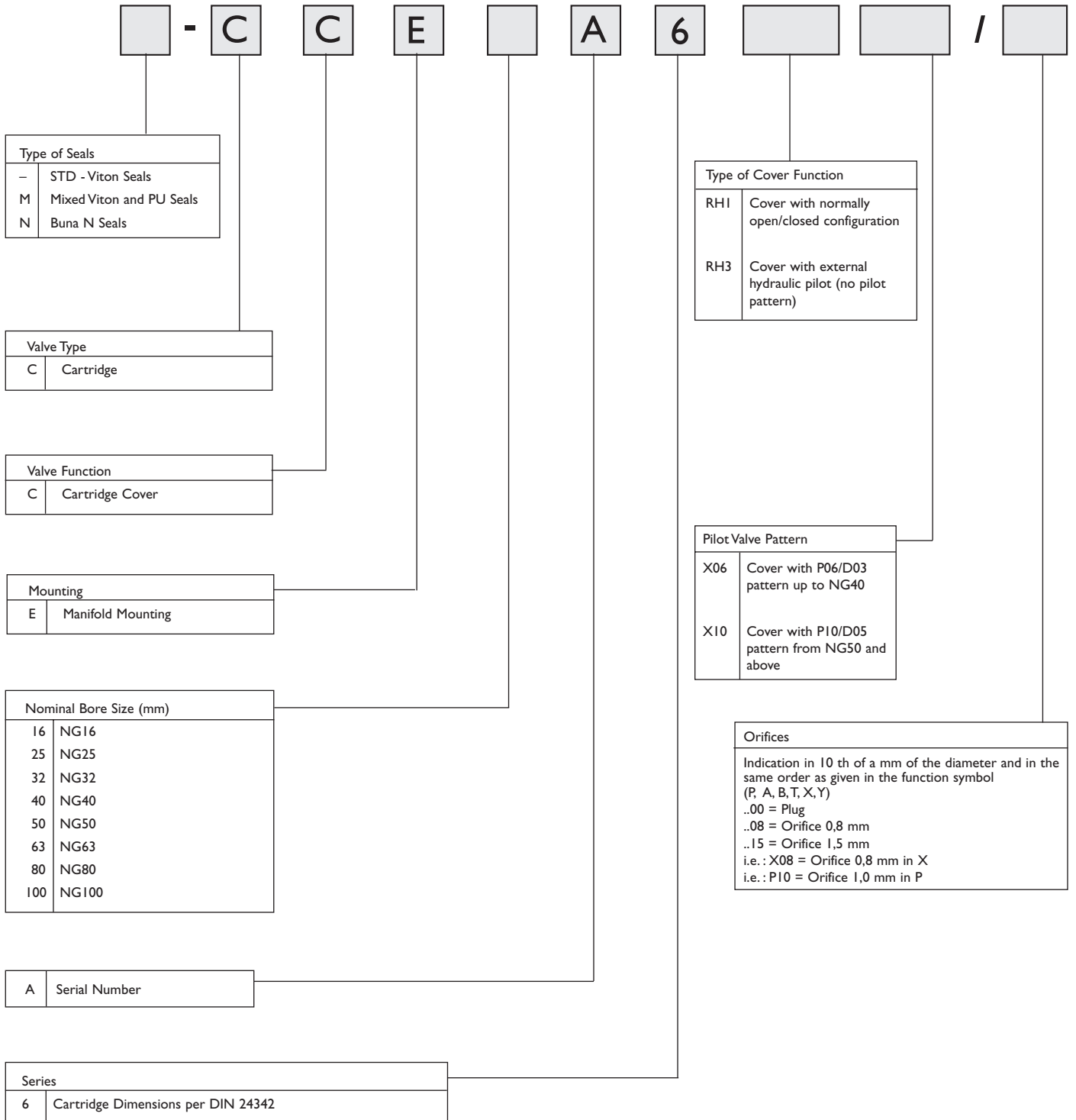

# Ordering Information

## Aktiv Cartridge complete

[ ] -	R	H	E	A	6	W	X	/	
-------	---	---	---	---	---	---	---	---	--

<b>Type of Seals</b>	
without Des.	FPM/FKM (Standard)
M	FPM/FKM + PUR
N	NBR

<b>Valve Type</b>	
R	Activ Cartridge with Cover

<b>Valve function</b>	
H	Activ Cartridge

<b>Mounting</b>	
E	Manifold mounting

<b>Nominal Bore Size (nn)</b>	
16	NG 16
25	NG 25
32	NG 32
40	NG 40
50	NG 50
63	NG 63
80	NG 80
100	NG 100

A	Serial Number
---	---------------

<b>Spring</b>	
S	1,0 bar
T	2,0 bar
U	4,0 bar
V	6,0 bar (not available for all sizes)

<b>Series</b>	
6	mounting dimensions as per DIN 24342 / ISO 7368

<b>Type of Poppet / Cone</b>	
X	Step Poppet
S	Step Poppet with small Seat
T	Step Poppet with small Seat and dampening nose
-	special poppet on request

<b>Modifications</b>	
OP	without pilot valve
W106	Cover with mounting face dimension P06 for solenoid pilot control.
W110	Cover with mounting face dimension P10 for solenoid pilot control.
Indication in 10 <sup>th</sup> of a mm of the diameter and in the same order as given in the function symbol (P,A, B, T, X, Y) ..00 = Plug ..08 = Orifice 0,8 mm ..15 = Orifice 1,5 mm i.e.: X08 = Orifice 0,8 mm in X i.e.: P10 = Orifice 1,0 mm in P	

<b>Electrical connection (optional)</b>	
without Des.	connection as per DIN 43650 without plug
1	Cube plug recommended by DIN 43650

<b>Solenoid supply (only for valves with pilot operated solenoid)</b>	
A	12 VDC
B	24 VDC
M	110 VAC 50/60 Hz
N	220 VAC 50/60 Hz

<b>Function</b>	
1	Active opening with energised solenoid.
2	Active closing with energised solenoid.
3	Externally pilot operated.

<b>Pilot connection</b>	
X	x trough mounting surface / y through mounting surface

  

<b>Opening</b>	
W	activ

  

<b>Ratio see page 6</b>	
1	NG 16
2	NG 25
3	NG 32
4	NG 40
5	NG 50
6	NG 63
7	NG 80
8	NG 100
Factory determined!	

Subject to technical changes

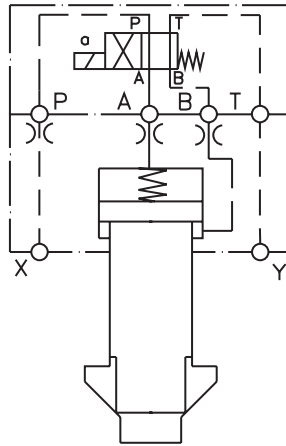

**RHE...WX1..**  
**(Normally Closed - Energize solenoid to open)**

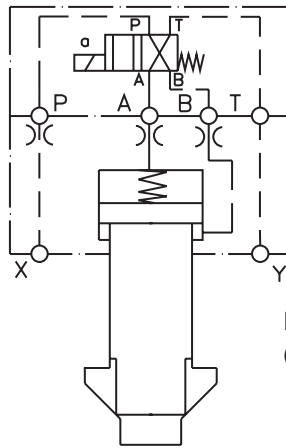

**RHE...WX2..**  
**(Normally Open - Energize solenoid to close)**

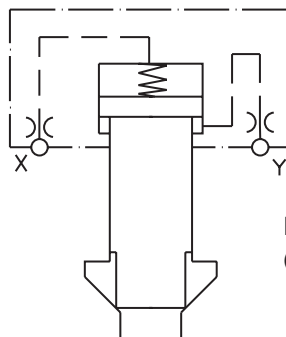

**RHE...WX3..**  
**(externally hydraulically operated)**

# Spare Parts

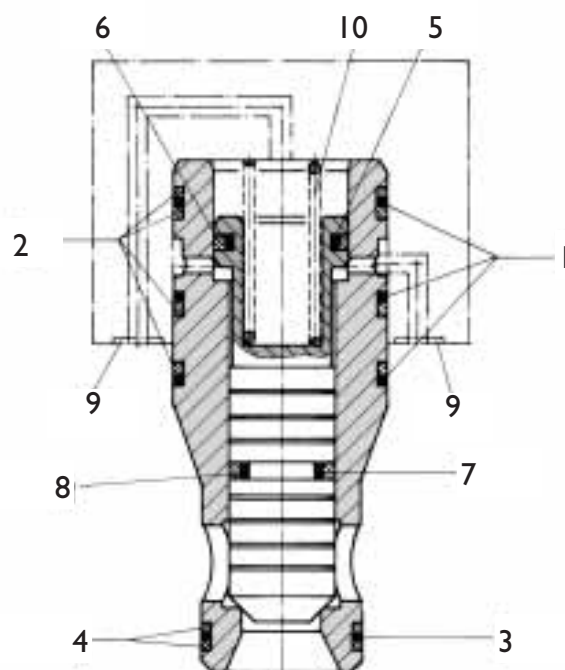

Pos.	Designation	Order Number								
			NG16	NG25	NG32	NG40	NG50	NG63	NG80	NG100
	Seal Kit	XEB	12240	12241	12242	12243	12244	12245	12246	12247
1	O-Ring 80 Shore	X980-	02024	02129	02227	02231	02338	02347	02430	02439
2	Back-Up Ring	X780-	18024	18129	08227	18231	18338	08348	08431	18439
3	O-Ring 80 Shore	X980-	02020	02122	02222	02225	02229	02338	02344	02427
4	Back-Up Ring	X780-	08020	18122	18222	18225	18229	18338	18344	18427
5	O-Ring 70 Shore	X980-	02112	02116	02123	02222	02228	02336	02343	02425
6	Turcon Glyd Ring	X780-	40200	40280	40380	40500	40700	40900	41100	41330
7	O-Ring 70 Shore	X980-	02109	02113	02118	02123	02224	02228	02335	02343
8	Turcon Glyd Ring	X780-	40160	40220	40300	40380	40550	40700	40850	41100
9	O-Ring 80 Shore	X980-	02010	02012	02013	02112	02112	02116	02215	02220
	<b>Springs</b>									
10	Spring S - 1,0 bar	XEF	10006	10013	10138	10106	10037	10044	10051	10058
10	Spring T - 2,0 bar	XEF	10007	10014	10140	10105	10038	10045	10052	10059
10	Spring U - 4,0 bar	XEF	10008	10015	10191	10104	10173	10046	10052 10250	10059 10253
10	Spring V - 6,0 bar	XEF	10009	10015 10016	—	—	—	—	—	—

**Order examples:**

O-Ring Item 5 for NG25  
Order number: X980-02116

Spring 2,0 bar Item 10 for NG25  
Order number: XEF10014



Australia

Brazil

China

Denmark

England

Finland



France

Germany

India

Ireland

Italy

Japan

Korea

Luxembourg

Philippines

Singapore

Spain

Sweden

USA

**MOOG**  
**HYDROLUX**

MOOG HYDROLUX S.à.r.l.

1, rue de l'Acierie

L-1112 LUXEMBOURG

Tel: (+352) 40 46 40-1

Fax: (+352) 40 46 40-909

E-mail: [administration@moog.lu](mailto:administration@moog.lu)