

AC6349

1 inch through-bore various circuit configurations

Description

A slip ring capsule can be used in any electromechanical system that requires unrestrained, intermittent, or continuous rotation while transferring power and / or data.

The AC6349 provides an economical, readily available solution when a compact through-bore configuration is required. This unit provides a 1 inch through-bore for routing hydraulic or pneumatic lines and a compact 3.1 inch outside diameter for minimal space applications. The 15 amp circuits are available in 6, 12, 18 and 24 ring configurations in 4 housing lengths. Similar in design to our very popular AC4598, this design features long life, fiber brush contact technology for ultimate performance in many challenging applications. Fiber brushes do not require lubrication and produce virtually no wear debris, for maintenance free, life time operation.

Features

- 1 inch bore
- 6, 12, 18 and 24 circuit models
- Precious metal contacts
- 15 amp rings
- Precision ball bearings for long life
- Speeds up to 250 rpm continuous
- Compact size
- Sealed units available
- Flying leads
- Fully compatible with both analog and TTL control level signals
- Rugged black anodized aluminum construction

Benefits

- Unique signal handling performance with minimal electrical circuit noise
- Tight packaging to fit in the most demanding space constraints
- Low torque to minimize system torque budget
- Rapid delivery



Typical Applications

- Packaging / wrapping machinery
- Semiconductor handling systems
- Industrial machinery
- Robotics

Slip Rings With Through-Bores

AC6349 Specifications		Options
Operating Speed	250 rpm* continuous	<ul style="list-style-type: none"> • Steel bearings • Gold - plated rings • Seals • Long leads • IP 65 rated slip ring available (P/N AC6875), see page 21
Number of Circuits	6, 12, 18, or 24	
Lead Length	20 inch standard	
Lead Size / Type	14 gauge, white with tags	
Voltage	440 VAC	
Operating Temp.	-40°C to +80°C	
Contact Material	Silver-on-silver	
Current Rating	15 amps / circuits	
Circuit Resistance	200 milliohms with 12 inch leads	
Electrical Noise	60 milliohms max. @ 6 VDC 50 milliamps when running @ 5 rpm	
Environmental	Splash and dust seal optional	

*Please note that the operational life of the unit is dependent upon rotational speed, environment and temperature.

Part Number	Length "A"
AC6349 - 6	2.9 inch (73,7 mm)
AC6349 - 12	4.1 inch (104,1 mm)
AC6349 - 18	5.3 inch (149,7 mm)
AC6349 - 24	6.5 inch (165,1 mm)

Standard units are not sealed.

AC6349 Dimensions

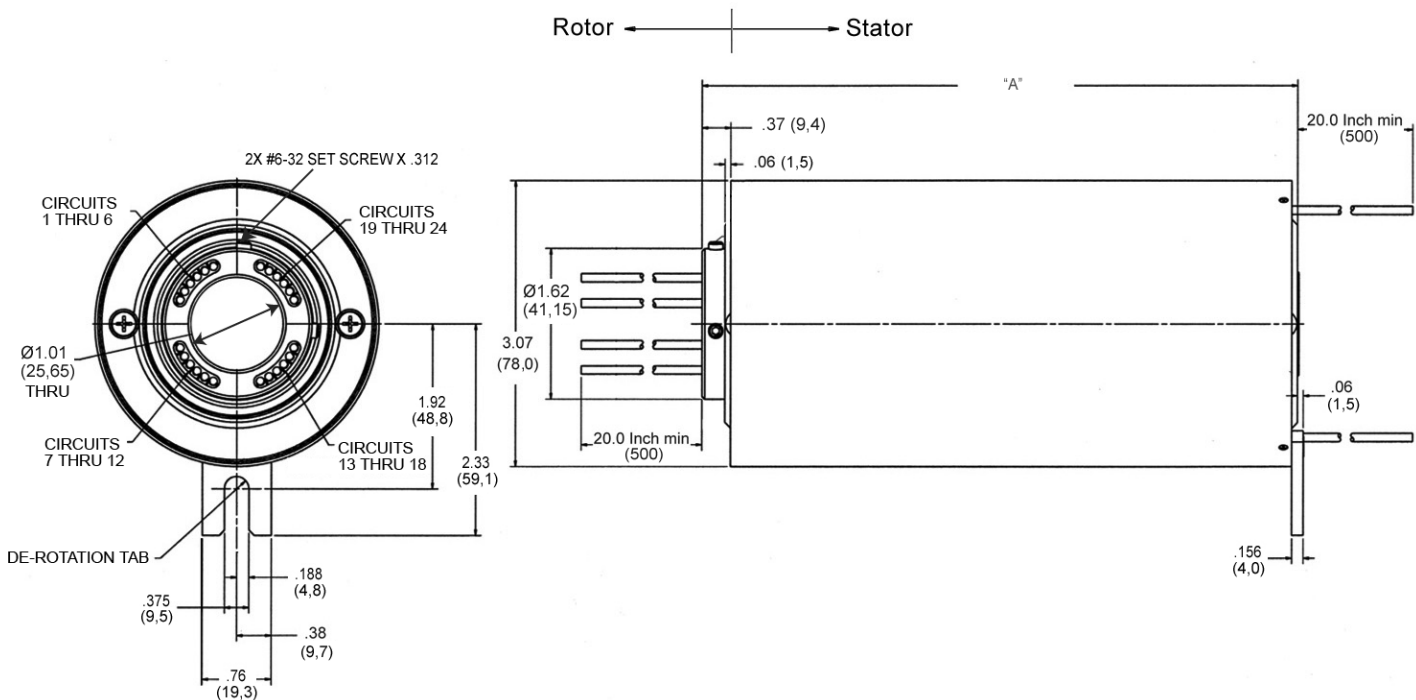

Dimensions in inches (millimeters)

Slip Rings With Through-Bores

AC6875 Specifications (IP 65 Sealed Version of AC6349)		Options
Operating Speed	250 rpm* continuous	<ul style="list-style-type: none"> • Steel bearings • Gold - plated rings • Seals • Long leads
Number of Circuits	6, 12, 18, or 24	
Lead Length	20 inch standard	
Lead Size / Type	14 gauge, white with tags	
Voltage	440 VAC	
Operating Temp.	-40°C to +80°C	
Contact Material	Silver-on-silver	
Current Rating	15 amps / circuits	
Circuit Resistance	200 milliohms with 12 inch leads	
Electrical Noise	60 milliohms max. @ 6 VDC 50 milliamps when running @ 5 rpm	
Environmental	IP 65 sealed	

*Please note that the operational life of the unit is dependent upon rotational speed, environment and temperature.

Part Number	Length "A"
AC6875-6	2.9 inch (73,7 mm)
AC6875-12	4.1 inch (104,1 mm)
AC6875-18	5.3 inch (149,7 mm)
AC6875-24	6.5 inch (165,1 mm)

Standard units are not sealed.

AC6875 Dimensions

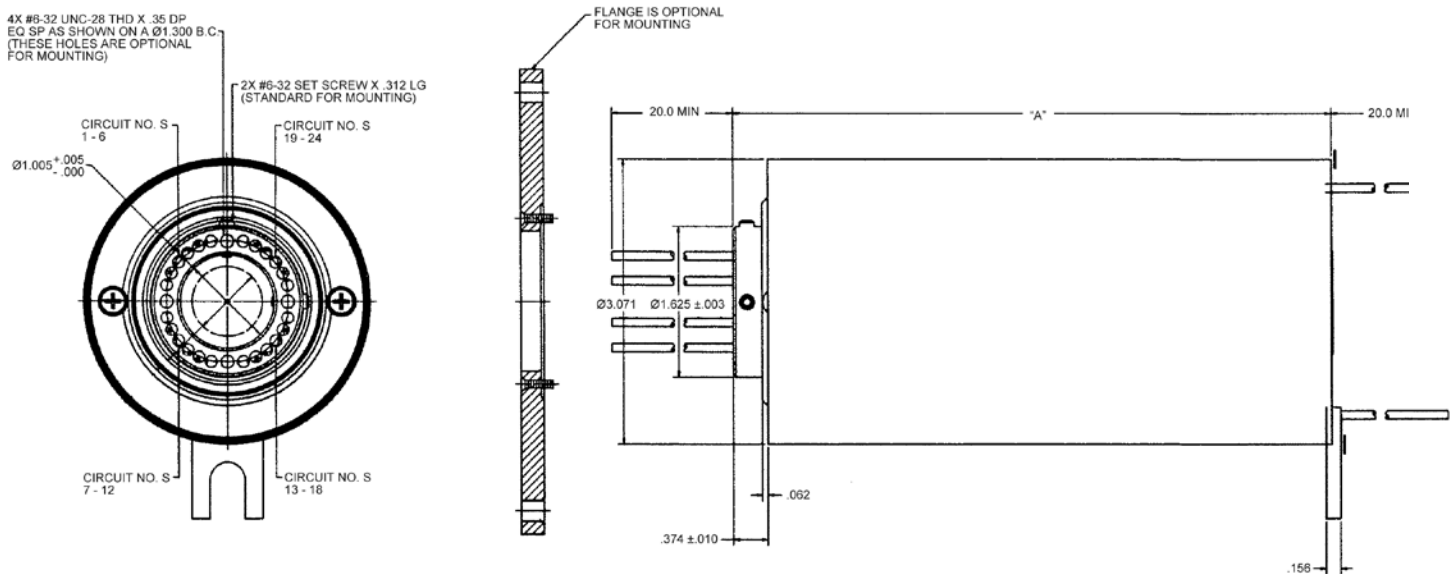

Dimensions in inches