



**APPLICATION NOTE:  
INTEGRATING SERIES C&D MOTORS  
WITH  
ALLEN-BRADLEY ULTRA 5000 DRIVES**

Moog Models: 4020\_C, 4020\_D, 5020\_C & 5020\_D  
Allen-Bradley Models: 2098-IPD-030, 2098-IPD-075

AN-0128 Rev C  
Date: August 6, 2009

**Model Numbers with LCB Option**

40202C 40204C 40206C  
40202D 40204D 40206D  
50202C 50204C 50206C  
50202D 50204D 50206D

---

Moog Components Group  
Springfield Operations  
750 West Sproul Road  
Springfield, PA 19064  
Ph: 610-328-4000, Toll Free: 800-510-6855  
Fx: 610-605-6216      ©2009  
E-mail: [mcg@moog.com](mailto:mcg@moog.com) Web-site: [www.moog.com/components](http://www.moog.com/components)

PAGE INTENTIONALLY LEFT BLANK

## Table of Contents:

<b>1. SAFETY:</b> .....	<b>5</b>
<b>2. WARNINGS, CAUTIONS AND NOTES:</b> .....	<b>5</b>
<b>3. SCOPE:</b> .....	<b>7</b>
<b>4. EQUIPMENT AND INTERCONNECTIONS:</b> .....	<b>8</b>
4.1. Running Ultraware with a Host Computer: .....	9
4.1.1. Host Computer Requirements: .....	9
4.1.2. Installing Ultraware: .....	9
4.1.3. Ultraware Users Manual: .....	9
4.2. Moog Integration Packages.....	10
4.2.1. Standard Response “C” Series System (IP-1C) Components .....	10
4.2.1.1. Standard Response “C” Series Interconnection (IP-1C) .....	11
4.2.1.2. “C” Series System AC Power (IP-1C) .....	12
4.2.2. High Response “D” Series System (IP-1D) Components:.....	12
4.2.2.1. High Response “D” Series Interconnection (IP-1D):.....	13
4.2.2.2. “D” Series System AC Power (IP-1D).....	14
4.2.3. Temperature Switch Connections (Digital I/O) .....	14
4.2.4. Power Cable Shield Termination .....	15
4.2.5. Communication Address Switch Settings .....	16
4.2.6. Position Sensor (Feedback) Connection.....	16
4.2.7. Motor Drive Connection .....	16
<b>5. CREATING BASIC MOTION WITH THE SYSTEM:</b> .....	<b>17</b>
5.1. Installing Moog Motor Parameters into Ultra 5000 Drive: .....	17
5.1.1. Downloading Moog Data Disk:.....	17
5.1.2. Motor Database Window: .....	17
5.1.3. Importing Moog Motor Parameters: .....	18
5.1.4. Inserting Moog Motor Parameters:.....	18
5.2. Setting Initial Tuning Values: .....	20
5.3. Run a Motion Program:.....	20
5.3.1. Loading Program into Workspace:.....	20
5.3.2. Moving the Executable Program into the Drive:.....	21
5.4. Running the Motion Program:.....	21
<b>6. MODIFYING THE MOTION PROGRAM:</b> .....	<b>22</b>
6.1. Editing Source Code.....	22
6.2. Compiling the Program .....	22
6.3. Loading the Compiled Program .....	22
6.4. Running New Program.....	22
<b>7. TUNING SYSTEM:</b> .....	<b>23</b>
<b>APPENDIX-A: (REVISION HISTORY).....</b>	<b>24</b>

**APPENDIX-B: (SAMPLE PROGRAM “Moog-DEMO” ) ..... 25**

AN-0128

3 of 26

Revision C

PAGE INTENTIONALLY LEFT BLANK

## 1 **Safety:**

The Moog motor is capable of producing high forces and velocities. Always follow appropriate safety precautions when installing and applying these motors. Equipment should be designed and utilized to prevent personnel from coming in contact with moving parts and electrical contacts that could potentially cause injury. Read all cautions, warnings and notes before attempting to operate these devices. Follow all applicable codes and standards when utilizing this equipment.

## 2 **Warnings, Cautions and Notes:**

The following conventions are used on the equipment and found in this manual. Please read all equipment labels and manuals before attempting to use Moog Linear Motors.



**WARNING:** Identifies information about practices or circumstances that can lead to personal injury, property damage, or loss of life if not correctly followed.

A **WARNING** identifies information that is critical for identifying and avoiding a hazard that could lead to serious personnel injury or equipment damage.



**CAUTION:** Identifies information about practices or circumstances that can lead to severe equipment damage.

A **CAUTION** identifies information that is critical to prevent permanent equipment damage.

**NOTE:** Identifies information that is critical for successful application and understanding of the product.

A **NOTE** identifies information that is critical for successful application and understanding of the product.

The following is a list of warnings and cautions that must be observed when working with Moog High Force Linear Motors.



**WARNING:** This equipment contains **HIGH ENERGY PERMANENT MAGNETS.** Do not attempt to disassemble. Serious damage to property or injury to person may result. Keep ferrous materials away from the motor.



**WARNING:** Improper Servo tuning can cause uncontrolled motion of the Moog motor. Do not allow the system to oscillate during the tuning process, and keep all persons and body parts away from moving parts.



**WARNING:** Do not use drives powered by voltages greater than 240 VAC.



**WARNING:** Keep fingers and limbs clear of the motor and moving parts when power is applied to the motor.



**WARNING:** This system produces very high forces and rapid motion. Under no circumstances should it be operated when hands, fingers or clothing are in, on, or near the motor. Guards should be installed to prevent such items from coming into contact with the motor or other moving parts.



**CAUTION:** Only use Anderol 465. Other lubricants could break down prematurely and cause permanent damage to the motor and contaminate the bearings.

### 3 Scope:

This manual contains the basic information needed to use Moog C&D series motors with Allen-Bradley Ultra 5000 Intelligent Positioning Drives to run basic motion programs. The basic servo systems are outlined in this manual: The standard response C series system is for applications with large masses or not requiring high precision. The high response D series system is for applications that require tight precision control and high accelerations.

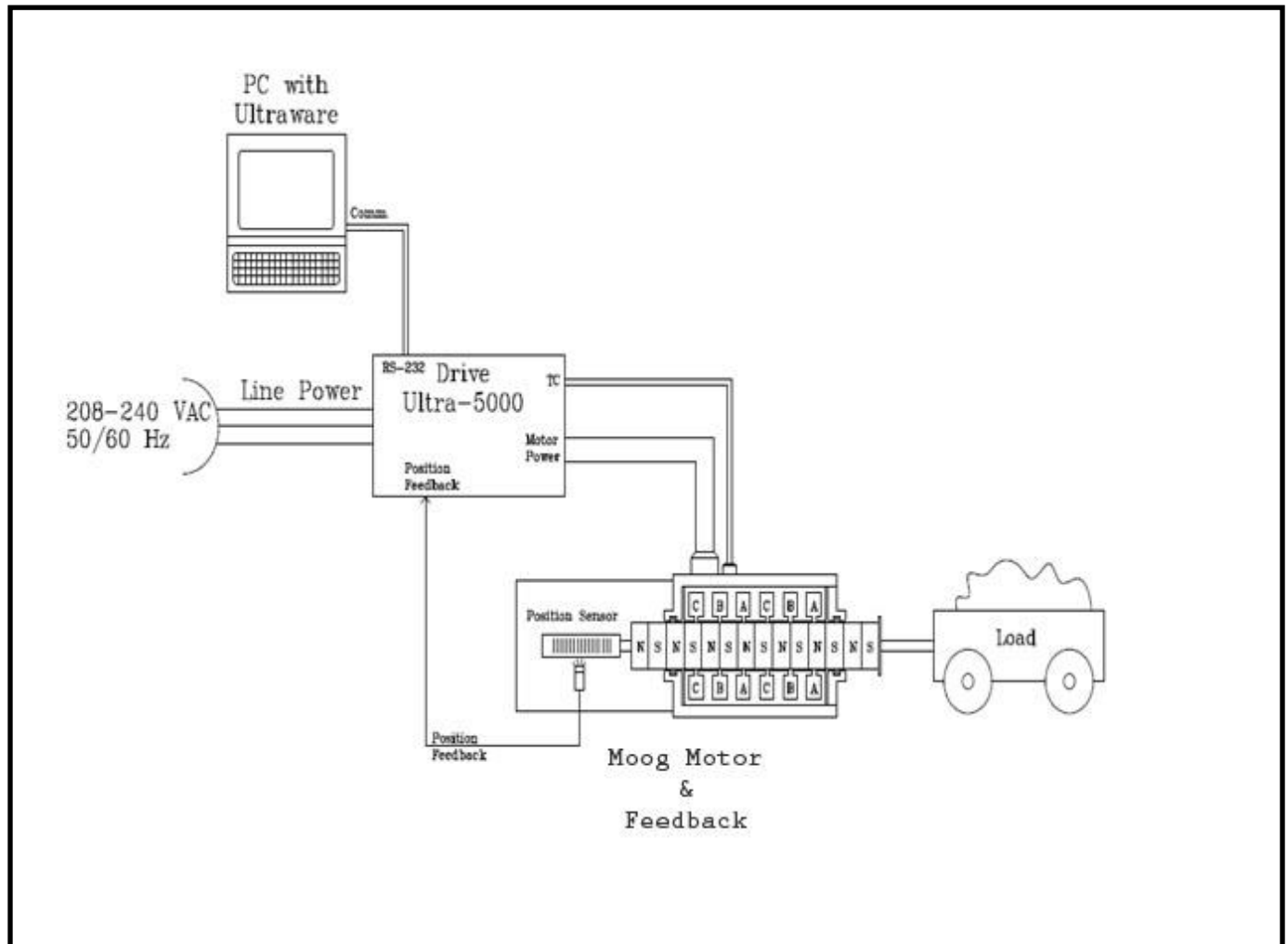

**Fig 3-1**  
**Basic System with Ultra 5000**

### 4 Equipment and Interconnections:

The section describes the equipment and interconnections in the Standard Response C Series or High Response D Series systems.

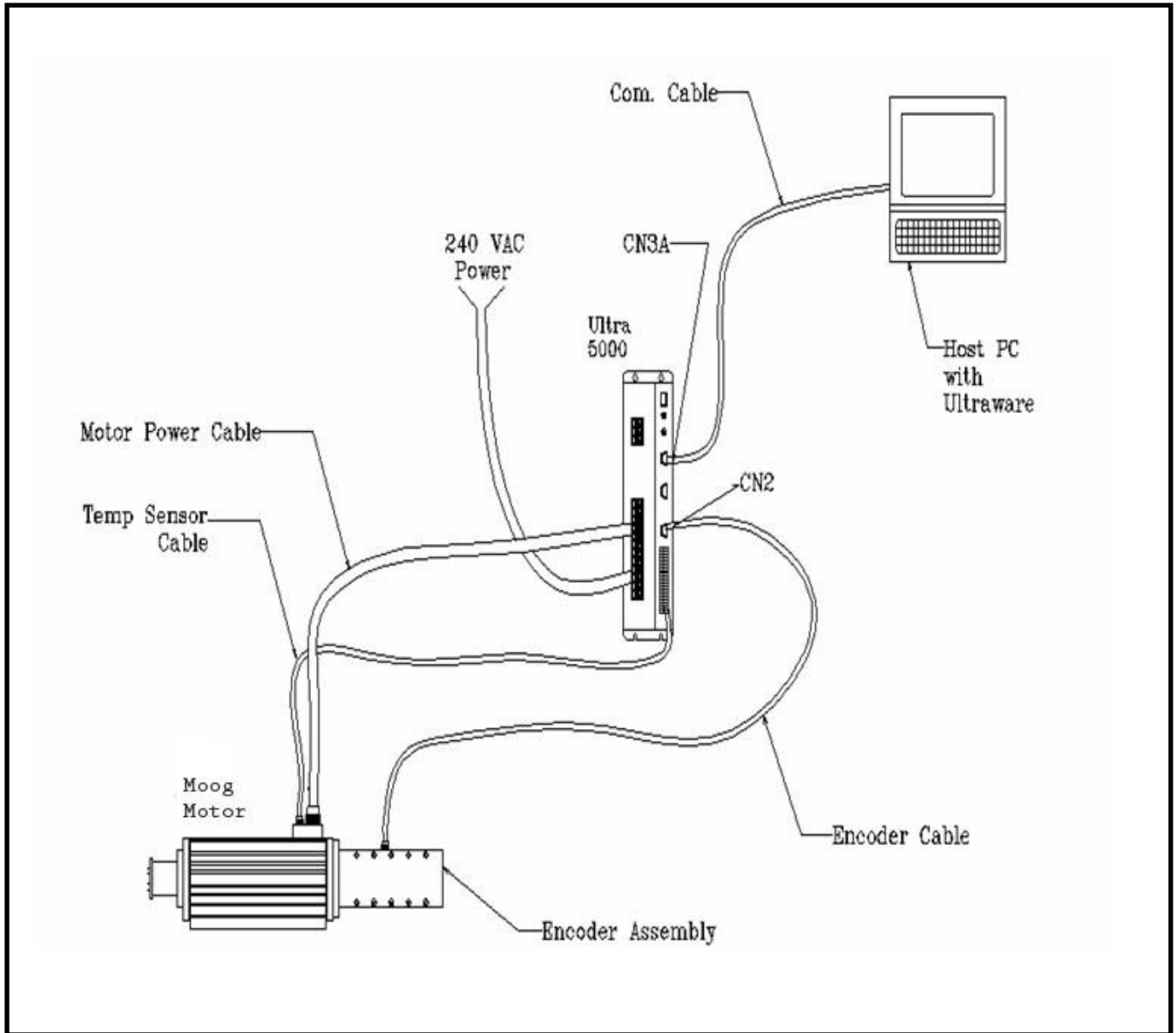

**Fig 4-1**  
**Moog Integration Packages IP-1C and IP-1D**

## **4.1 Running Ultraware with a Host Computer:**

The Ultra 5000 system requires a Host PC loaded with Allen-Bradley Ultraware version 1.5 or later and the null modem communication cable (CC-01-10) included with the IP-1C and IP-1D packages.

### **4.1.1 Host Computer Requirements:**

The host computer requirements are defined in Allen-Bradley Publication 2098-IN002A-EN-P. (Provided with Ultraware)

System Requirements: <http://www.ab.com/manuals/gmc/2098-IN002A-EN-P-JUN00.pdf>

### **4.1.2 Installing Ultraware:**

Installing Ultraware is very similar to installing most standard software. Follow the Allen-Bradley installation instructions contained in Allen-Bradley Publication 2098-IN002A-EN-P (Provided with Ultraware). Be sure to install a “typical” setup type not “compact”.

Instructions: <http://www.ab.com/manuals/gmc/2098-IN002A-EN-PJUN00.pdf>

### **4.1.3 Ultraware Users Manual:**

Ultraware is extensive user interface software for use with Allen-Bradley Ultra 3000 and 5000 series drives. Moog recommends reviewing the Ultraware Users Manual 2098-UM001D-EN-P before running a Moog motor with an Ultra series drive.

Users Manual: <http://www.ab.com/manuals/gmc/2098-UM001D-EN-P-AUG01.pdf>

The Moog Integration Packages IP-1C and IP-1D are all-inclusive packages consisting of an Allen Bradley Ultra 5000 Drive, Interconnection Cables and Software needed to control a Moog “C” or “D” series Linear Motor with the LCB encoder option.

Before connecting the system components, read Moog Users Manual, Feedback Sensor Manual, and Allen-Bradley Ultra 5000 Installation Manual:

Installation Manual: <http://www.ab.com/manuals/gmc/2098-IN001E-EN-P-APR02.pdf>

#### **4.2.1 Standard Response “C” Series System (IP-1C) Components**

<u>Component</u>	<u>Part Number</u>
1. Motor (one of):	50202CxxT-LCB-CV 50204CxxT-LCB-CV 50206CxxT-LCB-CV 40202CxxT-LCB-CV 40204CxxT-LCB-CV 40206CxxT-LCB-CV
2. Integration Package 1C:	IP-1C Consisting of:
a. Motor Drive:	MD-1001-030 (AB P/N: 2098-IPD-030)
b. Motor Drive Cable:	MPC-30-25-3
c. Feedback Cable:	FSC-LA-25
d. Temp Sensor Cable:	TSC-01-25
e. Communication Cable:	CC-01-10
f. Ultraware Software:	SW-101 (AB P/N: 2098UWCPRG)
g. Moog Data Disk:	DD-101
h. Motor Users Manual:	UM-102
i. Linear Encoder Users Manual:	UM-103
j. Application Note:	AN-0128
3. Host Computer: As Defined in Section 4.1.1	

Inter connect the Standard Response system per Figure 4.2. Do not connect AC power until all other connections have been made. When AC power is applied, it should be connected per Allen-Bradley Ultra 5000 instructions following all warnings and cautions in accordance with relevant electrical codes.

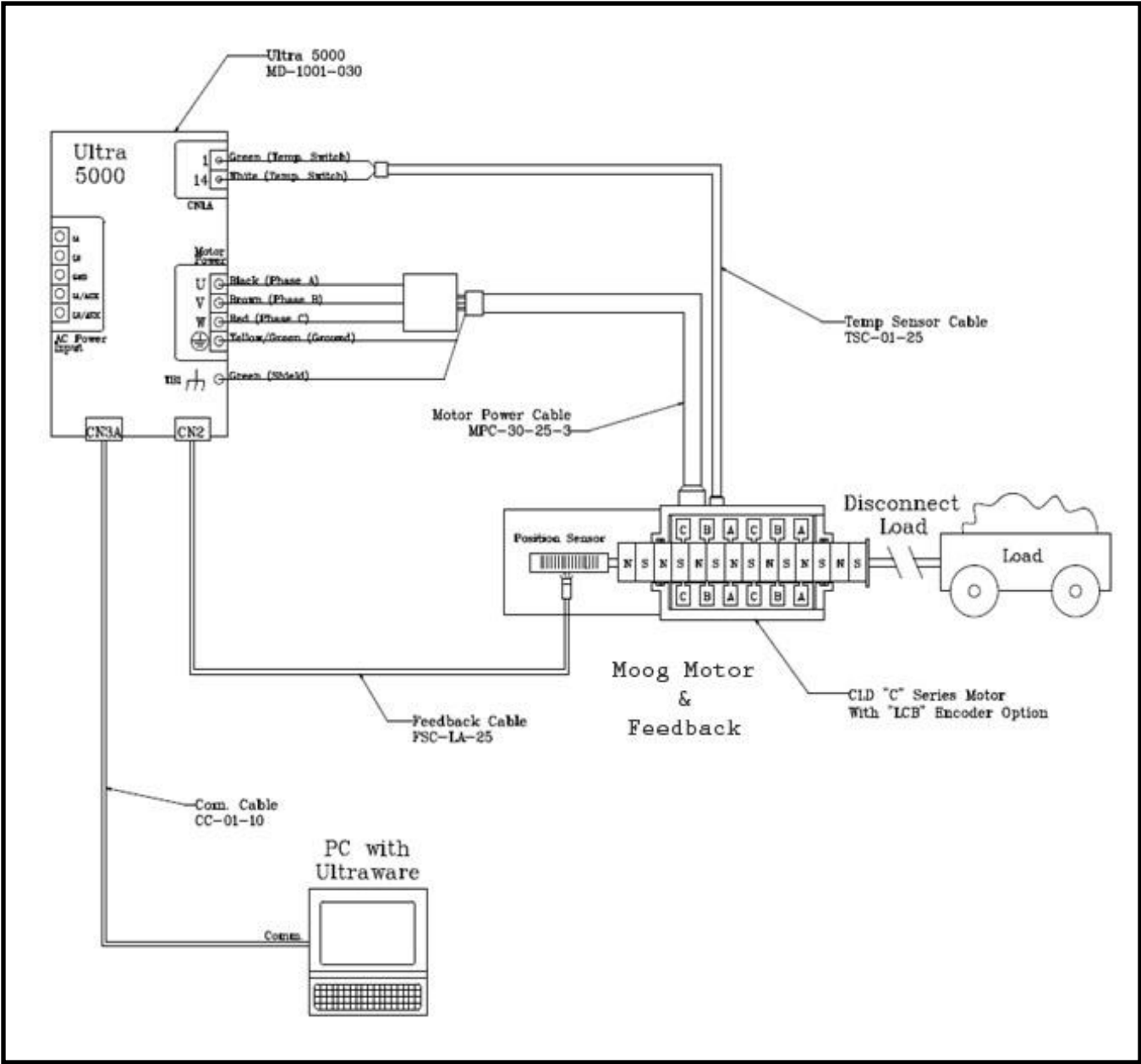

**Fig. 4.2.1.1**  
**Interconnection of Standard Response "C" Series System**

### 4.2.1.2 **“C” Series System AC Power (IP-1C)**

AC Power is single phase 208-240 Vac 50/60 Hz that is applied to L1 and L2. AC Power should be applied using all the cautions and safety typical of any equipment with this level of power. Ensure the system is well grounded before applying power. The Allen-Bradley Ultra 5000 Installation Manual (2098-IN001E-EN-P) contains detailed information on interconnection of the drive and should be referenced. Ensure all relevant electrical codes and standards are followed in accordance with national and local laws.

Installation Manual: <http://www.ab.com/manuals/gmc/2098-IN001E-EN-P-APR02.pdf>

### 4.2.2 **High Response “D” Series System (IP-1D) Components:**

<u>Component</u>	<u>Part Number</u>
1. Motor (one of):	50202DxxT-LCB-CV 50204DxxT-LCB-CV 50206DxxT-LCB-CV 40202DxxT-LCB-CV 40204DxxT-LCB-CV 40206DxxT-LCB-CV
2. Integration Package 1C:	IP-1D Consisting of:
a. Motor Drive:	MD-1001-075 (AB P/N: 2098-IPD-075)
b. Motor Drive Cable:	MPC-60-25-3
c. Feedback Cable:	FSC-LA-25
d. Temp Sensor Cable:	TSC-01-25
e. Communication Cable:	CC-01-10
f. Ultraware Software:	SW-101 (2098UWCPRG)
g. Moog Data Disk:	DD-101
h. Motor Users Manual:	UM-102
i. Linear Encoder Users Manual:	UM-103
j. Application Note:	AN-0128
3. Host Computer:	As Defined in Section 4.1.1

### 4.2.2.1 High Response “D” Series Interconnection (IP-1D):

Inter connect the Standard Response system per the diagram below. Do not connect AC power until all other connections have been made. When AC power is applied, it should be connected per Allen-Bradley Ultra 5000 instructions following all warnings, and cautions in accordance with all relevant electrical codes.

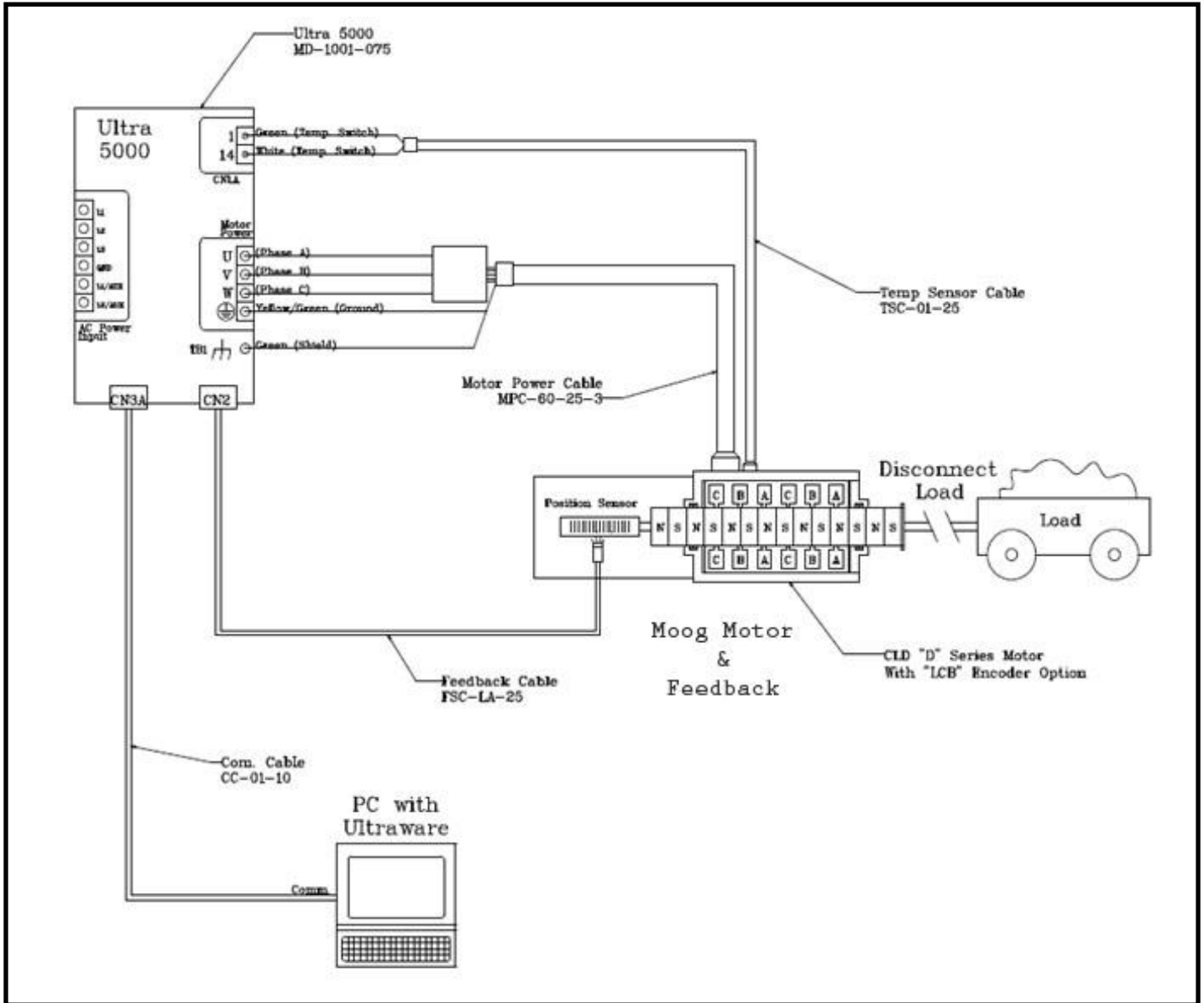

**Figure 4.2.2.1**  
**Interconnection of Standard Response “D” Series System**

### 4.2.2.2 **“D” Series System AC Power (IP-1D)**

AC Power is three phase 208-240 Vac 50/60 Hz that is applied to L1, L2 and L3. AC Power should be applied observing all the cautions and safety typical of any equipment with this level of power. Ensure the system is well grounded before applying power. The Allen-Bradley Ultra 5000 Installation Manual (2098-IN001E-EN-P) contains detailed information on interconnection of the drive and should be referenced. Ensure all relevant electrical codes and standards are followed in accordance national and local laws.

Installation Manual: <http://www.ab.com/manuals/gmc/2098-IN001E-EN-P-APR02.pdf>

### 4.2.3 **Temperature Switch Connections (Digital I/O)**

Configure the Allen Bradley Ultra 5000 drive to utilize the internal 24 V power supply by following the directions in chapter 3 of the “Ultra 5000 Intelligent Positioning Drives Installation Manual”. This manual is provided with the drive.

Installation Manual: <http://www.ab.com/manuals/gmc/2098-IN001E-EN-P-APR02.pdf>

In summary:

Connect the temperature Switches per Figure 4.2.2 and 4.2.2.1.

Wire I/O Connections to wire CN1 sockets 1 and 28.

1. Prepare your I/O wires by stripping approximately 6 mm (0.25 in.) of insulation from the end.

**NOTE:** Use caution not to nick, cut, or otherwise damage strands as you remove the insulation.

2. Using the small blade type screw driver supplied with your Ultra5000 (part number 9111-0031) depress the spring clamp next to the pin you're prepared to wire and insert the wire, as shown in Figure 4.2.2.1.
3. Remove the screwdriver and gently pull on the wire to make sure it does not come out of its terminal. Re-insert and test any loose wires.

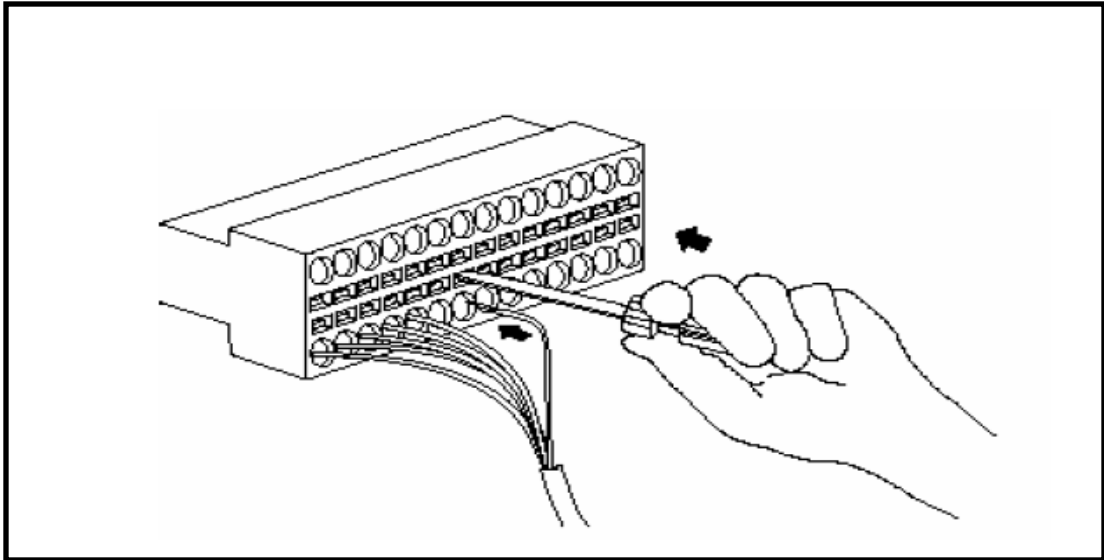
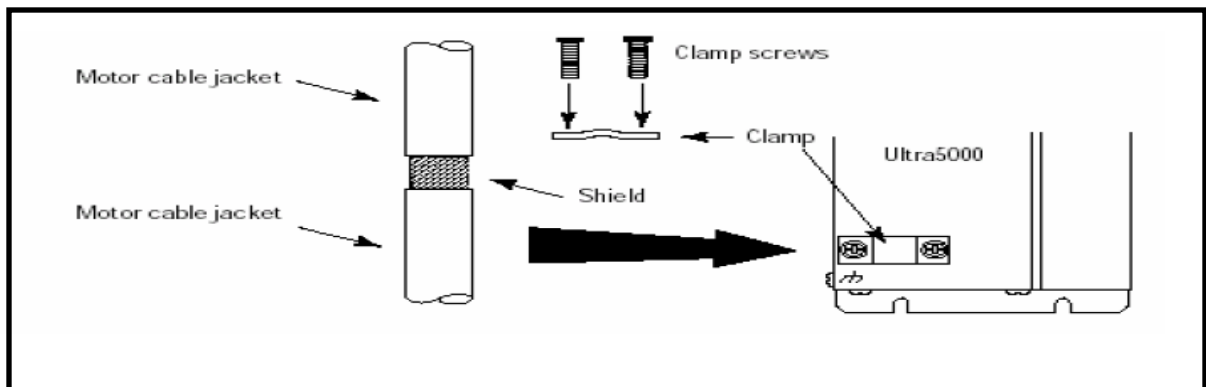

**Figure 4.2.3**  
**Inserting Wires into the Connector Housing**

#### 4.2.4 Power Cable Shield Termination

Factory supplied motor power cables are shielded, and the power cable is designed to be terminated at the drive during installation. A small portion of the cable jacket is removed which exposes the shield braid. The exposed area must be clamped to the front of the drive chassis (refer to Figure 4.2.2.2) using the clamp provided. in chapter 3 of the “Ultra 5000 Intelligent Positioning Drives Installation Manual”. This manual is provided with the drive.

Installation Manual: <http://www.ab.com/manuals/gmc/2098-IN001E-EN-P-APR02.pdf>

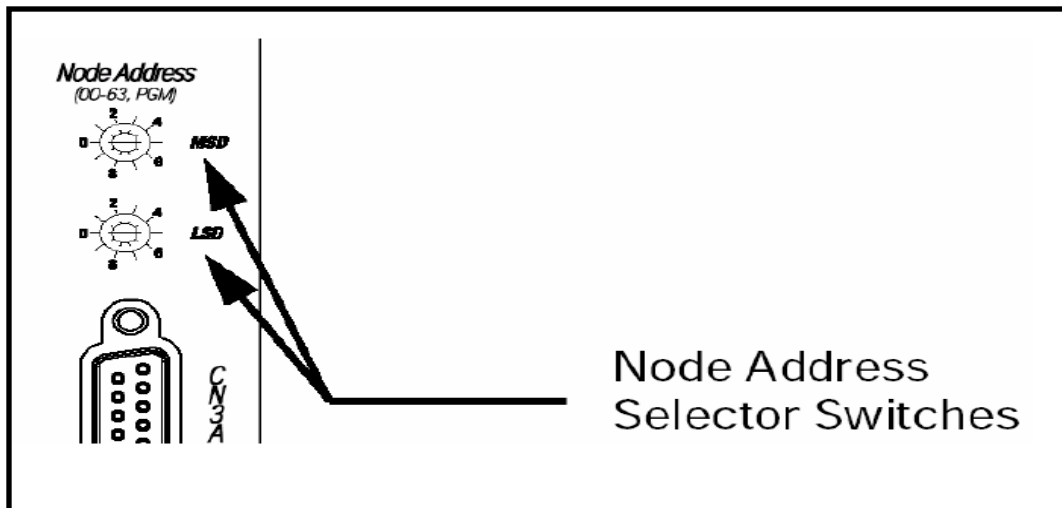

**Figure 4.2.2.2**  
**Motor Power Cable Shield Termination**

## 4.2.5 Communication Address Switch Settings

The Ultra5000 communication address selector switches (MSD and LSD) allow setting a unique address (0-99) for each Ultra5000 connected on a serial network. Refer to Figure 4.2.2.3 for the switch locations. Set MSD to 0 and LSD to 1. For more information on the use of the Communication Address Settings refer to chapter 4 of the “Ultra 5000 Intelligent Positioning Drives Installation Manual”. This manual is provided with the drive

Installation Manual: <http://www.ab.com/manuals/gmc/2098-IN001E-EN-P-APR02.pdf>



**Figure 4.2.2.3**  
**Communications Switch Settings**

## 4.2.6 Position Sensor (Feedback) Connection

Connect the circular connector of the FSC cable to the motor feedback. Connect the HDB15 connector of the FSC cable to the CN2 connector on the Ultra 5000 drive.

## 4.2.7 Motor Drive Connection

Connect the circular connector of the MPC cable to the motor power connector. Connect the pigtail leads of the MPC cable to the Ultra 5000 drive as shown in Figure 4.2.1.1 or Figure 4.2.2.2.

## **5 Creating Basic Motion with the System:**

After the system has been connected per section 4 and all the relevant instructions followed in the Allen-Bradley Ultra 5000 Installation Manual 2098-IN001x-EN-P the system is ready to begin motion. At this point the Moog motor should not be connected to any load and the shaft should be fully retracted. Before applying power ensure that no damage or injury will occur if the shaft moves rapidly to full extension.

Installation Manual: <http://www.ab.com/manuals/gmc/2098-IN001E-EN-P-APR02.pdf>

### **5.1 Installing Moog Motor Parameters into Ultra 5000 Drive:**

The Moog motor parameters need to be loaded in the Ultra 5000 drive. This is accomplished through the following steps:

#### **5.1.1 Downloading Moog Data Disk:**

Download the Moog data disk, DD-101, to your hard disk as follows:

1. Insert the data disk, DD-101 into your CD drive.
2. Use your Windows system to copy the *AB Motor Files* and *AB Programs* directories to your hard disk. A convenient location for installing these is the directory that contains Ultraware and its associated files. By default this directory is:

*C:\ProgramFiles\Rockwell Automation\Ultraware.*

#### **5.1.2 Motor Database Window:**

The Motor Database is accessed by:

1. Clicking on the Windows **Start** button.
2. Selecting Programs, Ultraware, and Motor Configuration to display the Open Motor Data window, and Opening the file *Motors.mdb* from the Ultraware directory to display the Motor Database window.

### 5.1.3 Importing Moog Motor Parameters:

Use the following steps to insert the Moog motor parameters into the Allen-Bradley Motor Database file:

1. Insert the Moog Data Disk (DD-101) into the computer's CD drive.
2. Click on **File** in the Main Menu bar of the Motor Configuration Program.
3. Select **Import** on the dropdown menu.
4. Using the import file window select the file location to which you copied the Moog data disk directories. Select the *AB Motor Files* directory and double click the Motor Exchange File (.mxf) that represents your motor part number.

**Example:** (C:\Program Files\Rockwell Automation\Ultraware\AB Motor Files\MOOG5020XXT-LCB-CV.mxf)

5. Scroll down list of motors to ensure that motor Part Number has been inserted.
6. Exit the Motor Database window.

### 5.1.4 Inserting Moog Motor Parameters:

Power up the drive and Establish communications between the host computer and the Allen-Bradley drive in accordance with Allen-Bradley Ultraware Users Manual 2098-UM001D-EN-P. Communicating with drive is described in Chapter 1 of the Ultraware Users Manual.

Communication is established when the icon 5K Ultra Drive under Online Drives is present in the work space of the Ultraware.

Users Manual: <http://www.ab.com/manuals/gmc/2098-UM001D-EN-P-AUG01.pdf>

The following load the appropriate Moog motor into the Ultra 5000 drive:

1. Click on the Windows **Start** button
2. Select **Programs, Ultraware, and Ultraware** to begin the Ultraware software.

2. Select **Create new file** then .
4. The system will start searching for connected drives. Select  once drive 1 has been detected.
5. Expand the Ultra 5000 tree in the Ultraware by selecting .
6. Double click the  icon on the tree to open the motor parameter window.
7. Click on **Auto Motor Iden** scroll bar and select .
8. Click on **Motor Model** scroll bar and select the appropriate Moog motor model from the list . Ensure that the listed motor parameters change.
9. Change the **Total Moving Mass** to that listed in the table below:

<b>Motors</b>	<b>Mass (kg)</b>					
	<b>2"</b>	<b>4"</b>	<b>6"</b>	<b>8"</b>	<b>10"</b>	<b>12"</b>
40202.../50202...	3.6	4.2	4.8	5.5	6.1	6.8
40204.../50204...	4.8	5.5	6.1	6.8	7.4	8.1
40206.../50206...	6.1	6.8	7.4	8.1	8.8	9.5

**NOTE:** When the load is attached the shaft moving mass will need to be changed to the total mass of the shaft plus load.

## 5.2 Setting Initial Tuning Values:

Basic tuning parameters need to be set in the Ultra 5000 drive to for basic motion to occur. The Moog motor parameters need to be loaded into the Ultra 5000 drive.

This is accomplished through the following steps:

1. Open the  window by clicking on the Tuning icon under Ultra 5K.
2. Expand the Velocity Regulator Gains by clicking on the . Then set the values listed in Table 5.1.
3. Expand the Position Regulator Gains by clicking on the . Then set the values listed in Table 5.2.

Do not attempt to use the Autotuning function in the Ultraware. Large rapid motions may occur and cause damage to the motor or drive.

**Table 5.1**

P	380
I	0
FF	1
Bandwidth	0
Upper Limit	30
Lower Limit	-30

**Table 5.2**

Kp	400
Kpz	0
Kpz zone	0
Ki	0
Ki zone	0
Kff	5

## 5.3 Run a Motion Program:

Load an existing motion program from the Moog Data Disk DD-101 with the following sequence:

### 5.3.1 Loading Program into Workspace:

The following steps will load a Moog-Demo program into the Ultraware workspace.

1. In the Main Menu bar of Ultraware click on **File**.
2. Select **Open** and select the file location to which you copied the Moog data disk directories. Select the *AB Programs* directory and then double click on *MOOG-Demo Rev A.udb*.

**Example:** (C:\Program Files\Rockwell Automation\Ultraware\AB Programs\MOOG-Demo Rev A.udb)

3. In the Workspace the Moog-Demo program will appear offline.

- Using the import file window select the file location to which you copied the Moog data disk directories. Select the AB Motor Files directory and choose the Motor Exchange File (.mxf) that represents your motor part number.

*Example:* (C:\Program Files\Rockwell Automation\Ultraware\AB Motor Files\MOOG5020XXT-LCB-CV.mxf)

### **5.3.2 Moving the Executable Program into the Drive:**

Executable programs are moved from the offline drive to the online drive:

Expand Moog-Demo by clicking on .

MOOG-Demo.EXE will appear under the Moog-Demo directory.

Drag and drop the MOOG-Demo.EXE into the drive's "Programs" directory.

The program will automatically load into the drive.

Expand Programs by clicking on .

Ensure that MOOG-Demo.EXE appears under the Programs directory.

### **5.4 Running the Motion Program:**

The Moog-Demo program loaded into the drive extends the shaft .5" inches, then extends and retracts the shaft 1.0" ten times and, then retracts into the initial position. To run the program:

- Manually push the motor shaft fully into the motor.**
- In the Ultraware Workspace under the icons **Online Drive, Programs** highlight icon **Moog-Demo**.
- Start the program by highlighting MOOG-Demo.EXE in the "Programs" directory and then selecting  on the main toolbar. The program can also be run by selecting **Program, Run** on the main menu.
- The motor should extend, cycle, and return.

## 6 Modifying the Motion Program:

This section modifies the Moog-Demo program to change the number of cycles from 10 to 100.

### 6.1 Editing Source Code

The basic steps in editing the source code are as follows:

1. Open the source code by double clicking on Moog-Demo.c in the workspace under the offline drive.
2. Scroll to Line 32 and change the variable **max** from 10 to 100.

<b>Original:</b>	Line 32:	“max=10; /* The number of cycles*/”
<b>Modified:</b>	Line 32:	“max=100; /* The number of cycles*/”

### 6.2 Compiling the Program

Compile the modified Moog-Demo.c program by right clicking on the “C” program in the workspace. Select Build on the drop down and the program will be compiled. A message should appear stating that the program has been successfully compiled.

### 6.3 Loading the Compiled Program

Move the newly compiled program to the online drive:

1. Drag and drop the MOOG-Demo.EXE into the drive’s “Programs” directory.
2. The Program will automatically load into the drive.
3. Expand Programs by clicking on .

Ensure that Moog-Demo appears under the Programs directory

### 6.4 Running New Program

The new Moog-Demo program loaded into the drive extends the shaft .5” inches, then extends and retracts the shaft 1.0” one hundred times and retracts to it initial position. To run the program:

1. Manually push the motor shaft fully into the motor.
2. In the Ultraware Workspace under the directory **Online Drive, Programs** highlight the icon **Moog-Demo**.
3. Start the program by selecting from the Main Menubar Program, **Run**.

4. The motor should extend, cycle, and return.

## 7 **Tuning System:**

The tuning parameters entered in Section 5.3 are basic parameters used to create motion that is not necessarily precise. The system should be tuned in accordance with the Allen-Bradley instructions. Do not expect the system to have precise motion with the initial tuning parameters.



**WARNING: Improper Servo tuning can cause uncontrolled motion of the Moog motor. Do not allow the system to oscillate during the tuning process, and keep all personnel and body parts away from moving equipment.**

## **Appendix-A: (Revision History)**

*ECO # Revision Change Date \_*

0111 A Initial Release March 28, 2003

0116 B Revision June 6, 2003

C Revision August 6, 2009

## Appendix-B: (Sample Program “Moog-Demo” )

```
/* MOOG-Demo Rev.B This program produces basic shaft motion on Moog motors */
```

```
#include <motion.h> /* Include the motion library functions */
```

```
/* Motion variables */
```

```
#define ACC      762000    /* (counts/sec**2) */  
#define DCC      762000    /* (counts/sec**2) */  
#define VEL      76200     /* (counts/sec**2) */  
#define ACCSFT   254000    /* (counts/sec**2) */  
#define VELSFT   25400     /* (counts/sec) */  
#define CPI      25400     /* (counts/inch) */
```

```
short int count, max;  
float dist;  
float offset;  
float tpdwl;  
float btdwl;  
float upmv;  
float dnmv;  
float cytm;  
float cpm;
```

```
/*-----  
* FUNCTION: main (Beginning of main program)  
*-----*/
```

```
int main()
```

```
{  
    cpm=100.0;          /* Cycle rate in cycles/min */  
    count=0;           /* Counting variable */  
    max=10;            /* The number of cycles */  
    offset=-.5*CPI;    /* Offset distance */  
    dist=1*CPI;        /* Cycle distance */  
    cytm=60/cpm;       /* Cycle period */  
    tpdwl=cytm*.05;    /* Retract dwell percentage */  
    btdwl=cytm*.05;    /* Extend dwell percentage */  
    upmv=cytm*.45;     /* Retract move time percentage */  
    dnmv=cytm*.45;     /* Extend move time percentage */  
  
    InitMotionLibrary(); /* Initialize motion library functions */  
    AxisDefinePos(0);    /* Set initial position as zero */  
    AxisSetUpperCurLimit(15); /* Current limit durring program */  
    AxisSetLowerCurLimit(-15); /* Current limit durring program */  
    AxisEnable();       /* Enable axis */
```

```

/* Lift offset distance and motion variables */
MoveSetAcc(ACCSFT);
MoveSetDec(ACCSFT);
MoveSetVel(VELSFT);

/* Move to lift offset distance */
MoveIncremental(offset);
    while (MoveInProgress()) { /* loop */ }

/* Movement params */

Sleep (200);          /*Delay*/

do                    /* Cycle */
    {
    MoveOpenBuffer(5,1);
    MoveDVT(-dist,0,dnmv);
    MoveDwell(btdwl);
    MoveDVT(dist,0,upmv);
    MoveDwell(tpdwl);
    MoveCloseBuffer();
    MoveStart();
        while (MoveInProgress()) { /* loop */ };
    if(InputGetState(1))
        count=count+1;
    else
        count=max+1;
    }
while(count<=max);

/* Move home and motion variables */

    MoveSetAcc(ACCSFT);
    MoveSetDec(ACCSFT);
    MoveSetVel(VELSFT);
    Sleep (2000);
    MoveIncremental(-offset);
        while (MoveInProgress()) { /* loop */ }
    Sleep (1000);
    AxisDisable();
    return 0; /* end of program (main function) */
}

```