

MOOG

COMPONENTS GROUP

APPLICATION NOTE: INTEGRATING SERIES C&D MOTORS WITH ALLEN-BRADLEY ULTRA 3000i DRIVES

AN-0130 Rev B
Date: August 6, 2009

Model Numbers with LCB Option

40202C 40204C 40206C
40202D 40204D 40206D
50202C 50204C 50206C
50202D 50204D 50206D

Moog Components Group
Springfield Operations
750 West Sproul Road
Springfield, PA 19064
Ph: 610-328-4000, Toll Free: 800-510-6855
Fx: 610-605-6216 ©2009
E-mail: mcg@moog.com Web-site: www.moog.com/components

PAGE INTENTIONALLY LEFT BLANK

Table of Contents:

1. SAFETY:	5
2. WARNINGS, CAUTIONS AND NOTES:	5
3. SCOPE:	7
4. EQUIPMENT AND INTERCONNECTIONS:	8
4.1. Moog Integration Packages.....	9
4.1.1. Standard Response “C” Series System (IP-2C) Components	9
4.1.2. High Response “D” Series System (IP-2D) Components:.....	10
4.2. Running Ultraware with a Host Computer:.....	10
4.2.1. Host Computer Requirements:	10
4.2.2. Installing Ultraware:.....	11
4.2.3. Ultraware Users Manual:.....	11
4.3. Downloading Moog Data Disk:.....	11
4.4. Descriptions of Interconnections:.....	12
4.4.1. Power Cable Shield Termination	14
4.4.2. Position Sensor (Feedback) Connection.....	14
4.4.3. I/O Connections:.....	14
4.4.3.1. Pendant Connection:.....	14
4.4.3.2. 24VDC Power:	15
4.4.3.3. Over Temperature Sense Cable:.....	15
4.4.4. Communication Cable Connection:	15
4.4.5. System AC Power	15
5. CREATING BASIC MOTION WITH THE SYSTEM:	16
5.1. Configuring the Ultra 3000i Drive:	16
5.1.1. Establishing Communication and Installing Drive Configuration:	16
5.1.2. Importing Moog Motor Parameters:	17
5.1.3. Inserting Moog Motor Parameters:.....	17
5.2. Setting Initial Tuning Values:	19
5.3. Running the system:	19
5.3.1. Description of Pendant Switches:.....	20
6. TUNING SYSTEM:	21
APPENDIX-A: (REVISION HISTORY).....	22
APPENDIX-B: (SETUP “Moog-DEMO”)	23

PAGE INTENTIONALLY LEFT BLANK

1 **Safety:**

The Moog motor is capable of producing high forces and velocities. Always follow appropriate safety precautions when installing and applying these motors. Equipment should be designed and utilized to prevent personnel from coming in contact with moving parts and electrical contacts that could potentially cause injury. Read all cautions, warnings and notes before attempting to operate these devices. Follow all applicable codes and standards when utilizing this equipment.

2 **Warnings, Cautions and Notes:**

The following conventions are used on the equipment and found in this manual. Please read all equipment labels and manuals before attempting to use Moog Linear Motors.



WARNING: Identifies information about practices or circumstances that can lead to personal injury, property damage, or loss of life if not correctly followed.

A **WARNING** identifies information that is critical for identifying and avoiding a hazard that could lead to serious personnel injury or equipment damage.



CAUTION: Identifies information about practices or circumstances that can lead to severe equipment damage.

A **CAUTION** identifies information that is critical to prevent permanent equipment damage.

NOTE: Identifies information that is critical for successful application and understanding of the product.

A **NOTE** identifies information that is critical for successful application and understanding of the product.

The following is a list of warnings and cautions that must be observed when working with Moog High Force Linear Motors.



WARNING: This equipment contains **HIGH ENERGY PERMANENT MAGNETS.** Do not attempt to disassemble. Serious damage to property or injury to person may result. Keep ferrous materials away from the motor.



WARNING: Improper Servo tuning can cause uncontrolled motion of the Moog motor. Do not allow the system to oscillate during the tuning process, and keep all persons and body parts away from moving parts.



WARNING: Do not use drives powered by voltages greater than 240 VAC.



WARNING: Keep fingers and limbs clear of the motor and moving parts when power is applied to the motor.



WARNING: This system produces very high forces and rapid motion. Under no circumstances should it be operated when hands, fingers or clothing are in, on, or near the motor. Guards should be installed to prevent such items from coming into contact with the motor or other moving parts.



CAUTION: Only use Anderol 465. Other lubricants could break down prematurely and cause permanent damage to the motor and contaminate the bearings.

3. Scope:

This manual contains the basic information needed to use Moog C&D series motors with Allen-Bradley Ultra 3000i Intelligent Positioning Drives to run basic motion profiles. The basic systems outlined in this manual include: 1) The standard response IP-2C system for applications not requiring high precision, or with large masses. 2) The high response IP-2D system for applications requiring high precision and high accelerations.

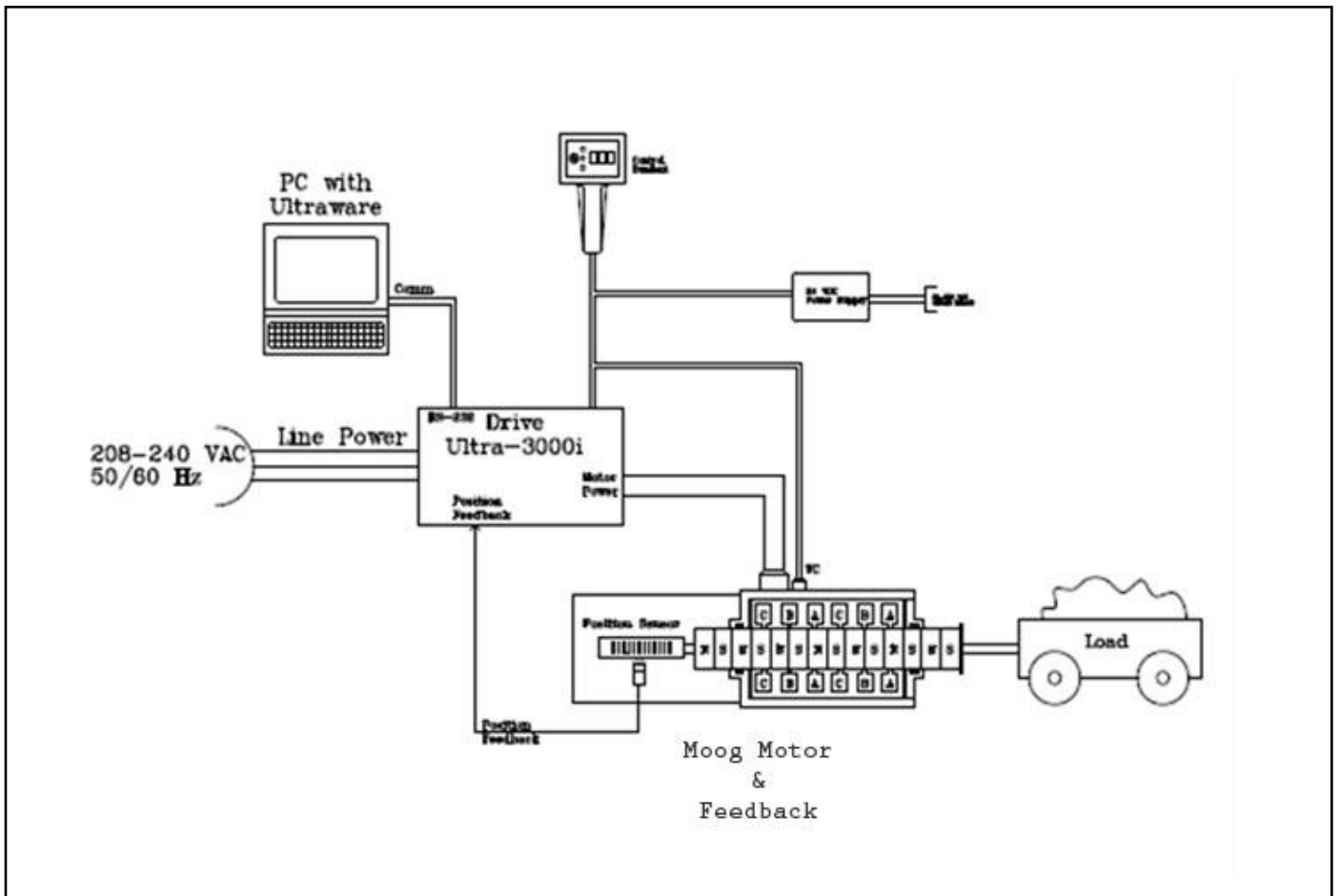

Fig 3-1
Basic System with Ultra 3000i

4. Equipment and Interconnections:

This section describes the equipment and interconnections in the Standard Response C and High Response D Series systems.

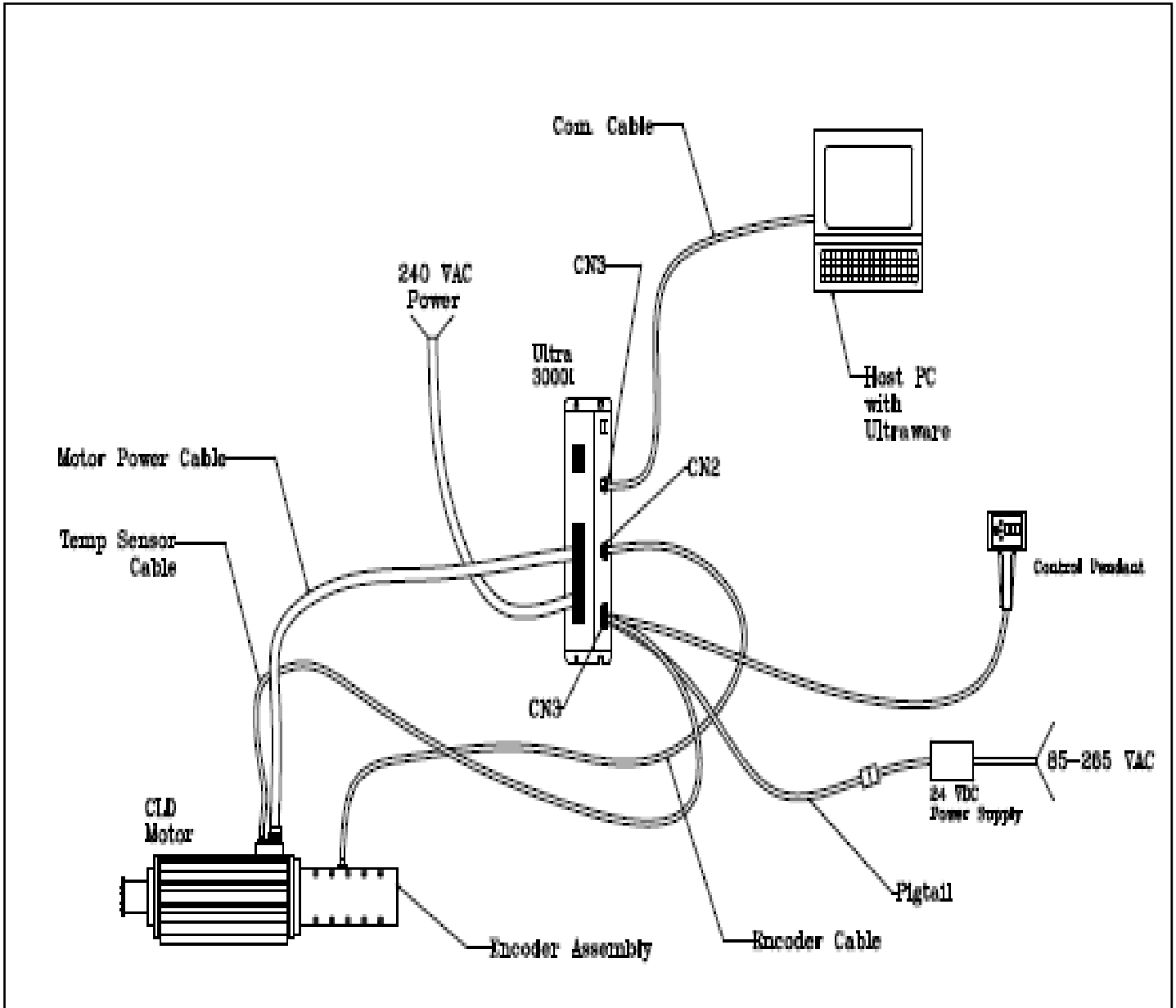

Fig 4-1
Moog Integration Packages IP-2C and IP-2D

4.1. Moog Integration Packages

The Moog Integration Packages IP-2C and IP-2D are all-inclusive packages consisting of an Allen Bradley Ultra 3000i Drive, Interconnection Cables, Control Pendant, 24 VDC Power Supply and Software needed to run a Moog “C” or “D” series Linear Motor with the LCB encoder option.

Before connecting the system components, read the Moog Users Manual, Feedback Sensor Manual, and Allen-Bradley Ultra 3000i Installation Manual all of which are supplied with the system:

Moog Users Manual:

[http://www.calinear.com/support/Users%20Manual%204k%20&%205k%20rev%20A%20Types%20\(C&D\).pdf](http://www.calinear.com/support/Users%20Manual%204k%20&%205k%20rev%20A%20Types%20(C&D).pdf)

Feedback Sensor Manual:

<http://www.calinear.com/support/Users Manual - Linear Encoder Rev A.pdf>

Installation Manual:

<http://www.ab.com/manuals/gmc/2098-IN003C-EN-P-JUL01.pdf>

4.1.1. Standard Response “C” System (IP-2C) Components

<u>Component</u>	<u>Part Number</u>
1. Motor (one of):	50202CxxT-LCB-CV 50204CxxT-LCB-CV 50206CxxT-LCB-CV 40202CxxT-LCB-CV 40204CxxT-LCB-CV 40206CxxT-LCB-CV
2. Integration Package 2C:	IP-2C Consisting of:
a. Motor Drive:	MD-1002-030 (AB P/N: 2098-DSD-030)
b. Motor Drive Cable:	MPC-30-25-3
c. Feedback Cable:	FSC-LA-25
d. Temp Sensor Cable:	TSC-01-25
e. Communication Cable:	CC-01-10
f. Ultraware Software:	2098UWCPRG
g. Moog Data Disk:	DD-101
h. Motor Users Manual:	UM-102
i. Linear Encoder Users Manual:	UM-103
j. Application Note:	AN-0130
k. Control Pendant :	CP-0104-04
l. 24V Power Supply:	PS-001-024
3. Host Computer:	As Defined in Section 4.1.1

4.1.2. High Response “D” System (IP-2D) Components:

<u>Component</u>	<u>Part Number</u>
1. Motor (one of):	50202DxxT-LCB-CV 50204DxxT-LCB-CV 50206DxxT-LCB-CV 40202DxxT-LCB-CV 40204DxxT-LCB-CV 40206DxxT-LCB-CV
2. Integration Package 1C:	IP-2D Consisting of:
a. Motor Drive:	MD-1002-075 (AB P/N: 2098-DSD-075)
b. Motor Drive Cable:	MPC-60-25-3
c. Feedback Cable:	FSC-LA-25
d. Temp Sensor Cable:	SC-01-25
e. Communication Cable:	CC-01-10
f. Ultraware Software:	2098UWCPRG
g. Moog Data Disk:	DD-101
h. Motor Users Manual:	UM-102
i. Linear Encoder Users Manual:	UM-103
j. Application Note:	AN-0128
k. Control Pendant :	CP-0104-04
l. 24V Power Supply:	PS-001-024
3. Host Computer:	As Defined in Section 4.1.1

4.2. Ultraware with a Host Computer:

The Ultra 3000i system requires a Host PC loaded with Allen-Bradley Ultraware version 1.5 or later and the null modem communication cable (CC-01-10) included with the IP-2C and IP-2D packages.

4.2.1. Host Computer Requirements:

The host computer requirements are defined in Allen-Bradley Publication 2098-IN002A-EN-P. (Provided with Ultraware)

System Requirements: <http://www.ab.com/manuals/gmc/2098-IN002A-EN-P-JUN00.pdf>

4.2.2. Installing Ultraware:

Installing Ultraware is very similar to installing most standard software. Follow the Allen-Bradley installation instructions contained in Allen-Bradley Publication 2098-IN002A-EN-P (Provided with Ultraware). Be sure to install a “typical” setup type not “compact”.

Installation Instructions: <http://www.ab.com/manuals/gmc/2098-IN002A-EN-P-JUN00.pdf>

4.2.3. Ultraware Users Manual:

Ultraware is extensive user interface software for use with Allen-Bradley Ultra 3000 and 5000 series drives. Moog recommends reviewing the Ultraware Users Manual 2098-UM001D-EN-P before running a Moog motor with an Ultra series drive.

Users Manual: <http://www.ab.com/manuals/gmc/2098-UM001D-EN-P-AUG01.pdf>

4.3. Downloading Moog Data Disk:

To allow easy access of all the information on the Moog Data Disk Download the Moog data disk, DD-101, to your hard disk as follows:

1. Insert the data disk, DD-101 rev. C or later into your drive.
2. Use your Windows system to copy the *AB Motor Files* and *Ultra 3000i Configurations* directories to your hard disk. A convenient location for installing these is the directory that contains Ultraware and its associated files.
By default this directory is: *C:\Program Files\RockwellAutomation\Ultraware.*

4.4. Descriptions of Interconnections:

Interconnect the system per Figure 4.3. Make connections in the following order and refer to descriptions in the listed sections. Do not connect AC power until all connections have been completed and verified.

Interconnections:

- | | | |
|--------------------------------|----------------|-----------------|
| 1. Motor Power Cable | MPC-30/60-25-3 | Section 4.4.1 |
| 2. Motor Position Sensor Cable | FSC-LA-25 | Section 4.4.2 |
| 3. I/O Connections | | Section 4.4.3 |
| a. Pendant Connection | CA-0104-04 | Section 4.4.3.1 |
| b. 24V Power Supply | PS-001-024 | Section 4.4.3.2 |
| c. Over Temp. Sense Cable | TSC-01-25 | Section 4.4.3.3 |
| 4. Communication Cable | CC-01-10 | Section 4.4.4 |
| 5. System Power | | Section 4.4.5 |

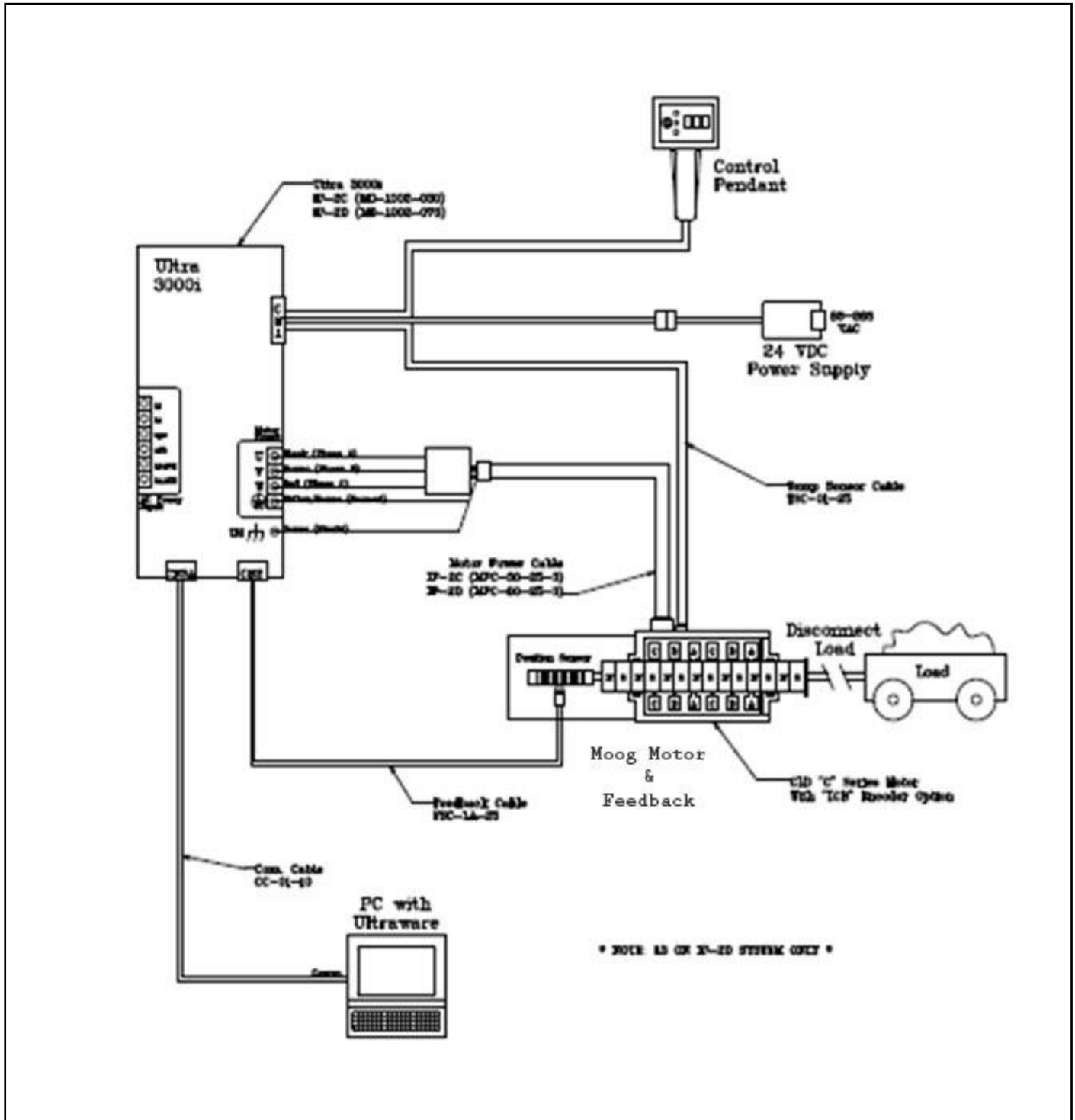

Figure 4.4
Interconnections of IP-2C / IP-2D systems.

4.4.1. Power Cable Termination

Factory supplied motor power cables (MPC-30-25-3 for “C” series systems or MPC-60-25-3 for “D” series systems) are designed to be terminated at the drive during installation. A small portion of the cable jacket is removed which exposes the shield braid. The exposed area must be clamped to the front of the drive chassis (refer to Figure 4.2.2.2) using the clamp provided as discussed in chapter 3 of the “Ultra 3000i Intelligent Positioning Drives Installation Manual” manual provided with the drive.

The motor connection is made to the circular connector of the cable MPC-30-25-3 for “C” series systems or the MPC-60-25-3 for “D” series systems. Ensure the connector keys are aligned and fully screw the connectors together.

Installation Manual: <http://www.ab.com/manuals/gmc/2098-IN003C-EN-P-JUL01.pdf>

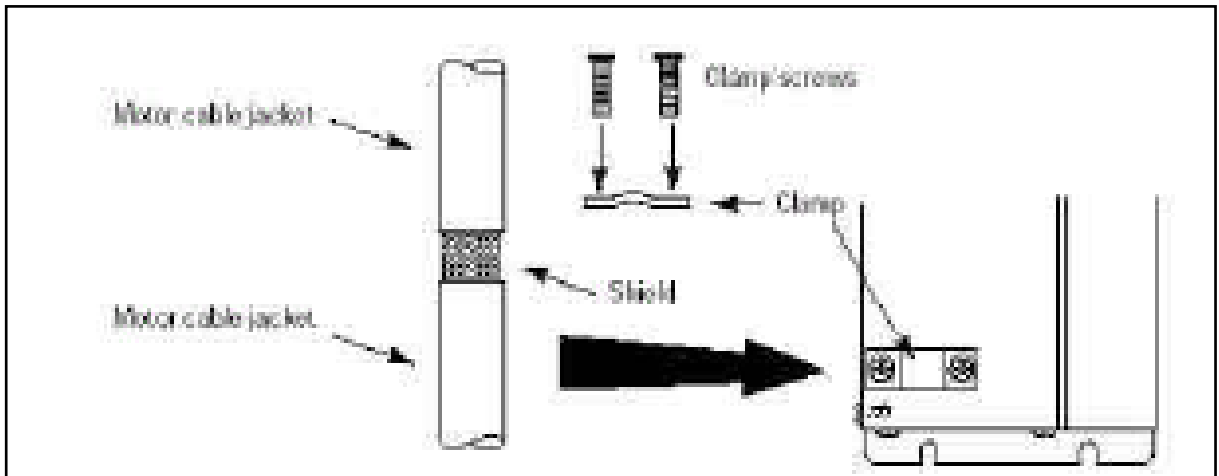

Figure 4.2.2.2
Motor Power Cable Shield Termination

4.4.2. Position Sensor (Feedback) Connection

Connect the circular connector of the FSC-LA-25 cable to the motor feedback connector. Connect the HDB15 connector of the cable to the CN2 connector on the Ultra 3000i drive.

4.4.3. I/O Connections:

The Control Pendant, 24 VDC I/O power, and Motor Temperature Switch are connected via the 44-pin connector CN1. The system is shipped with the connector prewired.

4.4.3.1. **Pendant Connection:**

The Control Pendant is wired to a 44-pin connector for CN1 no additional connection is needed on the pendant.

4.4.3.2. **24VDC Power:**

The drive I/O requires a separate 24 VDC power supply. Connect the 24VDC power supply to the Pigtail on the 44-pin CN1 connector.

4.4.3.3. **Over Temperature Sense Cable:**

One end of the Over Temperature Sense cable TSC-01-25 is prewired to the 44-pin CN1 connector. Connect the other end to the motor Over Temperature Sense connector on the motor.

4.4.4. **Communication Cable Connection:**

The communication cable CC-01-10 is connected between CN3 on the drive and the 9 pin male RS-232 connection on the Host PC.

4.4.5. **System AC Power**

The systems use 208-240 Vac 50/60 Hz applied to the power terminals of the drive through a fused properly sized disconnect. Use slow blow fuses to prevent nuisance trips. Refer to Allen-Bradley Installation Manual pg 1-7 for more information.

	Number	Line	Number of	Fuse
System:	Phases:	Names:	Contacts:	Size:
IP-2C	Single	L1, L2	2	28 amp
IP-2D	Three	L1, L2, L3	3	30 amp

The DC power supply is a dual voltage power supply capable of operating from 85-265 VAC. It can be connected to a standard 110VAC outlet or 240VAC used for the drive. Use a separate **1-amp** slow blow fuse to protect the power supply.

AC Power should be applied observing all the cautions and safety requirements typical of any equipment with this level of power. Ensure the system is well grounded before applying power. The Allen-Bradley Ultra 3000i Installation Manual (2098-IN003C-EN-P) contains detailed information on interconnection of the drive and should be referenced. Ensure all relevant electrical codes and standards are followed in accordance with all local and national codes and laws.

Installation Manual: <http://www.ab.com/manuals/gmc/2098-IN003C-EN-P-JUL01.pdf>

5. Creating Basic Motion with the System:

After the system has been connected per section 4 and all the relevant Allen-Bradley instructions contained in the Ultra 3000i Installation Manual 2098-IN003C-EN-P have been followed the system is ready to begin motion. At this point the Moog motor should not be connected to any load and the shaft should be fully retracted. Before applying power ensure that no damage or injury will occur if shaft moves rapidly to full extension.

Installation Manual: <http://www.ab.com/manuals/gmc/2098-IN003C-EN-P-JUL01.pdf>

5.1. Configuring the Ultra 3000i Drive:

The first step in using the Ultra 3000i is to configure the drive. Moog has created a preset configuration designed to work with the inputs from the Moog Control Pendant CP-0104-04.



WARNING: Keep fingers and limbs clear of the motor and moving parts when power is applied to the motor.

5.1.1. Establishing Communication and Installing Drive Configuration:

The first step in setting up the drive is to install the IP-2D Drive Configuration.

1. Apply AC power to the drive.
2. Click on the Windows **Start** button
3. Selecting **Programs, Ultraware, and Ultraware** to begin the Ultraware software.
4. Select **Open existing file** then
5. Using the open file window select the file location to which you copied the Moog data disk directories. Select the *Ultra 3000i Configurations* directory and click on *MOOG-Demo Ultra 3000i Rev A.udb*) and

Example: (C:\Program Files\Rockwell Automation\Ultraware\ *Ultra 3000i Configurations* \ *MOOG-Demo Ultra 3000i Rev A.udb*)

6. The system will detect the attached drive and ask to select drive. Select
The system will ask the same question again. Select

7. The system will again give an information message stating that presets are ignored. Select **OK**.
8. The system will begin to search for attached drives. After the software has counted to 3 select **Stop Scan**.
9. At this point the system should show a series of folders each with a drive in the work space. The top folder is On-Line Drives containing a 3k drive with bottom folder Off-Line Drives containing 3k MOOG-Demo.
10. Drag and drop the Off-Line Drive *3k MOOG-Demo* onto the On-Line Drive *3k* icon.
11. Respond to Yes that you wish to replace the drive and a copying window should proceed with the copy process.
12. Once copy disappears the process is complete. Under the folder On-Line Drives *3k MOOG-Demo* should now appear.

5.1.2. Importing Moog Motor Parameters:

Use the following steps to insert the Moog motor parameters into the Allen-Bradley Motor Database file:

1. Clicking on the Windows **Start** button.
2. Selecting Programs, **Ultraware**, and **Motor Configuration** to display the Open Motor Data window, and Open the file **Motors.mdb** from the Ultraware directory to display the Motor Database window.
3. Click on **File** in the Main Menu bar of the Motor Configuration Program.
4. Select **Import** on the dropdown menu.
5. Using the import file window select the file location to which you copied the Moog data disk directories. Select the *AB Motor Files* directory and double click the Motor Exchange File (.mxf) that represents your motor part number.

Example: (C:\Program Files\Rockwell Automation\Ultraware\AB Motor Files\MOOG5020XXT-LCB-CV.mxf)

6. Scroll down the list of motors to ensure that the motor Part Number has been inserted.
7. Exit the Motor Database window.

5.1.3. Inserting Moog Motor Parameters:

Power up the drive and Establish communications between the host computer and the Allen-Bradley drive in accordance with Allen-Bradley Ultraware Users Manual 2098-UM001D-EN-P. Drive communication is described in Chapter 1.

Communication is established when a 3K Ultra Drive icon appears on the tree.

Users Manual: <http://www.ab.com/manuals/gmc/2098-UM001D-EN-P-AUG01.pdf>

Load the appropriate Moog motor into the Ultra 3000i drive:

1. Click on the Windows **Start** button
2. Selecting **Programs, Ultraware,** and **Ultraware** to begin the Ultraware software.
3. Select **Create new file** then .
4. The system will start searching for connected drives. Select . Once drive 1 has been detected.
5. Expand the Ultra 3000i tree in the Ultraware by selecting
6. Double click the icon on the tree to open the motor parameter window.
7. Click on the **Auto Motor Iden** scroll bar and select
8. Click on **Motor Model** scroll bar and select the appropriate Moog motor model from the list . Ensure listed motor parameters change.
9. Change the **Total Moving Mass** to that listed in the table below:

Motors	Mass (kg)					
	2"	4"	6"	8"	10"	12"
40202.../50202...	3.6	4.2	4.8	5.5	6.1	6.8
40204.../50204...	4.8	5.5	6.1	6.8	7.4	8.1
40206.../50206...	6.1	6.8	7.4	8.1	8.8	9.5

NOTE: When the load is attached the shaft moving mass will need to be changed to the total mass of the shaft plus load.

5.2. Setting Initial Tuning Values:

Basic tuning parameters need to be set in the Ultra 3000i drive to for basic motion to occur. The Moog motor parameters need to be loaded into the Ultra 3000i drive. This is accomplished through the following steps:

1. Open the Tuning window by clicking on Tuning icon under Ultra 5K.
2. Expand the Velocity Regulator Gains by clicking on the +. Set the values listed in Table 5.1.
3. Expand the Position Regulator Gains by clicking on the +. Set the values listed in Table 5.2

Do not attempt to use the Autotuning function in the Ultraware. Large rapid motions may occur and cause damage to the motor or drive.

Table 5.1

P	380
I	0
FF	1
Bandwidth	0
Upper Limit	30
Lower Limit	-30

Table 5.2

Kp	400
Kpz	0
Kpz zone	0
Ki	0
Ki zone	0
Kff	5

5.3. Running the system:

The system is now ready to be run using the pendant. Ensure no persons are in a position where the motor shaft rapidly extending or retracting could cause an injury.

The system is Enabled by selecting enable with the enable switch. The motor will fully retract then slightly extend to its home position, and is ready to run a motion sequence.

The individual sequences are chosen by setting a binary code determined by the positions of the sequence selection switches and then pressing the start button. The system is programmed with 8 different preprogram sequences which are selected with the binary coding of the individual switch positions of SW0, SW1, and SW2. The table 5.3.1 lists the coding and switch positions.

5.3.1. Description of Pendant:

1. **Disable/Enable:** In the Disable position the system is disabled from moving electronically by the drive. When put into the Enable position the drive will find home initially and will be ready for a commanded sequence.
2. **Enable Fault Indicator:** Green indicates the system is enabled and ready to start a sequence. Red indicates a fault has occurred. Off indicates that the system is not enabled or has no power.
3. **Home:** When pressed present sequence will stop and return the motor home and ready to begin another sequence.
4. **Start:** When pressed the sequence selected by the selection switches will begin.
5. **Sequence Selection Switch 0:** The least significant bit used for sequence selection. It is a lighted switch. When lit the switch is on.
6. **Sequence Selection Switch 1:** The second significant bit used for sequence selection. It is a lighted switch. When lit the switch is on.
7. **Sequence Selection Switch 2:** The most significant bit used for sequence selection. It is a lighted switch. When lit the switch is on.

Table 5.3.1

Sequence:	SW-2	SW-1	SW-0
0	off	off	off
1	off	off	on
2	off	on	off
3	off	on	on
4	on	off	off
5	on	off	on
6	on	on	off
7	on	on	on

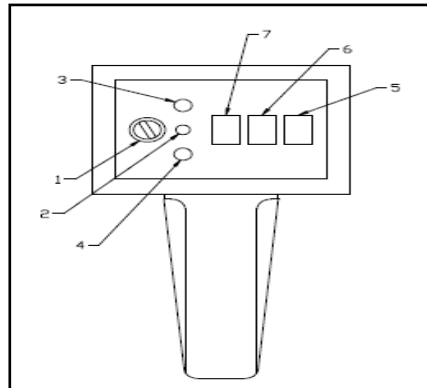

Figure 5.3.1
Pendant Switch Layout

6. Tuning System:

The tuning parameters entered in Section 5.3 are basic parameters used to create motion that is not necessarily precise. The system should be tuned in accordance with the Allen-Bradley instructions. Do not expect the system to have precise motion with the initial tuning parameters.



WARNING: Improper Servo tuning can cause uncontrolled motion of the Moog motor. Do not allow the system to oscillate during the tuning process, and keep all personnel and body parts away from moving equipment.

Appendix-A: (Revision History)

<i>ECO #</i>	<i>Revision</i>	<i>Change</i>	<i>Date</i>
0130	A	Initial Release	12/09/03
	B	Change to Moog	8/10/09

