

REVISIONS				
ZONE	REV.	DESCRIPTION	DATE	APPROVED
	A	NEW DRAWING/NTD 10178		

8X 22 AWG
UL 3265; 125°C, 150V

LABEL PRINTED AS FOLLOWS:
COMPANY NAME
UNIT TYPE
DATE CODE

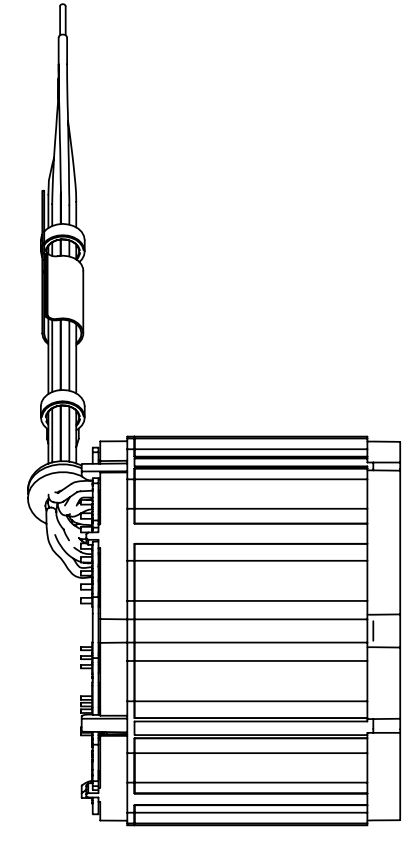
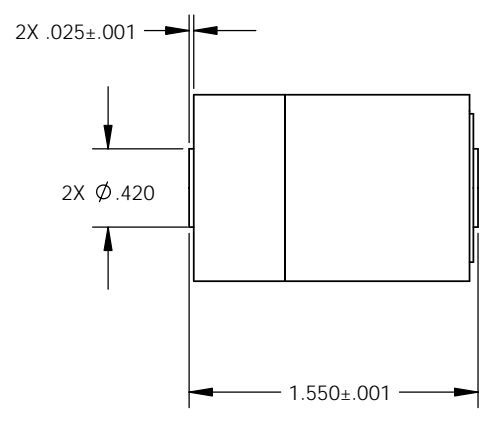
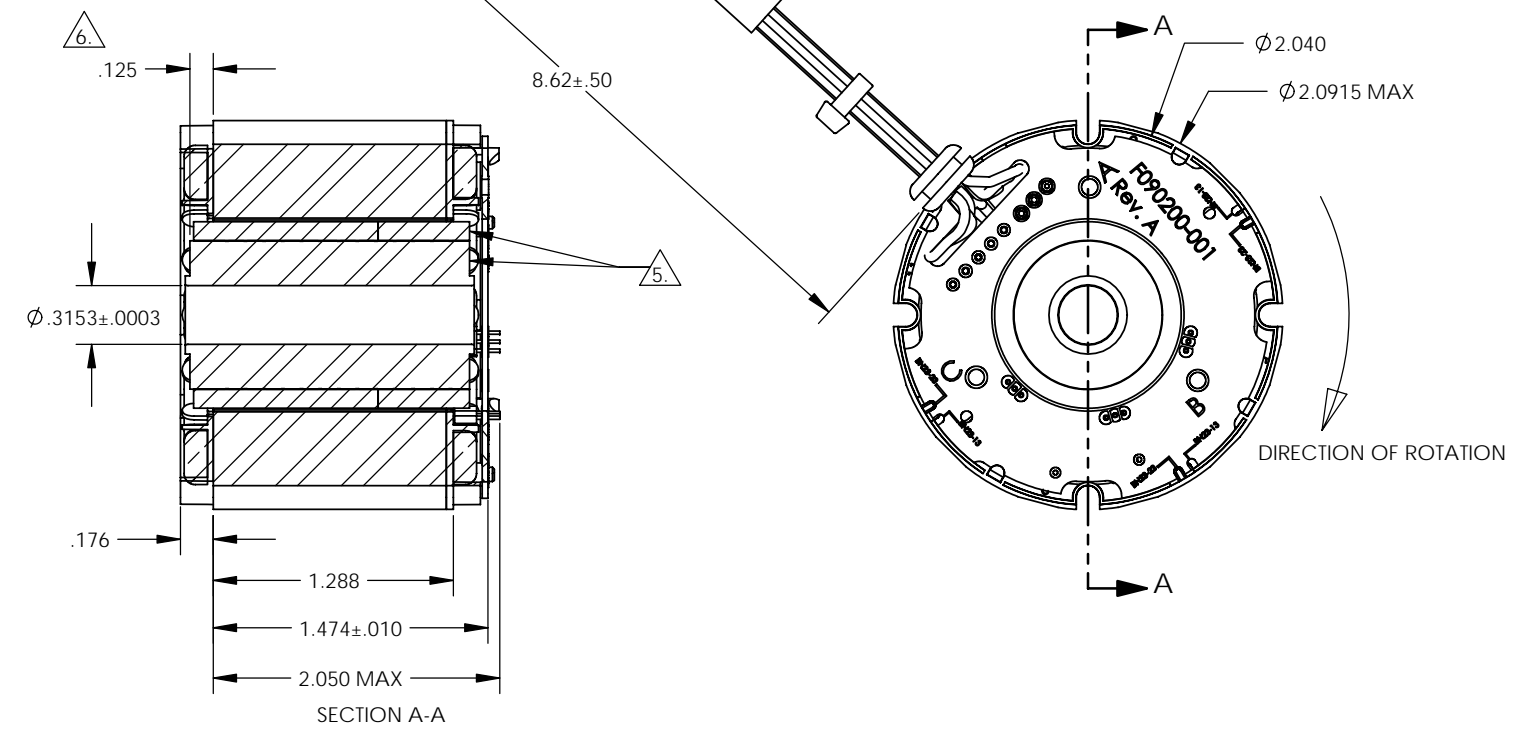

NOTES UNLESS OTHERWISE SPECIFIED:

1. INTERPRET DRAWING PER ASME Y14.100.
2. OPEN COLLECTOR OUTPUTS, USE PULL UP RESISTORS BETWEEN V_{CC} AND OUTPUTS.
3. TESTED AS A MOTOR ASSEMBLY MOUNTED TO 6" X 6" X 1/4" ALUMINUM PLATE, STILL AIR.
4. MAXIMUM WINDING TEMPERATURE OF 155°C.
5. MAGNET RING AND ROTOR CORE: FLUSH ±.002 ON THIS SIDE.
6. RECOMENDED ROTOR CORE TO STACK MOUNTING DIMENSION.

PERFORMANCE AT 25°C				
PARAMETER	SYMBOL	UNITS	TOLERANCE	VALUE
TERMINAL VOLTAGE	V	VOLTS DC	NOMINAL	24
PEAK TORQUE	T _P	OZ-IN	MAXIMUM	143
CONTINUOUS STALL TORQUE	T _C ¹	OZ-IN	MAXIMUM	42.8
NO LOAD SPEED	S _{NL}	RPM	NOMINAL	8100
RATED SPEED	S _R	RPM		6060
RATED TORQUE		OZ-IN	MAXIMUM	40.3
RATED CURRENT		AMPS		9.47
RATED POWER		WATTS		181
TORQUE SENSITIVITY	K _T	OZ-IN/AMP	±10%	3.85
BEMF CONSTANT	K _E	VOLTS/KRPM	±10%	2.85
TERMINAL RESISTANCE	R _M	OHMS	±12%	0.178
TERMINAL INDUCTANCE	L _M	mH	±30%	0.220
MOTOR CONSTANT	K _M	OZ-IN/? WATTS	NOMINAL	9.13
SPEED TORQUE GRADIENT		RPM/OZ-IN		50.60
MECHANICAL TIME CONSTANT		msec		2.50
ELECTRICAL TIME CONSTANT		msec		1.24
THERMAL RESISTIVITY		°C/WATT		2.36

TERMINATION TABLE	
COLOR	CONNECTION
VIOLET	A COIL
BLACK	B COIL
GREEN	C COIL
YELLOW	V _{CC}
GREY	GROUND
BROWN	S1 OUT
BLUE	S2 OUT
WHITE	S3 OUT

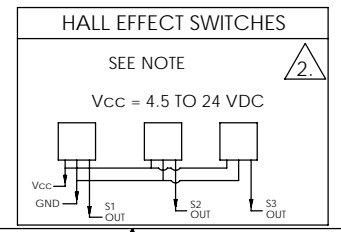
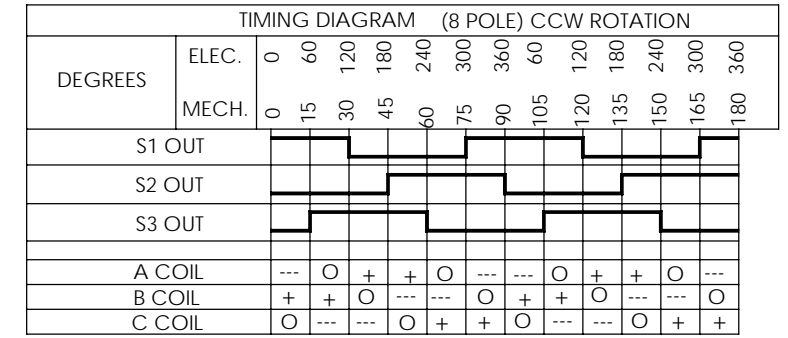

UNLESS OTHERWISE SPECIFIED DIMENSIONS ARE IN INCHES		CAD GENERATED DRAWING, DO NOT MANUALLY UPDATE					
TOLERANCES ARE:		APPROVALS				DATE	
DECIMALS	ANGLES	DRAWN		R. PACE		1/31/06	
.XX ±.010	±0°30'	CHECKED		R. MARTIN		2/10/06	
.XXX ±.005	FRACTIONS	ENGR		D. THOMPSON		2/10/06	
.XXXX ±.0005	±1/64	RELEASED		R. MARTIN		2/14/06	
DO NOT SCALE DRAWING		MFG ENGR		L. FORRISTER		2/13/06	
MATERIAL		SHOP ENGR					
FINISH		D/A		B. LITTLE		2/10/06	
TITLE		CAGE CODE		DWG. NO.		SCALE	
BRUSHLESS D.C. MOTOR		4H618		BN23-23ZMG-01LH		1.5:1	
OUTLINE		BN23-23ZMG-01LH		SHEET 1 OF 1			