

# Silencer® Series Brushless DC Motor

## TYPICAL APPLICATIONS

- Commercial and military aerospace
- Computer-controlled embroidery machines
- Scanners
- Packaging equipment and printing products
- HVAC equipment (air moving)
- Robotics applications
- Semiconductor handling and insertion machines
- Actuators
- Battery-powered medical applications
  - Portable oxygen concentrators
  - Mobility and patient assistance

## FEATURES

- Inside rotor construction for quick acceleration
- 8 pole motor
- Compact size – 1.9 inches long
- Diameter size – 2.25 inches
- Continuous torque up to 57 oz-in
- High energy sintered neodymium magnets
- Safe, arcless operation
- High torque per dollar ratio
- Unique stator construction - optimal copper slot fill for high motor constant (Km)

## BENEFITS

- Operation at any single speed - not limited to AC frequency
- Motor life is not limited to brush or commutator life
- An essentially linear speed / torque curve
- Efficient operation without losses associated with brushes and commutation or armature induction
- Precise, variable speed control
- Extremely quiet operation
- Long-life operation
- High performance in a compact package

## BSG23 High Performance Unique Stator Design



### **Quiet, Brushless Motors**

Utilizing high energy sintered neodymium magnets and a unique stator design, the BSG23 brushless motor offers over two times the torque capability of our standard BN23 brushless motor. Ideal for applications where maximum performance and compact size are critical. Designed for maximum efficiency, this motor is a viable alternative to costly traditional brushless DC servo motors.

Typical options include electronic drives, encoders, gearheads, as well as Hall effect, resolvers, sensorless feedback and black finned aluminum housing (for additional heat transfer).

For more information about how this product can be tailored to fit your specific application, contact our applications engineers.

## SPECIFICATION AND NUMBERING SYSTEM

### Part Numbering System Guide

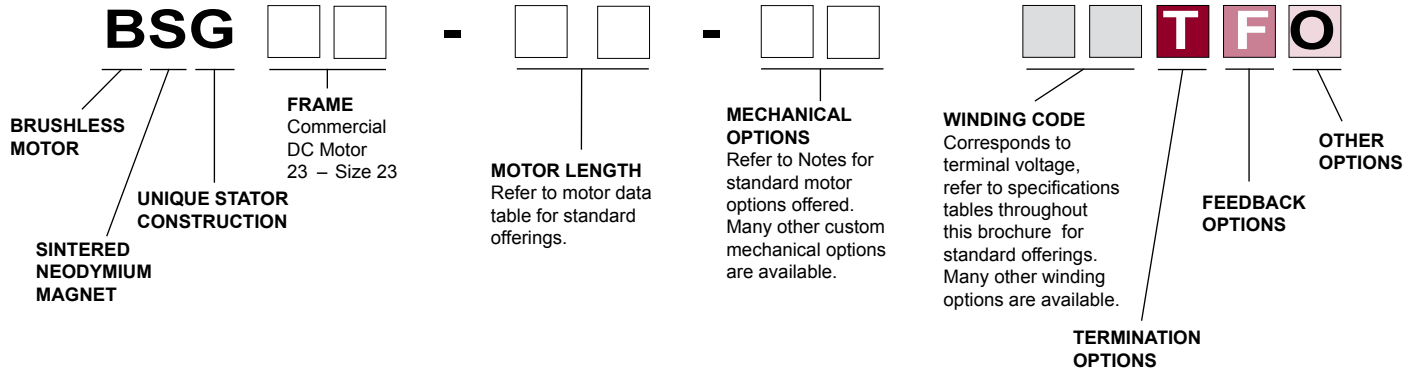

## BSG23-18 SPECIFICATIONS - Continuous Stall Torque 49 - 62 oz-in (0.35 - 0.44 Nm) Peak Torque 300 oz-in (2.1 Nm)

| Part Number*             |  | BSG23-18AB- [ ] [ ] [ ] [ ] [ ] [ ] |        |        |
|--------------------------|--|-------------------------------------|--------|--------|
| Winding Code**           |  | 01                                  | 02     | 03     |
| L = Length               | inches                                   | 1.90                                |        |        |
|                          | millimeters                              | 48.26                               |        |        |
| Terminal Voltage         | volts DC                                 | 12                                  | 24     | 48     |
| Peak Torque              | oz-in                                    | 300                                 | 300    | 300    |
|                          | Nm                                       | 2.1                                 | 2.1    | 2.1    |
| Continuous Stall Torque  | oz-in                                    | 47                                  | 56     | 59     |
|                          | Nm                                       | 0.33                                | 0.40   | 0.42   |
| Rated Speed              | RPM                                      | 4000                                | 4000   | 4000   |
|                          | rad/sec                                  | 419                                 | 419    | 419    |
| Rated Torque             | oz-in                                    | 45                                  | 54     | 57     |
|                          | Nm                                       | 0.32                                | 0.38   | 0.40   |
| Rated Current            | Amps                                     | 14.0                                | 8.4    | 4.7    |
|                          | watts                                    | 133.14                              | 159.76 | 168.64 |
| Torque Sensitivity       | oz-in/amp                                | 3.54                                | 7.08   | 14.0   |
|                          | Nm/amp                                   | 0.025                               | 0.050  | 0.099  |
| Back EMF                 | volts/KRPM                               | 2.62                                | 5.24   | 10.35  |
|                          | volts/rad/sec                            | 0.025                               | 0.050  | 0.099  |
| Terminal Resistance      | ohms                                     | 0.10                                | 0.28   | 1.00   |
| Terminal Inductance      | mH                                       | 0.12                                | 0.46   | 1.84   |
| Motor Constant           | oz-in/sq.rt.watt                         | 11.19                               | 13.38  | 14.00  |
|                          | Nm/sq.rt.watt                            | 0.079                               | 0.094  | 0.099  |
| Rotor Inertia            | oz-in-sec <sup>2</sup> x10 <sup>-3</sup> | 0.99                                | 0.99   | 0.99   |
|                          | g-cm <sup>2</sup>                        | 69.9                                | 69.9   | 69.9   |
| Weight                   | oz                                       | 17                                  | 17     | 17     |
|                          | g  | 483                                 | 483    | 483    |
| # of Poles               |  | 8                                   | 8      | 8      |
| Timing                   |  | 120°                                | 120°   | 120°   |
| Mech. Time Constant      | ms                                       | 1.12                                | 0.78   | 0.72   |
| Electrical Time Constant | ms                                       | 1.15                                | 1.64   | 1.84   |
| Thermal Resistivity      | deg. C/watt                              | 3.00                                | 3.00   | 3.00   |
| Speed/Torque Gradient    | rpm/oz-in                                | 13.0                                | 10.8   | 11.2   |
| No Load                  | rpm                                      | 4600                                | 4600   | 4600   |

### Timing Diagram for Hall Switches

| DEGREES | ELEC   |                  |    |     |     |     |     |     |     |     |     |     |     |     |  |
|---------|--------|------------------|----|-----|-----|-----|-----|-----|-----|-----|-----|-----|-----|-----|--|
|         |        | 0                | 60 | 120 | 180 | 240 | 300 | 360 | 60  | 120 | 180 | 240 | 300 | 360 |  |
|         | MECH   | 0                | 15 | 30  | 45  | 60  | 75  | 90  | 105 | 120 | 135 | 150 | 165 | 180 |  |
|         | S1 OUT | [Timing Diagram] |    |     |     |     |     |     |     |     |     |     |     |     |  |
|         | S2 OUT | [Timing Diagram] |    |     |     |     |     |     |     |     |     |     |     |     |  |
|         | S3 OUT | [Timing Diagram] |    |     |     |     |     |     |     |     |     |     |     |     |  |
|         | A COIL | -                | 0  | +   | +   | 0   | -   | -   | 0   | +   | +   | 0   | -   | -   |  |
|         | B COIL | +                | +  | 0   | -   | -   | 0   | +   | +   | 0   | -   | -   | 0   | +   |  |
|         | C COIL | 0                | -  | -   | 0   | +   | +   | 0   | -   | -   | 0   | +   | +   | 0   |  |

### Hall Effect Switches

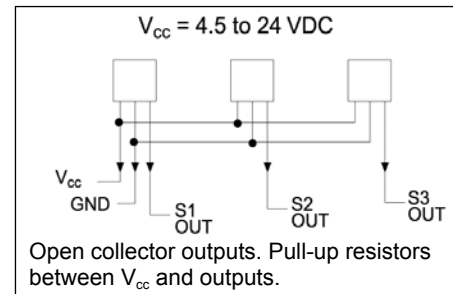

#### Notes:

- Motor mounted to a 4" x 4" x 1/4" aluminum plate, still air.
- Maximum winding temperature of 155°C.
- Typical electrical specifications at 25°C.
- Motor Terminal Voltages are representative only; motors may be operated at voltages other than those listed in the table. For assistance please contact our applications engineer.
- Calculated (theoretical) speed/torque gradient.

\*Many other custom mechanical options are available – consult factory.  
\*\*Many other winding options are available – consult factory.

Select your options below and place their code in its corresponding block as shown above.

- |                      |                           |                        |
|----------------------|---------------------------|------------------------|
| <b>T</b> TERMINATION | <b>F</b> FEEDBACK OPTIONS | <b>O</b> OTHER OPTIONS |
| L – Leads (std)      | H – Hall Effect (std)     | D – Drive              |
| C – Connector        | R – Resolver              | G – Gearhead           |
| M – MS connector     | S – Sensorless            | E – Encoder            |

# Brushless Motors

## BSG23-18 Typical Outline

Termination Table\*

| CONNECTION | LEAD COLOR |
|------------|------------|
| Vcc        | YELLOW     |
| GROUND     | GRAY       |
| A COIL     | VIOLET     |
| B COIL     | BLACK      |
| C COIL     | GREEN      |
| S2 OUT     | BLUE       |
| S1 OUT     | BROWN      |
| S3 OUT     | WHITE      |

\*We reserve the right to use solid color wires or white wires with color trace.

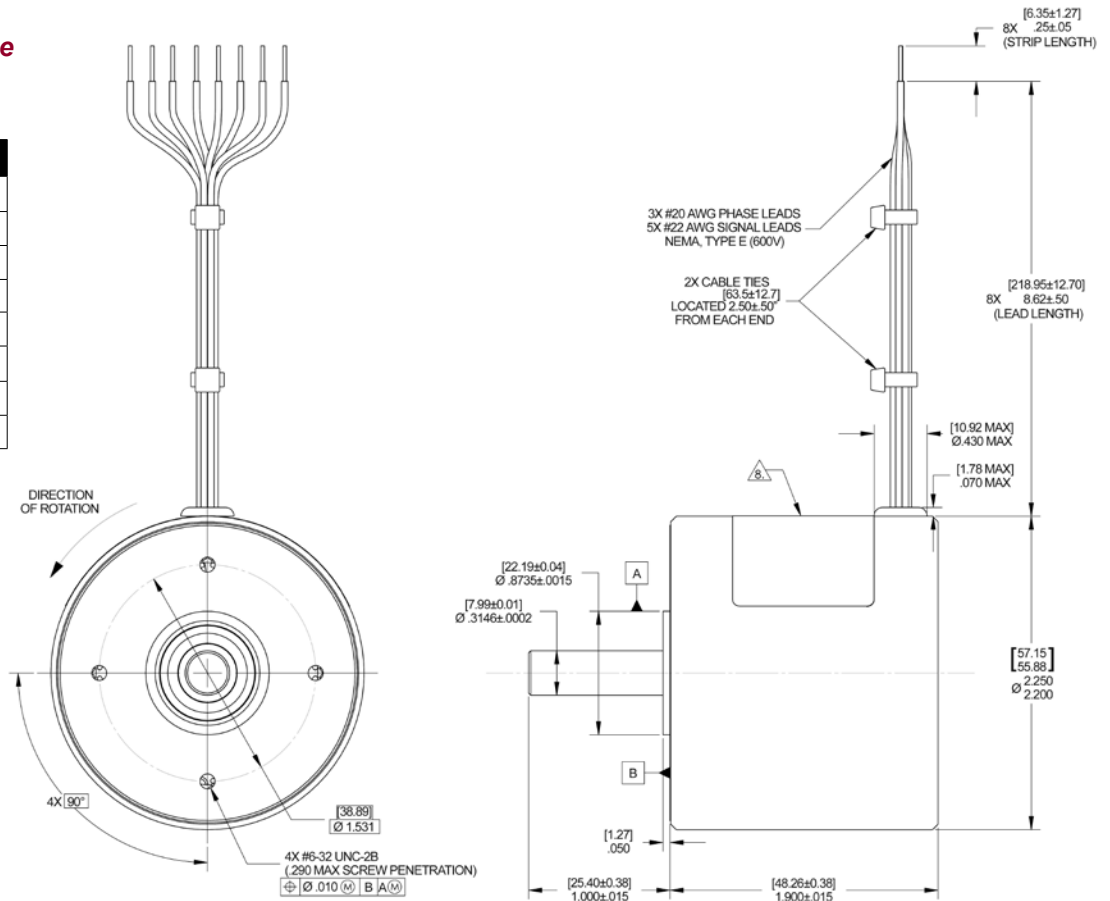

Dimensions are in inches [mm]

## BSG23-18 Performance Curves

BSG23-18 [ ]-01LH: Continuous & Intermittent Operation at 12 Volt DC

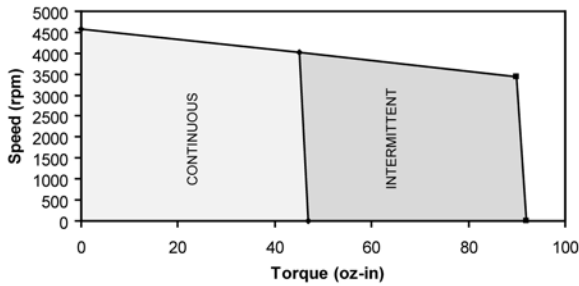

BSG23-18 [ ]-02LH: Continuous & Intermittent Operation at 24 Volt DC

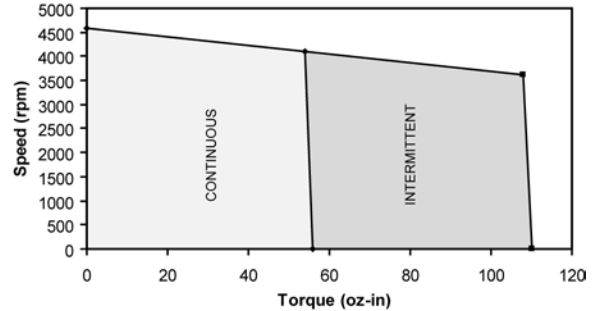

BSG23-18 [ ]-03LH: Continuous & Intermittent Operation at 48 Volt DC

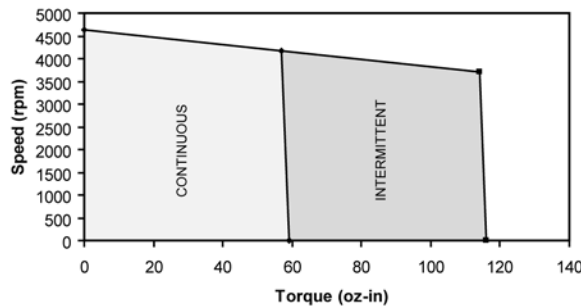

**Note:** Intermittent operation is based on a 20% duty cycle of one minute on, four minutes off. Please contact the factory regarding the duty cycle of your application.