

Silencer® Series Brushless DC Motor

BSG34 High Performance Unique Stator Design



Quiet, Brushless Motors

Utilizing high energy sintered neodymium magnets and a unique stator design, the BSG34 brushless motor offers over two times the torque capability of our standard BN34 brushless motor. Ideal for applications where maximum performance and compact size are critical. Designed for maximum efficiency, this motor is a viable alternative to costly traditional brushless DC servo motors.

Typical options include electronic drives, encoders, gearheads, as well as Hall effect, resolvers, sensorless feedback and black finned aluminum housing (for additional heat transfer).

For more information about how this product can be tailored to fit your specific application, contact our applications engineers.

TYPICAL APPLICATIONS

- Commercial and military aerospace
- Computer-controlled embroidery machines
- Scanners
- Packaging equipment and printing products
- HVAC equipment (air moving)
- Robotics
- Semiconductor handling and insertion machines
- Actuators
- Factory automation
- Fuel cells

FEATURES

- Inside rotor construction for quick acceleration
- 8 pole motor
- Compact size, 3.5 inches long
- Diameter size, 3.4 inches
- Continuous torque up to 310 oz-in
- High energy sintered neodymium magnets
- Safe, arcless operation
- High torque per dollar ratio
- Unique stator construction - optimal copper slot fill for high motor constant (Km)

BENEFITS

- Operation at any single speed - not limited to AC frequency
- Motor life is not limited to brush or commutator life
- An essentially linear speed / torque curve
- Efficient operation without losses associated with brushes and commutation or armature induction
- Precise, variable speed control
- Extremely quiet operation
- Long-life operation
- High performance in a compact package

Note: This catalog contains basic marketing information and general part descriptions of Moog Components Group product lines. With respect to the U.S. export regulations, the products described herein are controlled by the U.S. Commerce Department or the U.S. State Department. Contact Moog Components Group for additional detail on the export controls that are applicable to your part.

BSG34-38 Specifications

Inside Rotor
Brushless Motors

SPECIFICATION AND NUMBERING SYSTEM

Part Numbering System Guide

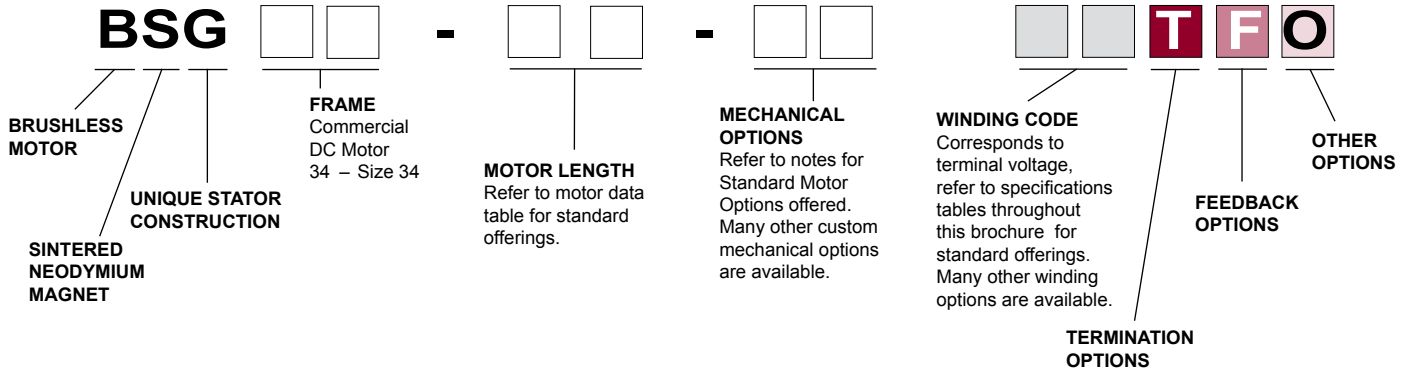

BSG34-38 SPECIFICATIONS - Peak Torque 1950 oz-in (13.77 Nm)

Part Number*		BSG34-38AC- [] [] T F O []
Winding Code**		01
L = Length	inches	3.50
	millimeters	88.90
Terminal Voltage	volts DC	24
Peak Torque	oz-in	1950
	Nm	13.77
Rated Speed	RPM	3180
	rad/sec	333
Rated Torque	oz-in	310
	Nm	2.10
Rated Current	Amps	34
Rated Power	watts	729
Torque Sensitivity	oz-in/amp	9.51
	Nm/amp	0.07
Back EMF	volts/KRPM	7.04
	volts/rad/sec	0.07
Terminal Resistance	ohms	0.34
Terminal Inductance	mH	0.21
Motor Constant	oz-in/sq.rt.watt	57.57
	Nm/sq.rt.watt	0.36
Rotor Inertia	oz-in-sec ² x10 ⁻³	14.80
	g-cm ²	1045.18
Weight	oz	72
	g	2041.2
# of Poles		8
Timing		120°
Mech. Time Constant	ms	0.27
Electrical Time Constant	ms	3.95
Thermal Resistivity	deg. C/watt	1.40
Speed/Torque Gradient	rpm/oz-in	0.52
No Load	rpm	3409

Timing Diagram for Hall Switches

DEGREES	ELEC												
	0	60	120	180	240	300	360	60	120	180	240	300	360
	MECH												
	0	15	30	45	60	75	90	105	120	135	150	165	180
S1 OUT	[Timing diagram showing S1 OUT pulses]												
S2 OUT	[Timing diagram showing S2 OUT pulses]												
S3 OUT	[Timing diagram showing S3 OUT pulses]												
A COIL	-	0	+	+	0	-	-	0	+	+	0	-	
B COIL	+	+	0	-	-	0	+	+	0	-	-	0	
C COIL	0	-	-	0	+	+	0	-	-	0	+	+	

Hall Effect Switches

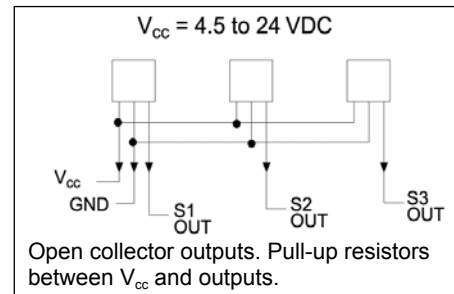

Notes:

- Motor mounted to a 4 x 4 x 1/4 inches aluminum plate, still air.
- Maximum winding temperature of 155°C.
- Typical electrical specifications at 25°C.
- Motor Terminal Voltages are representative only; motors may be operated at voltages other than those listed in the table. For assistance please contact our applications engineer.
- Calculated (theoretical) speed/torque gradient.

*Many other custom mechanical options are available – consult factory.
**Many other winding options are available – consult factory.

Select your options below and place their code in its corresponding block as shown above.

- | | | |
|----------------------|---------------------------|------------------------|
| T TERMINATION | F FEEDBACK OPTIONS | O OTHER OPTIONS |
| L – Leads (std) | H – Hall Effect (std) | D – Drive |
| C – Connector | R – Resolver | G – Gearhead |
| M – MS connector | S – Sensorless | E – Encoder |

BSG34-38 Performance Curves

Inside Rotor
Brushless Motors

BSG34 Typical Outline

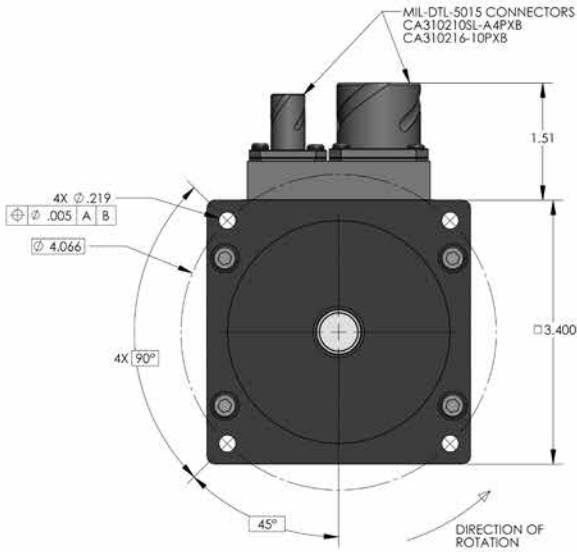

Termination Table*

CONNECTION	LEAD COLOR
V _{cc}	YELLOW
GROUND	GRAY
A COIL	RED
B COIL	BLACK
C COIL	GREEN
S1 OUT	BROWN
S2 OUT	BLUE
S3 OUT	ORANGE

*We reserve the right to use solid color wires or white wires with color trace.

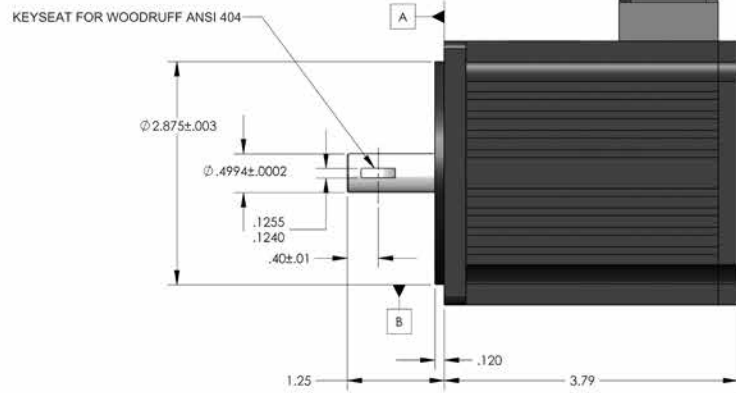

Dimensions are in inches

BSG34 Performance Curves

BSG34-38AC-01LH: Continuous & Intermittent Operation at 24 Volt DC

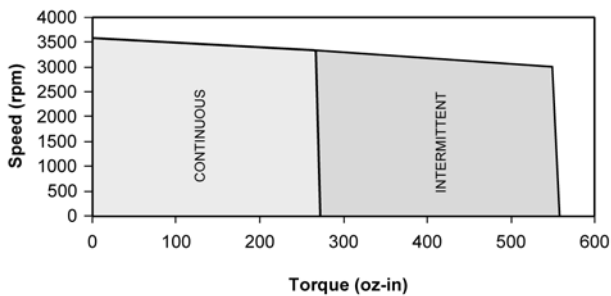

Note: Intermittent operation is based on a 20% duty cycle of one minute on, four minutes off. Please contact the factory regarding the duty cycle of your application.