

Brush Motors

D-2813-G-1HT SPECIFICATIONS @ 25°C

Size Constants	Value	Units
Peak Torque, T_P	95	oz-in
Motor Constant, K_M	15.3	oz-in/ \sqrt{W}
Number of Poles	8	
Weight	21	oz (nom)
Motor Inertia, J_M	1.46E-02	oz-in-s ²
Friction Torque, T_F	2.5	oz-in
Electrical Time Constant, τ_E	0.575	ms
Mechanical Time Constant, τ_M	8.82	ms
Temperature Rise, Housed TPR'	7	° C/W
Ripple Torque, T_R	5	max. avg. to peak (%)
Winding Constants	Value	Units
Torque Sensitivity, K_T	43.3	oz-in/amp
Back EMF, K_E	0.306	V per rad/s
Terminal Resistance, R_M	8	ohms (nom)
Terminal Inductance, L_M	4.6	mH (nom)
Voltage, Stalled at Peak Torque, V_P	17.6	volts
Amps at Peak Torque, I_P	2.2	amps

D-2813-G-1HT Typical Outline Drawing

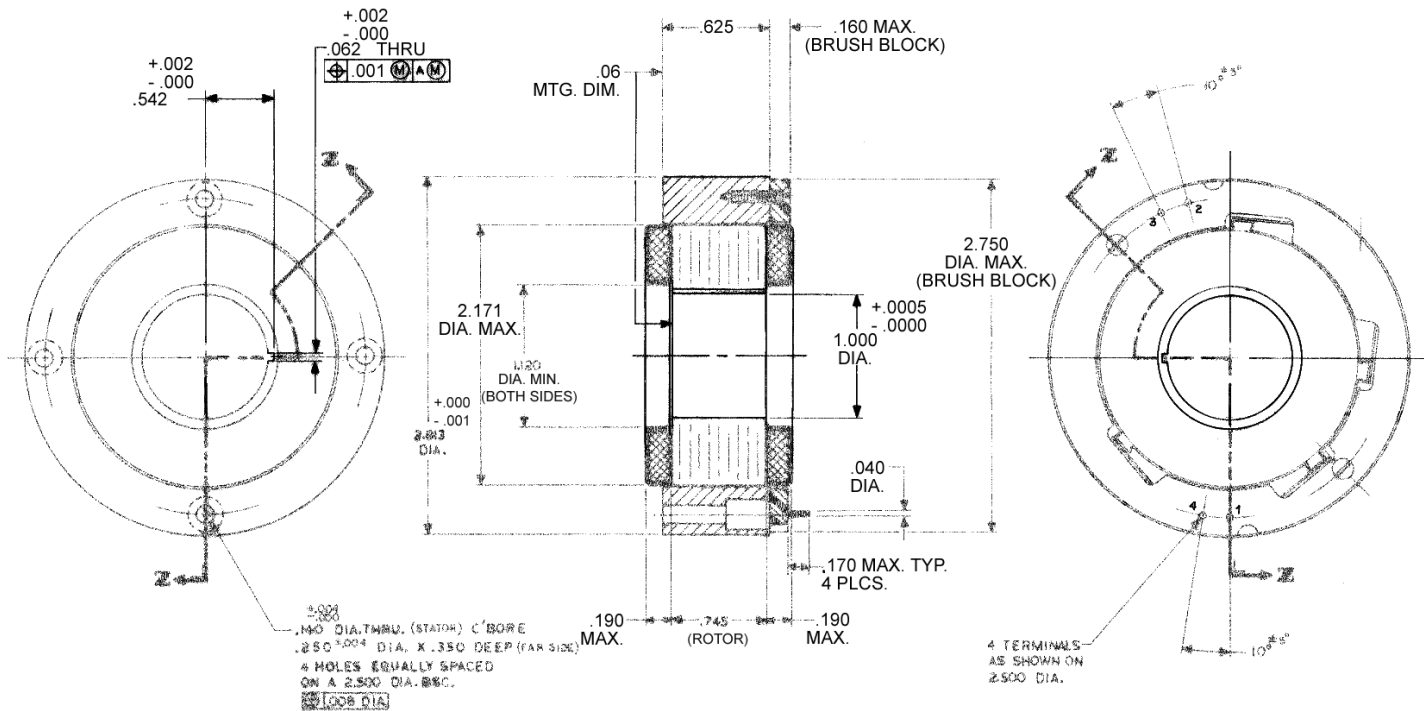

Dimensions are in inches