

Brush Motors

D-8630-C-1 SPECIFICATIONS @ 25°C

Size Constants	Value	Units
Peak Torque, T_p	160	oz-in
Motor Constant, K_M	22.1	oz-in/ \sqrt{W}
Number of Poles	16	
Weight	37	oz (nom)
Motor Inertia, J_M	1.40E-02	oz-in-s ²
Friction Torque, T_F	8	oz-in
Electrical Time Constant, τ_E	0.532	ms
Mechanical Time Constant, τ_M	40.4	ms
Temperature Rise, Housed TPR'	3	° C/W
Ripple Torque, T_R	5	max. avg. to peak (%)
Winding Constants	Value	Units
Torque Sensitivity, K_T	48	oz-in/amp
Back EMF, K_E	0.339	V per rad/s
Terminal Resistance, R_M	4.70	ohms (nom)
Terminal Inductance, L_M	2.5	mH (nom)
Voltage, Stalled at Peak Torque, V_p	15.7	volts
Amps at Peak Torque, I_p	3.34	amps

D-8630-C-1 Typical Outline Drawing

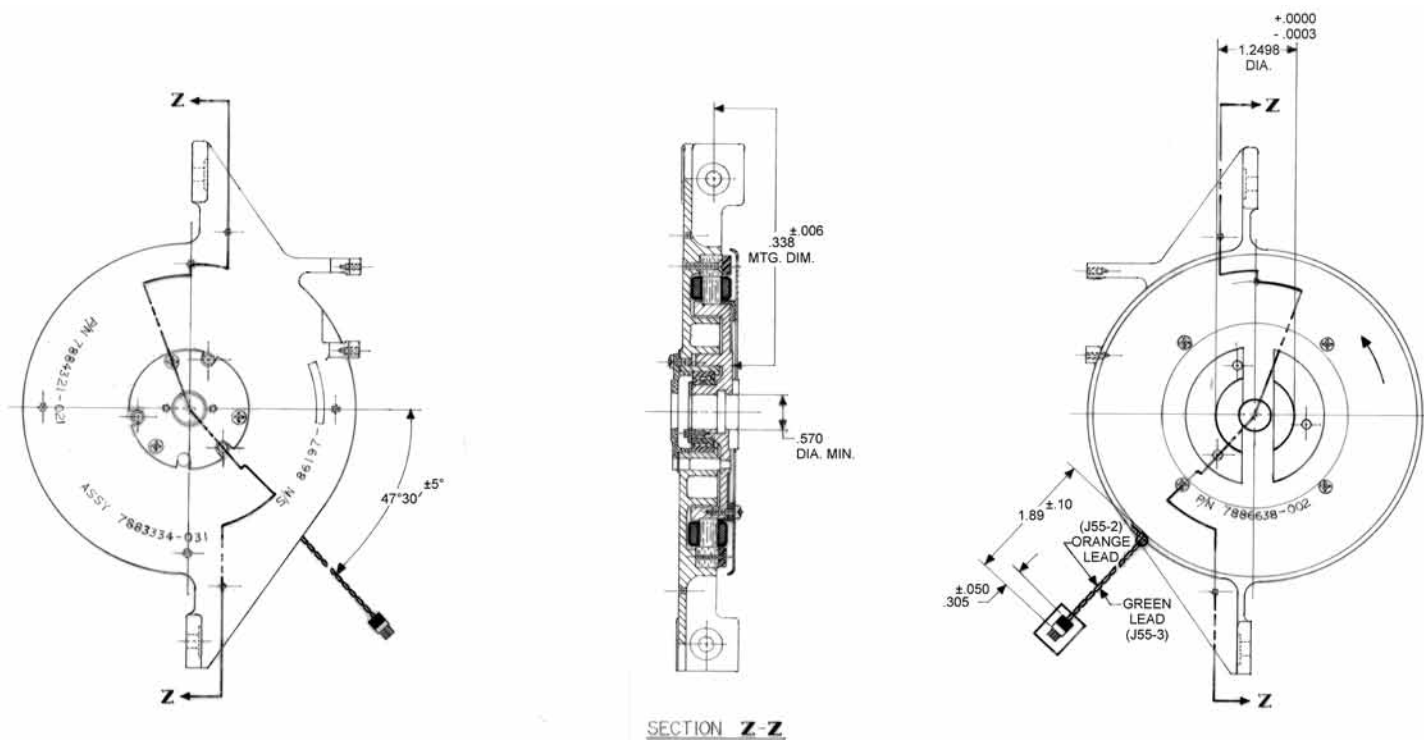

Dimensions are in inches