

High Speed Slip Ring Capsules

EC3848

High speed

Description

A slip ring can be used in any electromechanical system that requires unrestrained, continuous rotation while transmitting power and / or data from a stationary to a rotating structure. A slip ring is also called a rotary electrical interface, collector, swivel or rotary joint. A slip ring can improve system performance by simplifying operations and eliminating damage-prone wires dangling from moving joints.

The EC3848 features precious metal contacts at the rotary interface. Flying lead wires on the rotating side and solder terminals on the stator side complete the electrical connections. Precision ball bearings and the patented fiber brush design allow operation up to 10,000 rpm without the need for cooling equipment. Fiber brush technology offers several advantages over conventional slip ring contacts including multiple points of contact per brush bundle, low contact force per fiber and low contact wear rates. In addition, fiber brushes do not require lubrication and produce virtually no wear debris.

Features

- Speeds up to 10,000 rpm without cooling
- 2, 6, 8 and 10 circuit models
- Precision ball bearings
- 1 amp / 100 VDC circuits
- Precious metal contacts

Benefits

- Transfers control and data signals
- Fiber brush technology provides maintenance-free operation (no lubrication required)
- Standard design meets high speed requirements at a fraction of the cost of a custom assembly

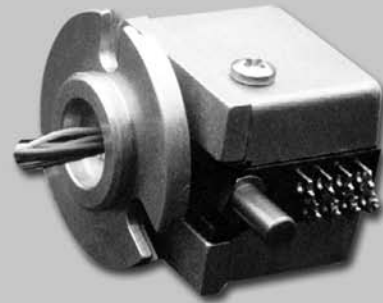

Typical Applications

- Centrifuges
- Various high speed instrumentation applications such as tire testing

High Speed Slip Ring Capsules

Specifications	
Operating Speed	0 - 10,000 rpm*
Number of Rings	Up to 10
Electrical Connections	30 (19 / 42) AWG leads on rotor Solder terminals on stator
Voltage	Low millivolt range to 100 VDC
Maximum Ambient Temperature	50°C (120°F) over 1,000 rpm 80°C (175°F) up to 1,000 rpm
Contact Material	Precious metal
Current Rating	1.0 amps maximum per ring
Insulation Resistance	1000 MΩ at 500 VDC
Electrical Noise	20 mΩ at 5 rpm 6 VDC, 50 mA current
Cooling	Not required

* Please note that the operational life of the unit is dependent upon rotational speed, environment and temperature.

Lead Wire Color Code			
Ring #	Color	Ring #	Color
1	BLK	6	GRN
2	BRN	7	BLU
3	RED	8	VIO
4	ORN	9	GRY
5	YEL	10	WHT

Part #	Length "A"
EC4294-2	0.71 inch (18,1 mm)
EC3848-6	0.91 inch (23,2 mm)
EC4199-8	1.02 inch (25,8 mm)
EC3848-10	1.11 inch (28,3 mm)

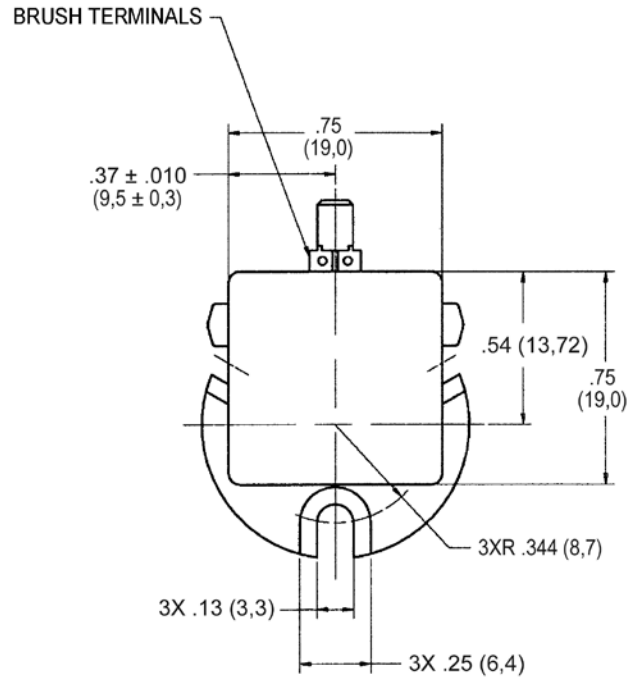
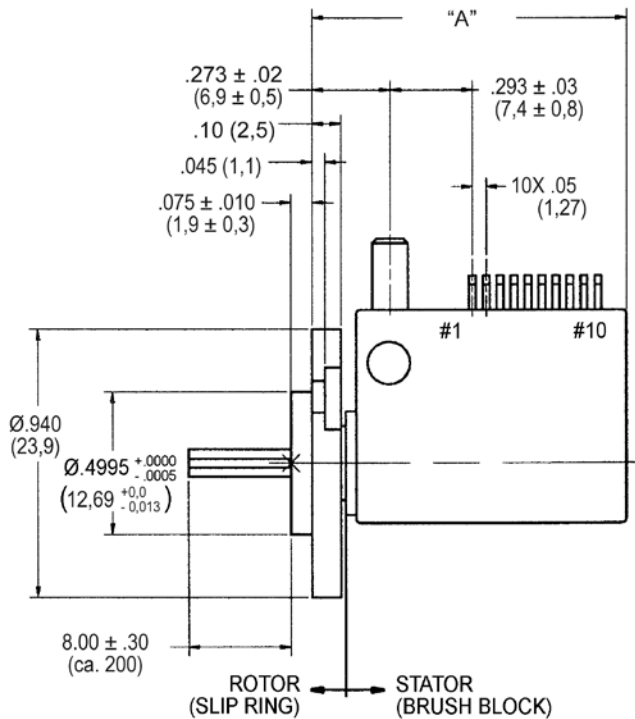
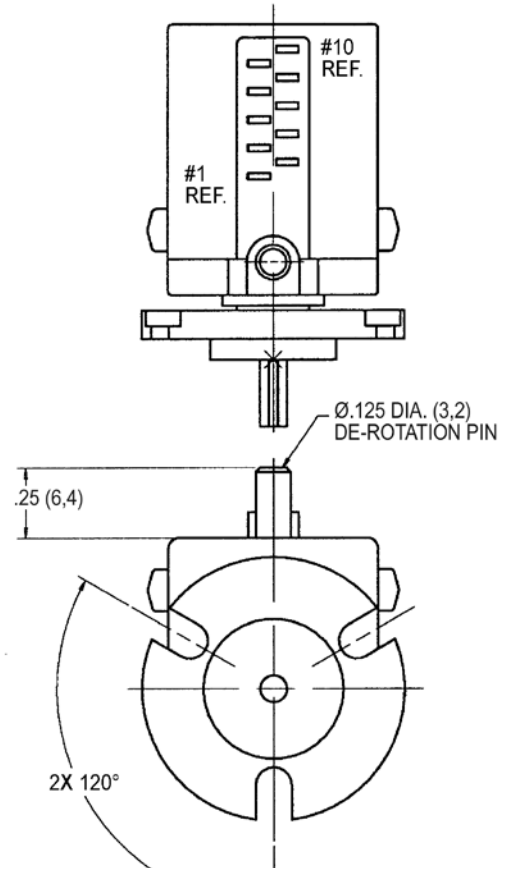

Dimensions in inches (millimeters)