

## FO215

### *Fiber optic rotary joint*

#### Description

The FO215 is an ultra-compact, two pass, multimode fiber optic rotary joint (FORJ). It is passive and bidirectional, and allows the transfer of optical signals on two separate optical fibers across rotational interfaces.

The FO215 can be combined with our electrical and fluid slip rings, giving a single, compact package for optical signals, electrical power and fluid transfer.

The FORJ can be assembled with pigtail lengths tailored to the customer's application. Housing, mounting flange and drive features can also be customized to meet the customer's requirements.

#### Features

- Provides rotary coupling for two multimode fibers
- Passive bidirectional device
- Can be combined with our electrical slips and fluid unions
- Connectorized version allows for easy fiber cable replacement
- Customized mounting flanges available
- Optional fluid-filled version for deep submergence to 10,000 psi (69,000 kPa)
- Can be integrated into existing slip ring designs
- Stainless steel housing (aluminum for connectorized version)
- Rugged design
  - MIL-STD-167-1 ship vibration
  - MIL-STD-810E functional shock (40 g)



#### Typical Applications

- Winches and cable reels for remotely operated vehicles
- Remote I / O in industrial machinery
- Video surveillance systems
- Material handling systems
- Sensor platforms
- Robots
- Turrets

# Fiber Optic Rotary Joints (FORJ)

FO215 Specifications			
Fiber Size (Microns):	50 / 125 or 62.5 / 125. Consult factory for other fiber types.		
Insertion Loss*		Typical	Maximum
	Channel 1	< 1.5 dB	< 3.0 dB
	Channel 2	< 4.5 dB	< 5.5 dB
Rotation Variation	Typical < 0.5 dB		Maximum < 1.0 dB
Back Reflection	Consult factory		
Wavelengths	850, 1300 or 1550 nm. Consult factory for other multi-wavelength applications.		
Rotational Speeds	To 500 rpm. Higher rotational speeds should be discussed with the factory.		
Temperature	-40 to +60 deg C (dry version) -20 to +60 deg C (wet version) Consult factory for extended range.		
Dispersion	< 10 ps (calculated)		
Exterior Surfaces	Stainless steel (aluminum for connectorized version)		
Vibration	Tested to MIL-STD-167-1 (ships)		
Shock	Tested to MIL-STD-810E		
Terminations	Standard is with pigtail cables terminated with ST connectors at each end. Alternative connectors types available (FC, SC, LC).		
Pressure	Up to 10000 psi (69,000 kPa) for fluid filled version**		
Pigtail Length	As required		

\*Add 0.5 - 1.0 dB to the insertion loss for connectorized version

\*\*Fluid filled version is slightly larger than shown below.

**Note:** Optical values given are based on use with LED sources.

## FO215 Dimensions

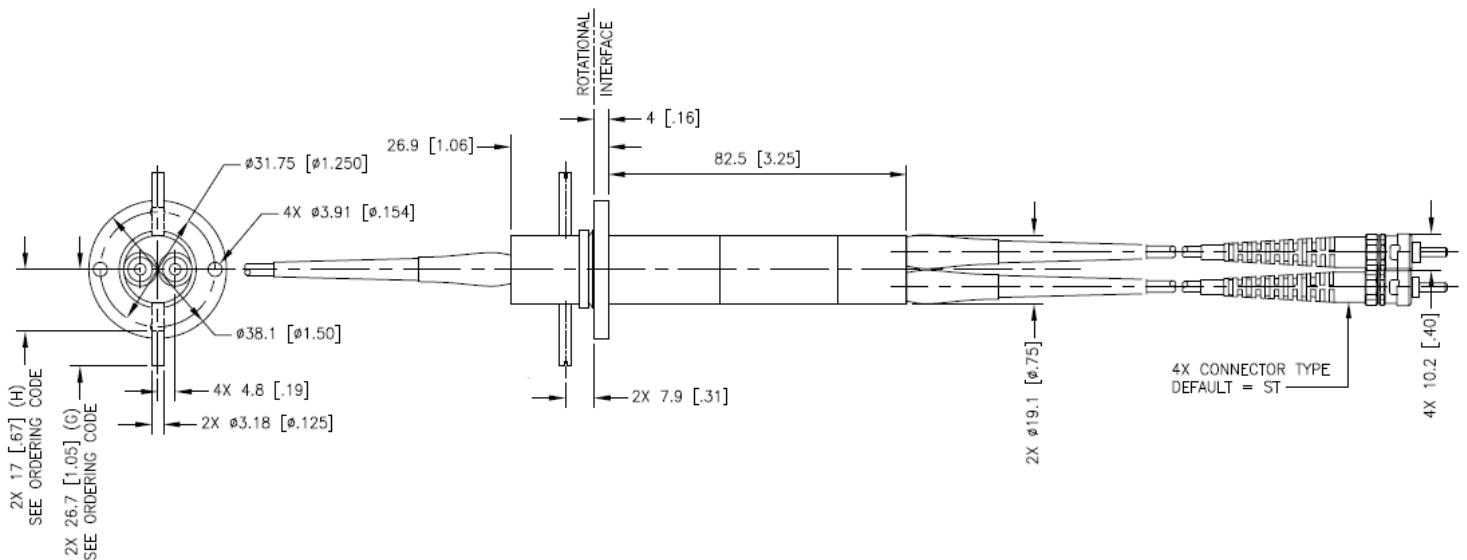

Dimensions in inches [millimeters]