

FO285 / FO286

Fiber optic rotary joint

Description

The FO285 (single-pass singlemode) and the FO286 (single-pass multimode) are passive and bidirectional, and allow the transfer of optical signals across rotational interfaces.

With a body diameter of only 9.5 mm and lengths of 26 mm and 19 mm for the FO285 and FO286 respectively, both units are ideally suited to applications where size and weight are critical issues. An extremely cost effective solution for high data rate signals, both models also offer other benefits of fiber optics, including low spark hazard and immunity to electromagnetic interference.

Both models can be combined with our electrical and fluid slip rings, and with our entire line of video and data multiplexers to provide a complete solution.

Features

- Provides rotary coupling for a multimode or singlemode fiber link
- Passive bidirectional device
- Low cost, small size
- Can be combined with our electrical slips and fluid unions
- Alternative drive coupling and mounting arrangements are available (consult factory for specification details)
- Can be integrated into existing slip ring designs
- Stainless steel or aluminum construction
- Rugged design
 - MIL-STD-167-1 ship vibration
 - MIL-STD-810F functional shock (40 g)
- 90° fiber exits available for limited space requirements



Typical Applications

- Unmanned ground vehicles
- Robots
- Surveillance systems
- Industrial automation
- Unmanned aerial vehicles and sub-systems

Fiber Optic Rotary Joints (FORJ)

Specifications				
	FO285 (Singlemode)		FO286 (Multimode)	
Fiber Size (Microns)	9 / 125 SMF-28 (consult factory for other sizes)		50 / 125 or 62.5 / 125 (consult factory for other sizes)	
Insertion Loss	Typical < 1.5 dB	Maximum < 3.5 dB	Typical < 1.5 dB	Maximum < 2.5 dB
Rotation Variation	Typical < 0.5 dB	Maximum < 1.5 dB	Typical < 0.5 dB	Maximum < 1.0 dB
Back Reflection*	Typical 22 dB	18 dB Minimum	Typical 22 dB	18 dB Minimum
Wavelength	1310 / 1550 nm (consult factory for other wavelengths)		850, 1300 or 1550 nm (consult factory for multi-wavelengths applications)	
Dimensions	9.5 mm diameter x 26 mm length		9.5 mm diameter x 19 mm length	
Weight/Material	Stainless steel: 16 g (pigtailed with connectors)		Aluminum: 7g, Stainless steel: 14 g (pigtailed with connectors)	
Rotational Speeds	To 1000 rpm. Higher rotational speeds should be discussed with the factory.			
Temperature	-55 to +75 deg C. Consult factory for extended range.			
Vibration	Tested to MIL-STD-167-1 (ships)			
Shock	Tested to MIL-STD-810F			
Terminations	Pigtailed with cable and connectors to meet customer's requirements 900 micron buffered cable standard			
Pigtail Length	As required			

*35 dB minimum back reflection option available for FO285.

FO285 and FO286 Dimensions

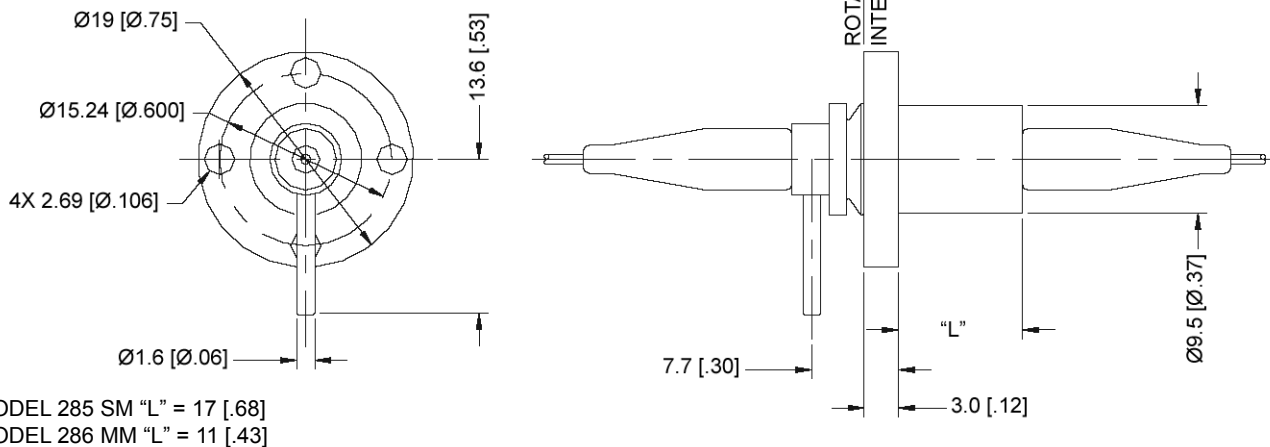

Dimensions in inches [millimeters]