

## M Series

### *Slip ring capsules*

#### Description

The M series of slip ring assemblies were developed for a wide variety of applications and environments. The M series is an ideal choice for limited space applications. As many as 120 separate circuits are accommodated in a 2.7 inch diameter OD envelope and in less than 5.50 inches long. These slip ring assemblies are a quick turn solution for your application. Off the shelf components allow for a delivery which meets your needs.

#### Features

- Ideal for limited space applications
- Modular construction for up to 120 circuits
- All circuits 60 V / 2 A each
- Continuous bidirectional rotation up to 1,000 rpm
- Dust-proof cover standard
- Flange mounting
- Superior signal quality
- 24 inch flying leads, optional wiring and harnessing available
- #26 AWG lead wire



#### Typical Applications

- Surveillance equipment

# Miniature Slip Ring Capsules

M Series Specifications		Options
Circuits	Up to 120 circuits: 2 A /60 volts	<ul style="list-style-type: none"> <li>• Longer leads</li> <li>• Special wiring</li> <li>• Fiber optic rotary joint</li> <li>• High voltage option to 120 V</li> </ul>
Maximum Speed	1000 RPM	
Terminals	#26 AWG flying leads	
Mounting	Flange mounting	

Number of Circuits	"L"
40	2.80
80	4.15
120	5.50

## M Series Dimensions

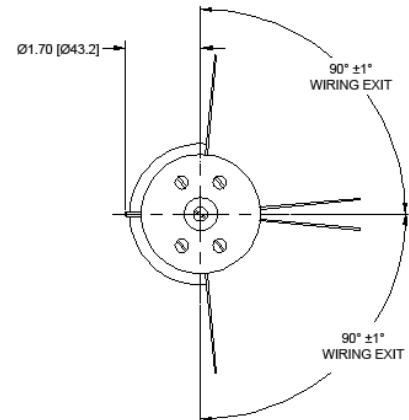
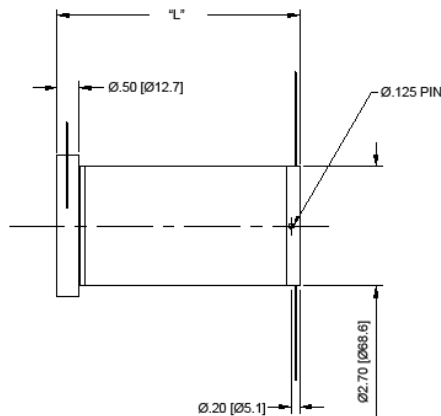
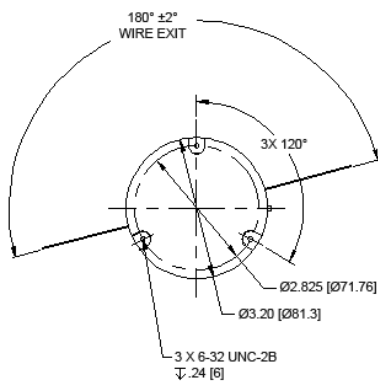

Dimensions in inches (millimeters)