

## High Performance Rotary Actuation Systems

Moog's line of Rotary Electro-Mechanical Actuators offer a product that is affordable, robust and designed to be compatible with a **Naval shipboard environment**. These actuator designs are based on Moog's product heritage in the aerospace, military and industrial markets. Product availability is as noted in the performance chart (see back) and can be readily customized to your specific application's needs.

Moog has the capability to design a solution to fit any Naval application. Actuators can be provided in **power ranges from fractional to over 100 horsepower**.

One of Moog's strengths is designing actuation systems requiring **precise motion control at high bandwidths**. Moog can provide the control systems engineering needed to tune the actuation system for optimal performance.

Additionally, Moog has designed and built rotary actuation systems for **undersea control surface and propulsion applications**. In these applications, the actuators are designed to withstand a lifetime of undersea exposure.



Moog has been designing **electro-mechanical actuation systems to replace hydraulic actuators** for over 25 years. *In many applications*, Moog can match the weight, center of gravity and envelop of the hydraulic actuator while improving system performance and reliability.

Moog is a leading provider of precision, high-performance control systems for military and commercial aircraft, satellites and space vehicles, launch vehicles, missiles, automated industrial machinery, medical equipment, and equipment on surface and undersea marine vessels. Moog's Naval rotary actuator is built upon 50 years of actuation system heritage. You can be assured that this actuator will allow your system to perform at its peak.

**Valve Actuation ■ Steering & Control Surface Actuation ■ Gun Pointing and Positioning  
Weapons Robots ■ Auto-Loader ■ Automation ■ Utility Actuation ■ Propulsion**



## Features and Customization Options

- Prime Mover Is a Permanent Magnet Synchronous Motor (Brushless DC). Induction or Stepper Motors Optional.
- Configured With Standard Internal Brake. Can Be Modified for Internal Clutch for Protection of Integrated Equipment.
- Telemetry Options Include Resolvers, Encoders, Potentiometers, RVDT or Hall Effect Devices.
- Can Be Provided With Integral Temperature, Current or Torque Sensors to Enable Health Monitoring.
- Optimized for Use With Moog's Digital Servo Motor Controller.
- Custom Rotary Actuators Can Be Provided to Meet Stringent Undersea Level Structure-borne Noise Requirements.
- Can Be Configured for Manual Operation.
- Can Be Designed to Withstand Water Immersion

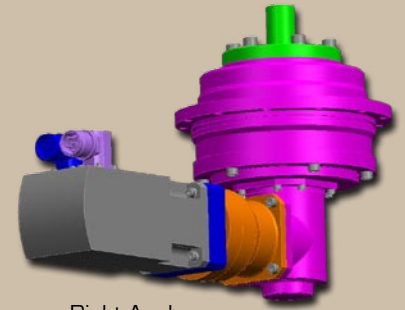

Right-Angle Configuration

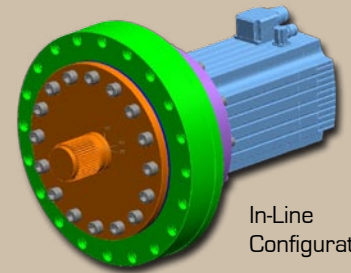

In-Line Configuration

## Key Naval Specifications

Ambient Temperature . . . . . -20°C to +70°C (Operating)

Explosion Proof . . . . . Mil-E-2036

Shock . . . . . Mil-Std-883C Grade B

Vibration . . . . . Mil-Std-167 Type I

Designed for exposure to Humidity, Driving Rain, Salt Fog & Spray, Sand & Dust, Solar Radiation and Corrosive Atmosphere

## ROTARY ACTUATION SYSTEMS PERFORMANCE CHART

Moog ICD Drawing	Type	Peak Drive Torque (ft-lbs)	Speed at Peak Torque (rpm)	Peak Power (Hp)	Height (in)	Width (in)	Length (in)	Weight (lbs)	Brake Holding Torque	Product Status
CA26346	Right-Angle	405	6	0.7	10	8	16	58	405 ft-lb	Preliminary Design
CA23488	In-Line	850	15	3.6	12	12	16	65	850 ft-lb	Preliminary Design
CA23489-001	In-Line	1407	15	6.0	12	12	16	114	1407 ft-lb	Preliminary Design
CA23489-002	In-Line	1840	15	7.8	12	12	18	120	1840 ft-lb	Preliminary Design
CA23490-001	In-Line	3044	15	12.9	14	14	20	248	3044 ft-lb	Preliminary Design
CA23490-002	In-Line	3399	15	14.4	14	14	22	262	6798 ft-lb	Preliminary Design
CA23491	In-Line	3990	15	16.9	12	12	18	378	3990 ft-lb	Preliminary Design
CA26339	In-Line	5300	10	14.8	17	17	22	503	5300 ft-lb	Preliminary Design