

Type 22 Antenna Pointing Assembly

The Type 22 antenna positioner assembly is a compact two-axis gimbal which is ideally suited for supporting and positioning small to medium sized spacecraft communications antennas. It is based on the Moog Type 2 rotary incremental actuator. The gimbal can be configured with either azimuth-elevation or X-Y (crossed axis) geometry, and several approaches to electrical cable management are available. Electrical cables can be carried across the gimbal axes in flexing loops, in cable wrap drums, or both. If an RF feed to the antenna is required, RF rotary joints can be integrated with the gimbal.

A variety of accessory devices is available for position feedback- potentiometers, optical encoders, or sine-cosine resolvers. Selecting a qualified unit in its existing configuration will have cost and schedule benefits; however, the modular construction of the gimbal facilitates substitutions and modifications to meet mission requirements. Options include launch latching mechanisms if the payload itself is not restrained at launch. Typical Type 22 gimbal performance specifications are shown in the table below. The unit can be driven by the standard Moog Electronic Control Unit, or customer electronics.



TYPE 22 ANTENNA POINTING ASSEMBLY

Specifications

	Data
Output Step Size	0.02 Degrees
Output Torque	>18 (N-m)
Unpowered Holding Torque	>15 (N-m)
Power Per Axis	15 W
Operating Temperature Range	-30° C to +65° C
Mass	5 Kg
Inertia Handling Capability	>12 Kg.m ²
Position Sensor	Potentiometer ±1.5 degree linearity

Antenna Pointing Assembly Dimensions

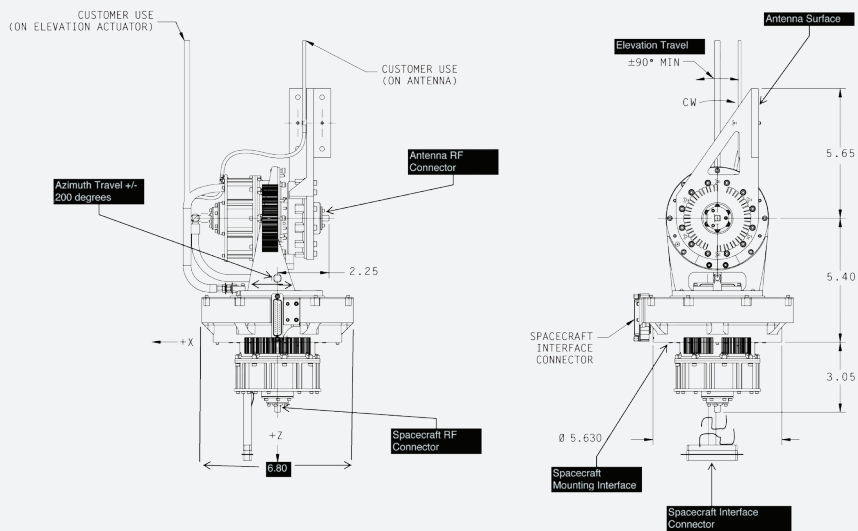

Heritage Programs

QUICKBIRD, GLAST, LEO

The small-angle rotary incremental actuator is a long-established product at Moog. The Type 2 actuator, which is near the lower end of the product line size spectrum, has become popular as the size of spacecraft and their systems has trended lower. The Type 2 actuator is widely used for both antenna positioning and solar array drives, both single axis and two-axis. Type 22 antenna positioner gimbals have been produced in both azimuth-elevation and cross-axis (X-Y) geometries. The large, load-capable output section of the actuators means that the gimbal design can be cantilever- no bearings other than the actuator output bearings are needed.

The heritage unit pictured is a typical compact, modular cantilever biax gimbal. Actuator output bearings have the load capability to carry all loads on the gimbal output, and the interaxis bracket which connects the two actuators is also designed to meet the load and stiffness requirements of the gimbal. Mission-specific design of the interaxis bracket also accommodates any special gimbal geometry requirements- axis spacing, output member offset, etc. The output bracket is configured to interface with the antenna. An RF path through the gimbal to the antenna is created by two RF rotary joints positioned on the actuator centerlines of rotation, and an interconnecting section of coaxial cable.

MOOG
SPACE AND DEFENSE GROUP

21339 Nordhoff Street, Chatsworth, California 91311 USA
+1.818.734.6700 Fax: +1.818.341.3884
www.moog.com