

Application Notes

1 Scope

These application notes are a guide to applying the G123-817-006 LVDT Oscillator Demodulator. The following is a summary of the process that these application notes apply to:

- Select the LVDT you will use.
- Determine the required oscillator level and frequency.
- Wire a test unit for performance checking.
- Optimise performance on the test unit by adjusting oscillator level, oscillator frequency, phase, output span and output zero.
- Apply your design.

The G123-817-006 is not a “plug and play” device. It needs to be carefully optimised for the particular LVDT being used.

LVDT selection criteria and closed loop considerations are not covered by these application notes.

2 Description

The G123-817-006 is a general purpose LVDT oscillator demodulator that can be configured to suit a wide variety of series opposed (4 wire) LVDTs. To produce optimum results, a knowledge of the characteristics of the LVDT being used is required.

For a more detailed description refer also to data sheet G123-817.

The G123-817-006 is an improved version of the G123-817-002. It does not have a 3.5/8.0V oscillator selector switch and has improved common mode noise rejection.

3 Installation

3.1 Placement

A horizontal DIN rail, mounted on the vertical rear surface of an industrial steel enclosure, is the intended method of mounting. The rail release clip of the G123-817-006 should face down, so the front panel and terminal identifications are readable and so the internal electronics receive a cooling airflow. An important consideration for the placement of the module is electro magnetic interference (EMI) from other equipment in the enclosure. For instance, VF and AC servo drives can produce high levels of EMI. Always check the EMC compliance of other equipment before placing the G123-817-006 close by.

3.2 Cooling

Vents in the top and bottom sides of the G123-817-006 case provide cooling for the electronics inside. These vents should be left clear. It is important to ensure that equipment below does not produce hot exhaust air that heats up the G123-817-006.

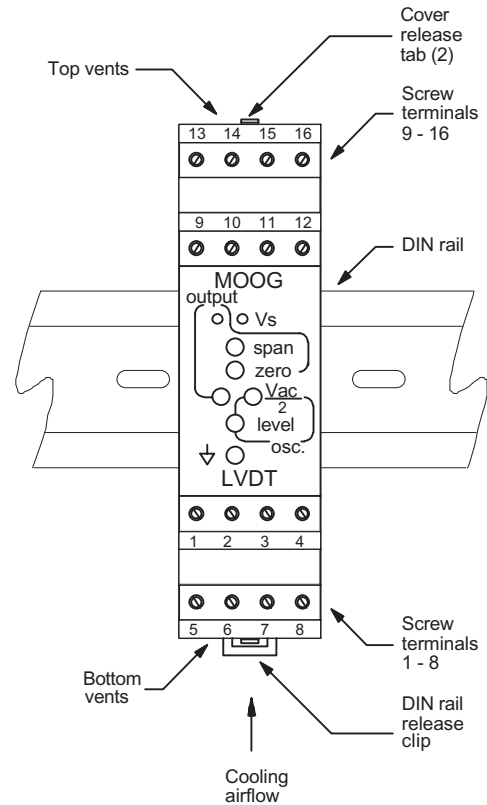

3.3 Wiring

The use of crimp “boot lace ferrules” is recommended for the screw terminals. Allow sufficient cable length so the circuit card can be withdrawn from its case with the wires still connected. This enables switch changes and pot adjustments on the circuit card to be made while the card is still connected and operating. An extra 100mm for cables going outside the enclosure, as well as for wires connecting to adjacent DIN rail units, is adequate. The LVDT cable should be 3 twisted pairs with an overall screen.

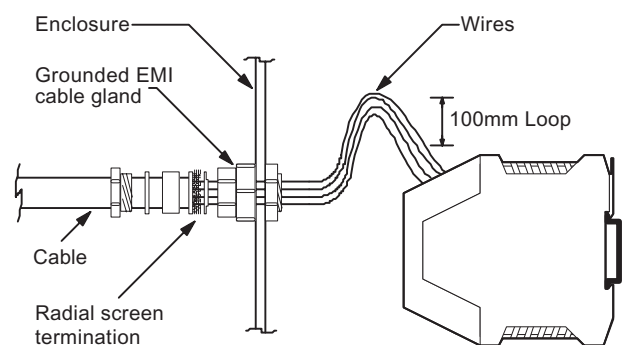

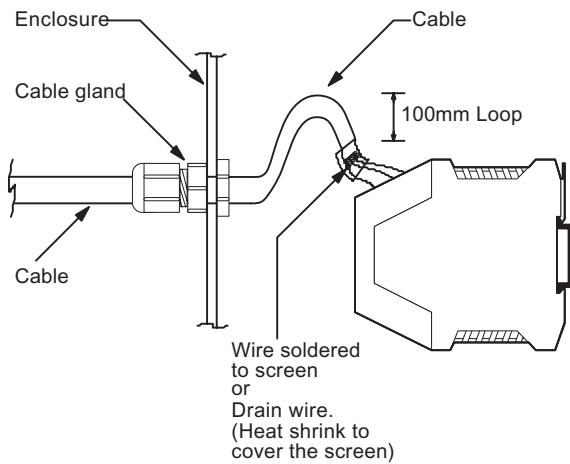

Alternative wiring

3.4 EMC

The G123-817 emits radiation well below the level called for in its CE mark test. Therefore, no special precautions are required for suppression of emissions. However, immunity from external interfering radiation is dependent on careful wiring techniques. The accepted method is to radially terminate the cable screens, in an appropriate grounded cable gland, at the point of entry into the industrial steel enclosure. If this is not possible, chassis ground screw terminals are provided on the G123-817-006. Exposed wires should be kept to a minimum length. Connect the screens at both ends of the cable to chassis ground.

4 Power supply

24V DC nominal, 22 to 28V

60mA @ 24V, without an LVDT connected

160mA @ 22V, with 50mA oscillator load

If an unregulated supply is used, the bottom of the ripple waveform is not to fall below 22V.

It is recommended that an M205, 250mA T (slow blow) fuse, compliant with IEC 127-2 sheet 3, be placed in series with the +24V input on terminal 1 to protect the electronic circuit.

5 Set-up adjustments

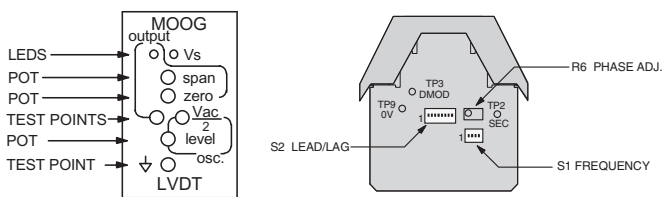

Slide S1 and S2 up to turn on.

Front panel potentiometers are 15 turns.

Bold test refers to front panel controls.

Italic test refers to circuit card controls.

Default shipping frequency is 3.1KHz.

Default shipping phase adjustment is zero.

5.1 Excitation frequency

Select the manufacturer's recommended "zero phase" excitation frequency with the internal *frequency select* switches. The circuit card will need to be withdrawn from the case to do this. See paragraph six. If the recommended frequency is not known, start off with 3.1KHz, the default setting. This is a good starting point because it is an order of

Frequency selection, ✓ = switch on

S1-1	S1-2	S1-3	S1-4	f, kHz
	✓	✓	✓	0.8
✓		✓	✓	1.7
		✓	✓	2.5
✓	✓		✓	3.0
	✓		✓	3.9
✓			✓	4.7
✓	✓	✓		5.1
			✓	5.5
	✓	✓		5.9
✓		✓		6.8
		✓		7.6
✓	✓			8.1
	✓			8.9
✓				9.7
				10.5

magnitude greater than the 300Hz electronic bandwidth pre-set on the circuit card and enables the mechanical bandwidth to match the electronic bandwidth. Initially, do not select any phase adjustment. Connect a dual trace oscilloscope to front panel test point $\frac{Vac}{2}$ and circuit card TP2. Set an oscillator level

with the front panel **level** pot so that the signals are free of noise and ripple, so a clear, easily read signal is displayed. Ensure that the level is not so high as to distort the waveform. Select other frequencies with the *frequency select* switches to see if a minimum phase difference can be achieved. Select the frequency that gives a minimum phase difference. Be aware that there is an adjustment on the circuit card that reduces the phase difference so it is not essential to achieve exactly zero phase difference. Do not turn on all four switches together. This is an invalid selection.

5.2 Excitation oscillator level

Set the LVDT manufacturer's recommended excitation oscillator level with the front panel **level** pot. The $\frac{Vac}{2}$ test point gives

half of the actual level i.e. 2.5V on the test point is equal to a true 5.0V on the LVDT primary.

The excitation oscillator level is set by the front panel **osc.** (oscillator) **level** potentiometer. Note that the maximum permissible primary voltage is 8.0V RMS. Increasing the oscillator level will not increase the output. See 5.5.

Do not set the **oscillator level** greater than 8.0V RMS. The maximum permissible LVDT full scale sensitivity is 0.9V/V. Full scale sensitivity is defined as the secondary voltage per volt of primary voltage excitation, when the LVDT core is at full stroke. With 8.0V RMS osc. voltage the secondary voltage input to the G123-817-006 must not exceed 7.2V RMS, when the LVDT core is at full stroke.

There are two limits on the maximum permissible secondary voltage

- An absolute maximum of 8.0V RMS
- 0.9 times the osc. voltage.

When setting the **oscillator level** for the first time it is advisable to observe the oscillator waveform on the $\frac{Vac}{2}$ test

point, with an oscilloscope. For correct operation the waveform should be a clean sinusoid. Maximum output current is 50mA RMS. If the waveform is distorted, reduce the level until a clean sinusoid is observed.

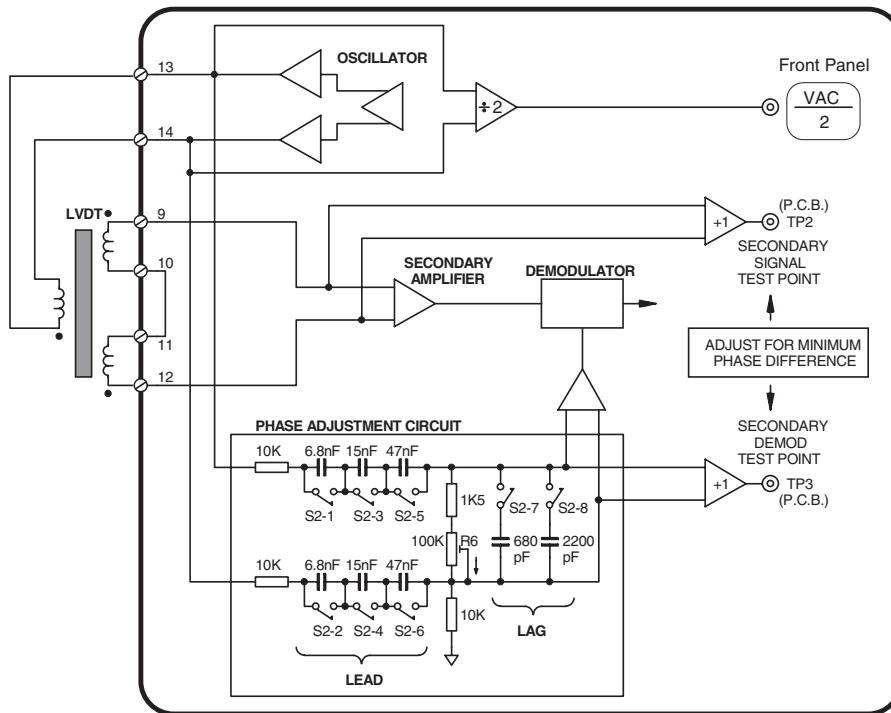

Phase adjustment circuit

Example:

Apply the Schaevitz 4000HR LVDT. It has a stroke of $\pm 100\text{mm}$ and a sensitivity of 8.8mV/V/mm .

At full stroke of 100mm this equates to a sensitivity of 0.88V/V .

The manufacturer's recommended excitation is 3.0VRMS at 2.5kHz .

Adjust the osc. level pot so the output is 3.0V RMS

($\frac{\text{Vac}}{2} = 1.5\text{V RMS}$). The full scale secondary voltage will be

$3 \times 0.88 = 2.64\text{V RMS}$, just below the secondary maximum of $0.9 \times 3.0 = 2.70\text{VRMS}$.

If the oscillator level is set to 8.0V RMS , the full stroke secondary level would be $0.88 \times 8 = 7.04\text{V RMS}$. This is less than the secondary maximum of 7.2VRMS and the absolute maximum of 8.0VRMS , so the oscillator level can be safely set up to the maximum of 8.0V RMS .

5.3 Secondary phase difference

The G123-817-006 circuit uses the primary signal to synchronously detect the secondary signal. Phase differences between these signals can cause minor errors and so there is the facility on the circuit card to null phase differences.

Withdraw the circuit card from its case and connect a dual channel oscilloscope to primary TP $\frac{\text{Vac}}{2}$ and secondary TP2.

Move the LVDT core until TP2 has a signal that is noise free and easy to read. The signal will be too small near null. Determine if the secondary is leading or lagging the primary signal. Select lead or lag. Do not select lag and lead together. Now monitor the secondary TP2 and the phase adjusted secondary demod signal on TP3. Adjust the phase pot R6 until these two signals are in phase. Select the appropriate lag or lead capacitors to enable the best phase match. Note that R6 is a 25 turn pot.

Switches S2-7 and S2-8 select the two lag capacitors, which are switched in parallel. Switches S2-1 to S2-3 and S2-4 to S2-6 select the lead capacitors, which are switched in series. To maintain a balanced circuit the switches should be paired in the same positions. The pairs are 1 and 2, 3 and 4, 5 and 6.

The minimum phase angle varies with frequency and is typically 3° to 8° . If the phase error is less than 3° to 8° , it cannot be reduced and so no phase adjustment may give the minimum phase error.

5.4 Output zero

Move the LVDT core to its required centre position and adjust the front panel **zero** pot. until the level on the **output** test point is 0V . Set to 12mA if using the $4\text{-}20\text{mA}$ signal output.

5.5 Output span

Move the LVDT core to its required full stroke position and adjust the front panel **span** pot until the level on the **output** test point is 10V . If the polarity is opposite to that required, interchange the secondary wires on terminals 9 and 12. Re-check the **zero** setting. Increasing the **oscillator level** will not increase the output. If 10V output cannot be achieved, consult Moog. Double check the waveform distortion to ensure the oscillator is not over loaded. Set to 20mA if using the $4\text{-}20\text{mA}$ signal output.

6 Withdrawing the circuit card from its case

In order to set the oscillator frequency, select phase lag or lead, or to adjust the phase angle, the circuit card needs to be withdrawn from its case.

To do this, push one tab in with a pen or screwdriver while gently pulling on the top cover on that side. The cover will release approximately one mm. Repeat on the other side and withdraw the cover and circuit card until the required adjustment points are exposed. The rigidity of the connecting wires will hold the circuit card in position while adjustments are made.

7 Block-wiring diagram

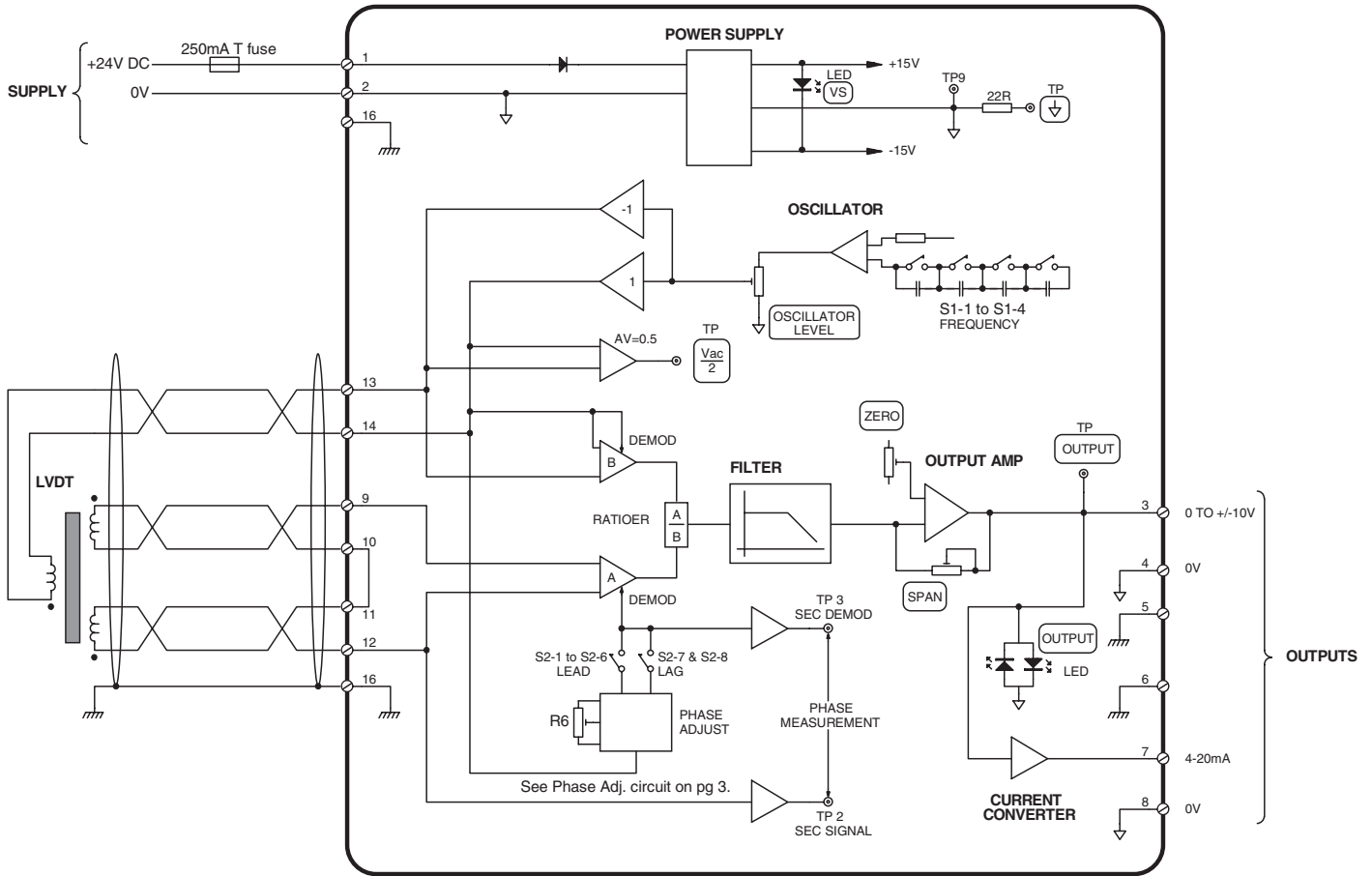

8 Specifications

Outputs: 0 to $\pm 10V$, 1 kOhm min load, terminal 3
4-20mA, 500 Ohm max load, terminal 7
100 PPM/dB excitation rejection
500PPM non-linearity
4mV RMS ripple max @ 3kHz
300Hz bandwidth

Oscillator: 1 to 8.0V RMS
1 to 10kHz
50mA RMS
-50dB THD
200 PPM/°C frequency TC

Maximum allowable secondary voltage: Terminals 9 and 12
0.9 x osc. voltage or 8.0V RMS

Front panel indicators: Output positive = red
negative = green
Vs, internal supply = green

Front panel test points: Output $\pm 10V$
oscillator Vac, half level
2

Front panel trim pots: Output span
Output zero
Oscillator level

Full scale sensitivity: Min: 0.15 V/V
Max: 0.9 V/V

Internal trim pot: Secondary demodulator phase adjust R6

Internal switches: Oscillator frequency select S1-1 to -4
Phase lead select S2-1 to -6
Phase lag select S2-7 and -8

Supply: Terminal 1
24V DC nominal, 22 to 28V
60mA @ 24V, no load
160mA @ 22V, with 50mA oscillator load

Recommended supply protection: M205, 250mA T (slow blow) fuse compliant with IEC 127-2 sheet 3

Mounting: DIN rail
IP 20

Temperature: 0 to +40°C

Dimensions: 100W x 108H x 22.5D

Weight: 127g

CE mark: EU 2011/65/EU RoHS
EU 2014/30/EU EMC
EN61000-6-4 : 2007 emission
EN61000-6-2 : 2005 immunity

RCM: EN61000-6-4 : 2007 emission

Internet Data

For a detailed Data Sheet and the latest version of this Application Note please refer to the Moog website www.moog.com/industrial

MOOG

Industrial Controls Division. Moog Inc., East Aurora, NY 14052-0018. Telephone: 716/687-4954. Fax: 716/655-1803. Toll Free 1-800-272-MOOG.

Moog GmbH. Germany. Telephone: 07031-622-0. Fax: 07031-622-100.

Moog Sarl. France. Telephone: 01 45 60 70 00. Fax: 01 45 60 70 01.

Moog Australia Pty. Ltd. Telephone: 03 9561 6044. Fax: 03 9562 0246.

Moog pursues a policy of continuous development and reserves the right to alter designs and specifications without prior notice. Information contained herein is for guidance only and does not form part of a contract.
Australia: Melbourne, Sydney ■ Austria: Vienna ■ Brazil: São Paulo ■ Denmark: Birkerød ■ England: Tewkesbury ■ Finland: Espoo ■ France: Rungis ■ Germany: Böblingen, Dusseldorf ■ Hong Kong: Shatin ■ India: Bangalore
Ireland: Ringaskiddy ■ Italy: Malnate (VA) ■ Japan: Hiratsuka ■ Korea: Kwangju-Kun ■ Philippines: Baguio City ■ Singapore: Singapore ■ Sweden: Askim ■ USA: East Aurora (NY)