

G122-828B017 Velocity and Pressure (VP) Controller

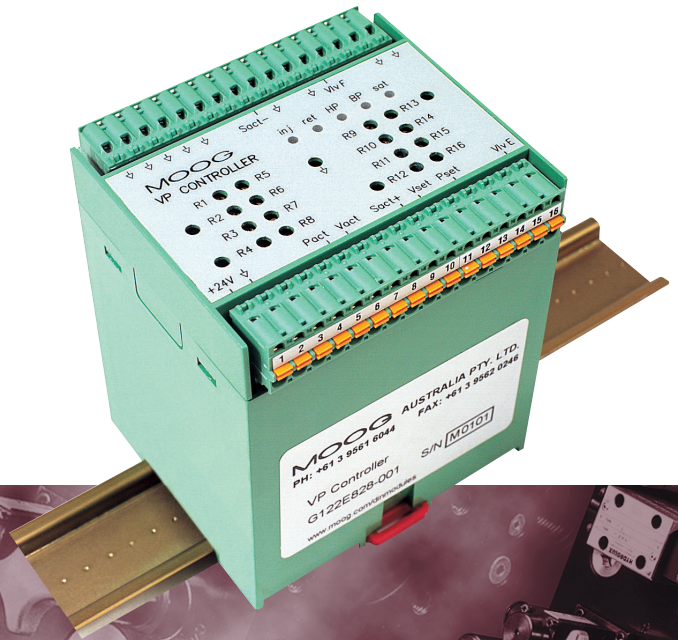

DESCRIPTION

The Moog G122-828B017 VP Controller, combined with a Moog servo valve, a position or velocity transducer and a pressure transducer, will provide closed loop control of the injection cycle of a plastic injection molding machine.

The functions controlled during the cycle are:

- Injection speed
- Injection pressure limiting
- Hold pressure during setting
- Back pressure during plasticising

Retract speed during decompression is controlled open loop.

Closed loop control of the critical injection speed and pressures ensures precise repeatability of mold fill and so consistent and high quality machine output. Variations in material characteristics, machine hydraulic pressure, mold temperature, screw clearances, etc, do not result in the normally observed variations in part quality. Consistent and repeatable inject speed, hold pressure and back pressure dramatically reduce the influence of these variables.

The VP Controller is housed in a compact DIN rail mounting enclosure and requires a 24V DC supply.

FEATURES

- Improved yield
- Higher quality parts
- Set once, no further adjustments needed
- Low cost
- Moog quality and reliability
- Compact DIN rail housing
- Convenient front panel controls, test points and indicators
- CE marked

Rev C of this data sheet changes the model number to B017 and adds a power supply fuse. The B017 is functionally identical to the A017.

The A017 and B017 models differ from the -017 model in that the valve drive during back pressure is limited to +5 V maximum in the A017 and B017 models. The -017 model allowed full +10 V valve drive.

SPECIFICATIONS

Logic inputs: Inject, hold pressure, back pressure and retract

- On at 10 V
- Off at 5 V
- Max 28 V
- 5.1 mA @ 24 V

Valve output: 0 to ± 10 V @ ± 2 mA max

- Short circuit and over voltage protected

Monitor signal outputs:

- S-act+ 0 to +10 V
- S-act – 0 to –10 V
- P-act 0 to +10 V
- V-act 0 to +10 V
- 2mA max, short circuit and over-voltage protected

Front panel test points:

- Wipers of R2, 4, 12 & 13 and 0 V reference

Front panel indicators:

- inj (inject) – green
- HP (hold pressure) – green
- BP (back pressure) – green
- ret (retract) – green
- sat (valve saturated) – yellow

Front panel trim pots:

- | | |
|--------------------------------|-----------------------------|
| R1 velocity sensitivity | R9 hold pressure I gain |
| R2 actual pressure zero | R10 back pressure P gain |
| R3 actual pressure sensitivity | R11 back pressure I gain |
| R4 hold pressure zero | R12 back pressure zero |
| R5 hold pressure balance | R13 retract adjust |
| R6 voltage distributor P gain | R14 integral delay time |
| R7 voltage distributor I gain | R15 pressure limiter P gain |
| R8 hold pressure P gain | R16 pressure limiter I gain |

P-set signal input:

Rin = 100 kOhm

Pin 13

Vin = 0 to +10 V

V-set signal input:

Rin = 10 kOhm

Pin 11

Vin = 0 to +10 V

P-act signal input:

Rin = 15 kOhm

Pin 4

Vin = 0 to +100 mV

S-act signal input:

J404 made

Pin 8, voltage

Rin = 100 kOhm

Vin = +10 to 0 V

Vin must decrease during injection

V-act signal input:

J421 made

Pin 8, frequency

full scale = 1.8 kHz
mark space ratio = 50%
Rin = 2 kOhm pull up to +15 V

S-act signal input:

Pin 9

Rin = 100 kOhm

Vin = –10 to 0 V

Pressure transducer: +5 V ± 0.25 V @ 50 mA max supply, Pin 3

Valve supply:

Internally supplied from pin 1

Pin 20

300 mA max output

Supply:

24V nominal, 22 to 28 V

130 mA @ 24 V, sat LED on

Fuse 250 mA T, slow blow,

compliant to IEC127-2 sheet 3

Mounting:

DIN rail to EN50002

Housing IP40

Terminal block IP20

Temperature:

0 to +40°C

Dimensions:

90 L x 85 W x 108 H

Weight:

316 gm

CE mark:

EU 2011/65/EU RoHS

EU 2014/30/EU EMC

EN61000-6-4 : 2007 emission

EN61000-6-2 : 2005 immunity

EN61000-6-4 : 2007 emission

RCM:

EN61000-6-4 : 2007 emission

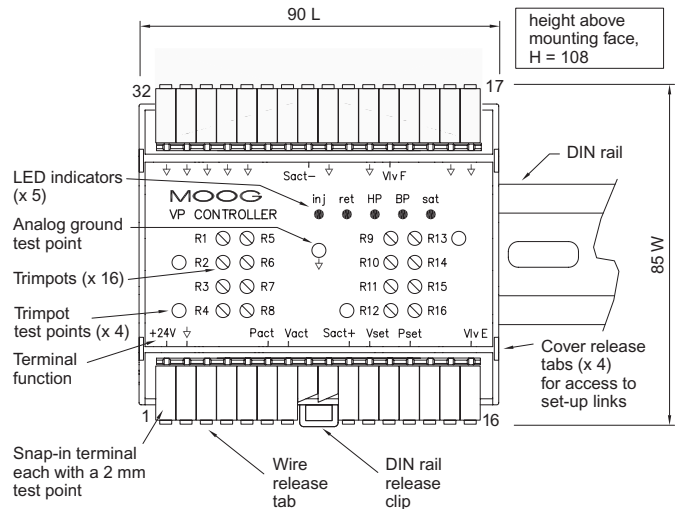

CYCLE DESCRIPTION

Refer to the timing diagram below and the Operating detail drawings on page 4.

Inject: At the start of the cycle the machine PLC sets the INJECT logic input true and outputs an analog voltage V-set, to set the inject speed. It also outputs an analog voltage P-set, which sets the upper limit of the inject pressure. As soon as the actual inject pressure reaches the P-set value, the speed control is suppressed by the pressure control and the rest of the inject part of the cycle is at constant pressure. The pressure will normally rise to this limit when the mold is full and the inject actuator can no longer move forward.

Hold Pressure: This part of the cycle maintains a constant pressure on the part, setting in the mold. The machine PLC now removes the INJECT logic input and sets HOLD PRESSURE true. At the same time it adjusts the P-set analog value to the required hold pressure.

Back Pressure: This part of the cycle maintains a constant pressure in the rear of the injection actuator to ensure even plasticising.

The machine PLC removes the HOLD PRESSURE logic signal and sets the BACK PRESSURE logic signal true. It adjusts the P-set analog signal to the required pressure and the closed loop holds the oil pressure at that value as the screw rotates and forces the inject actuator back.

Retract: After plasticising, the screw is pulled back to stop inject nozzle drool.

The machine PLC removes the BACK PRESSURE logic signal and sets the RETRACT logic signal true. The machine also pressurises the front of the inject actuator to pull back the screw. Oil flow out of the back of the actuator is controlled open loop by the servo valve. The command to the servo valve can come from V-set, or R13 on the VP Controller, or both.

CYCLE TIMING DIAGRAM

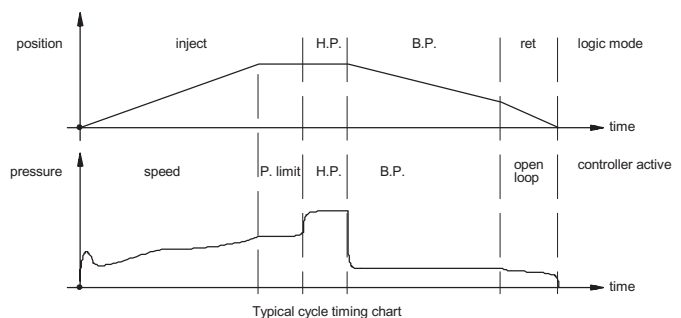

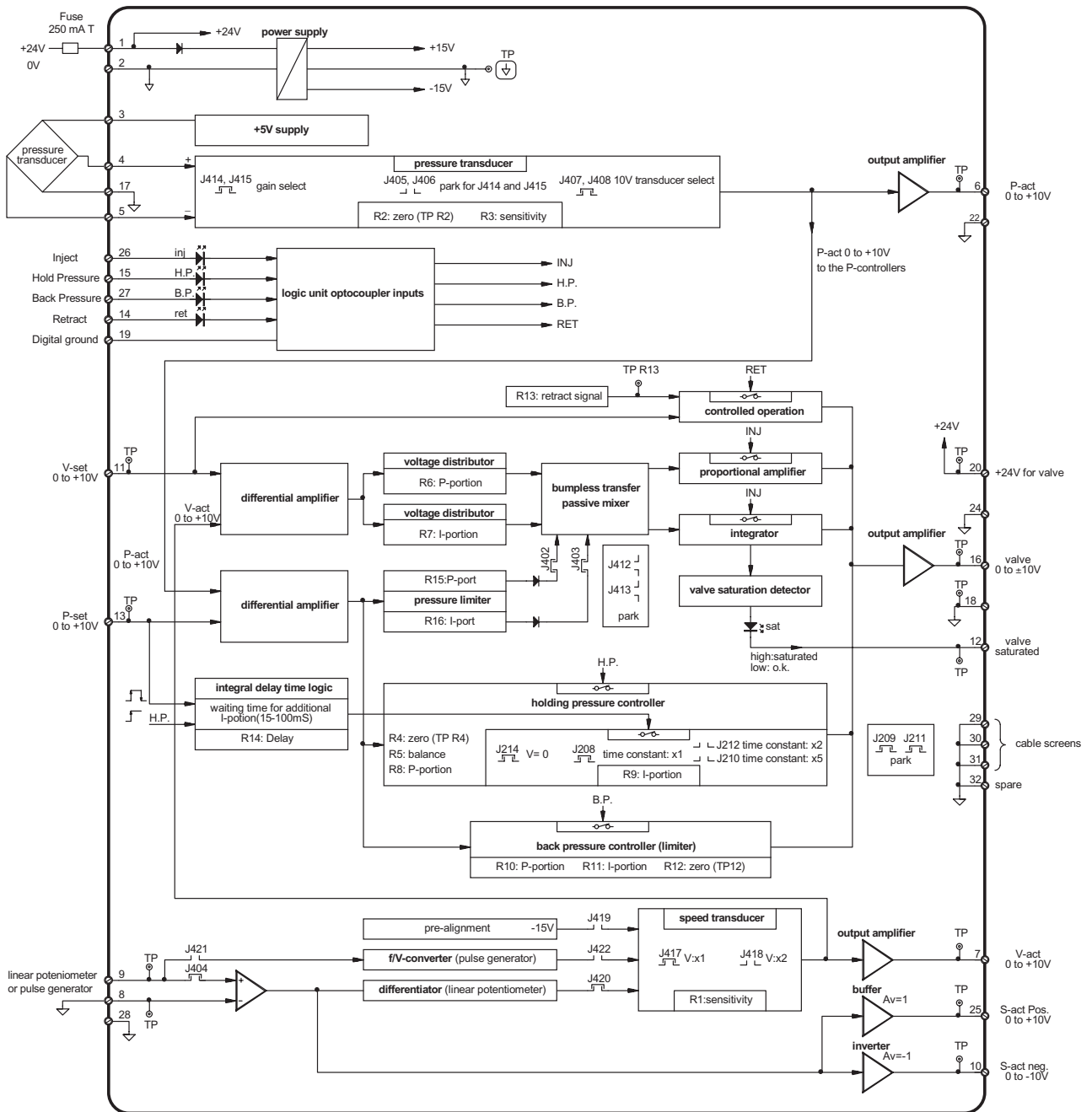

MAIN PCB 3 TOP

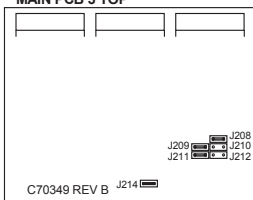

Default link loaded.

Link	Default	Function
J208	<input checked="" type="checkbox"/>	Hold pressure controller integrating capacitor 470nF
J209	<input checked="" type="checkbox"/>	Park for J210
J210	<input type="checkbox"/>	Hold pressure controller integrating capacitor 100nF
J211	<input checked="" type="checkbox"/>	Park for J212
J212	<input type="checkbox"/>	Hold pressure controller integrating capacitor 220nF
J214	<input checked="" type="checkbox"/>	Hold pressure controller integrator dissable

MAIN PCB 4 BOTTOM

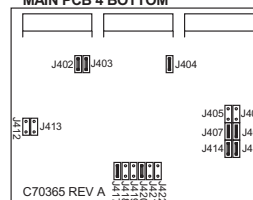

Default link loaded.

Link	Default	Function
J402	<input checked="" type="checkbox"/>	Pressure limiter P enable
J403	<input checked="" type="checkbox"/>	Pressure limiter I enable
J404	<input checked="" type="checkbox"/>	Velocity signal from linear pot
J405	<input type="checkbox"/>	Park for J414
J406	<input type="checkbox"/>	Park for J415
J407	<input checked="" type="checkbox"/>	Pressure measuring amp 10V transducer
J408	<input checked="" type="checkbox"/>	Pressure measuring amp 10V transducer
J412	<input type="checkbox"/>	Park for J402
J413	<input type="checkbox"/>	Park for J403
J414	<input checked="" type="checkbox"/>	Pressure measuring amp gain select
J415	<input checked="" type="checkbox"/>	Pressure measuring amp gain select
J417	<input checked="" type="checkbox"/>	Velocity measuring amp low gain Vx1
J418	<input type="checkbox"/>	Velocity measuring amp high gain Vx2
J419	<input type="checkbox"/>	Velocity signal offset
J420	<input checked="" type="checkbox"/>	Velocity signal from linear pot
J421	<input type="checkbox"/>	Velocity signal from pulse pick up
J422	<input checked="" type="checkbox"/>	Velocity signal from pulse pick up

LINK ACCESS

Access to the internal circuit boards, so the links can be set, is achieved by the following:

- Remove both electrical connectors.
- Using a medium sized, flat blade screw driver, push in one side tab while pulling the cover away from the base. The cover will click over the tab.
- Repeat for the other tab on that side.
- After the two tabs on one side are released, release the two tabs on the other side.
- Withdraw the electronics assembly and identify the circuit boards by their part numbers C70349 and C70365.

INTERCONNECT DIAGRAM

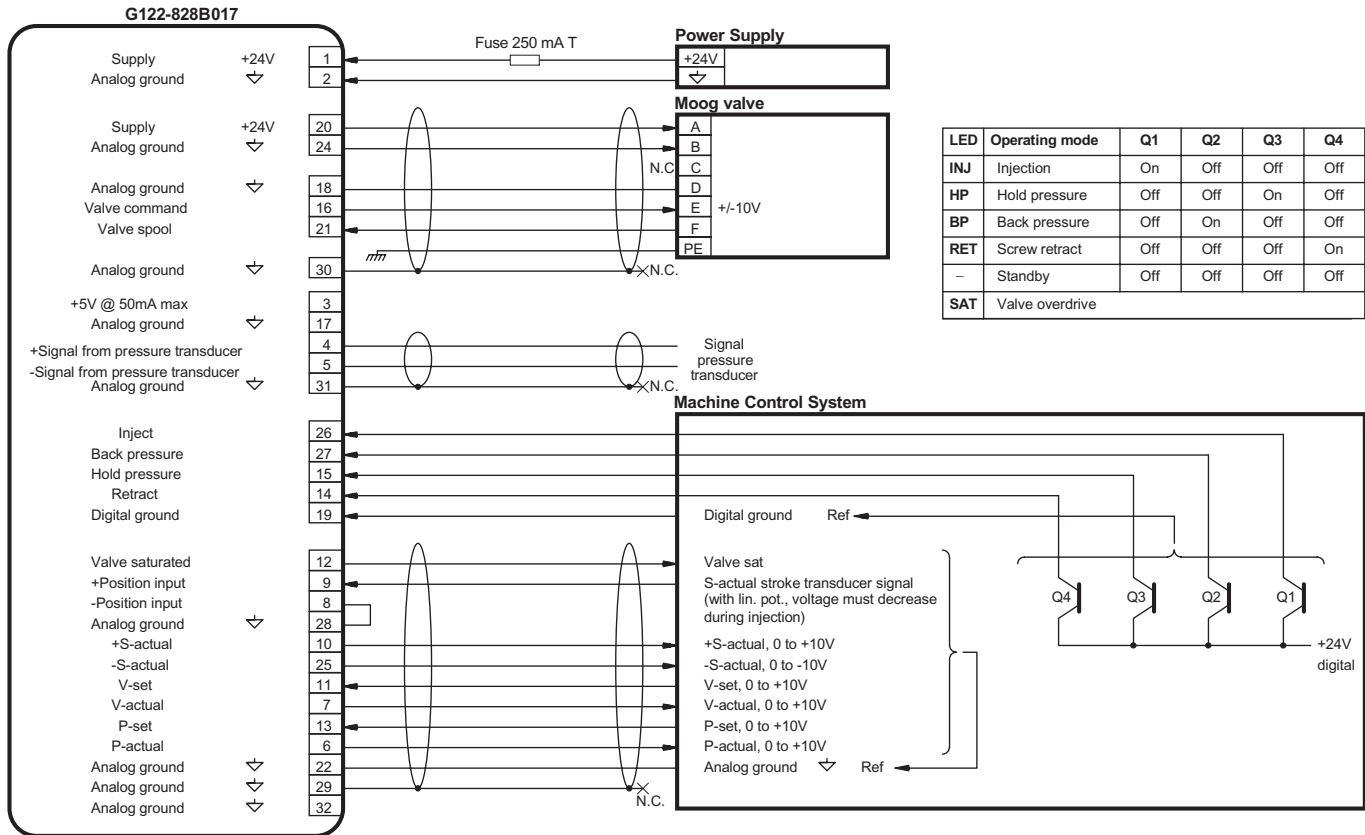

FRONT PANEL TEST POINTS

Location	Name	Description
R2	-	Actual pressure zero
R4	-	Hold pressure command zero
R12	-	Back pressure command zero
R14	-	Retract speed trim
Terminal 6	Pact	Actual inject pressure. 0 to +10V
Terminal 7	Vact	Actual inject velocity. 0 to +10V
Terminal 10	Sact+	Actual inject position. 0 to +10V
Terminal 11	Vset	Command (set) inject velocity
Terminal 13	Pset	Command (set) inject pressure
Terminal 16	Vlv E	Servo valve drive signal. 0 to ±10V
Terminal 21	Vlv F	Servo valve spool signal. Varies with valve model.
Terminal 25	Sact-	Actual inject position. 0 to -10V
Various	⏚	Signal 0V reference (ground)

ORDERING INFORMATION

G122-828B017 VP Controller

MOOG

Moog Australia Pty. Ltd. 18 Corporate Drive, Heatherton, Victoria 3202, Australia. Telephone: 03 9561 6044. Fax: 03 9562 0246.
 Industrial Controls Division. Moog Inc., East Aurora, NY 14052-0018. Telephone: 716/687-4954. Fax: 716/655-1803. Toll Free 1-800-272-MOOG.
 Moog GmbH. Hanns-Klemm-Strasse 28, 71034 Böblingen, Germany. Telephone: 07031-622-0. Fax: 07031-622-100.
 Moog Japan Ltd. 1-8-37 Nishisindo, Hiratsuka, Kanagawa, Japan 254-0019. Telephone: 81 463 55 3615. Fax: 81 463 54 4709.

For the location nearest you, contact: www.moog.com/worldwide.

Moog pursues a policy of continuous development and reserves the right to alter designs and specifications without prior notice. Information contained herein is for guidance only and does not form part of a contract.

Australia: Melbourne, Sydney ■ Austria: Vienna ■ Brazil: São Paulo ■ Denmark: Birkerød ■ England: Tewkesbury ■ Finland: Espoo ■ France: Rungis ■ Germany: Böblingen, Dusseldorf ■ Hong Kong: Shatin
 India: Bangalore ■ Ireland: Ringaskiddy ■ Italy: Malnate (VA) ■ Japan: Hiratsuka ■ Korea: Kwangju-Kun ■ Philippines: Baguio City ■ Singapore: Singapore ■ Sweden: Askim ■ USA: East Aurora (NY)

INTERNET DATA

For the latest version of this Data Sheet please refer to the Moog website www.moog.com/industrial