

32 SERIES MICRO SERVO VALVES

Responsive valve in a compact package

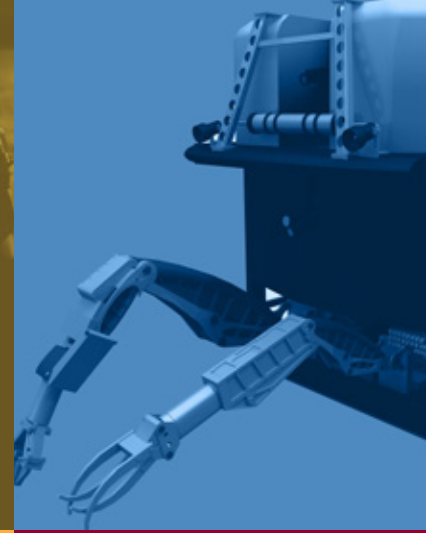

The 32 Series is a two-stage, flow control, double-nozzle, mechanical feedback servo valve that has a stainless steel body and integrated torque motor in an environmentally sealed compartment. Its nozzle-flapper design is a proven technology for applications where high response, stability and accuracy are required in a compact package. As the higher flow counterpart to the 30 series it has an impressive power density of nearly 1.5 horsepower per oz. equivalent, or 18.6 horsepower overall. Many options are available for this series including vented and non-vented motor caps, pigtail versions for convenient installation, tie wire options and special connectors.

The 32 Series Servo Valve is designed to perform reliably over a long service life even in potentially extreme environments where temperatures might drop to -20 °F (-28.9 °C) or be as high as 400 °F (204.4 °C). The aluminum body and self contained envelope provides rugged construction which also allows for use in environments with potentially high acceleration, and or be exposed to high shock and vibration. This product is part of our Micro-hydraulic offering which delivers high power to weight ratio and high efficiency. It achieves this all while delivering high dynamics and precise flow control for better overall system control.

ADVANTAGES

- High response improves control capability
- Compact light weight package for mobile applications
- Rugged construction designed for extreme conditions

APPLICATIONS

- AGV/ROV
- Animatronics
- Manipulators
- Downhole Tools
- Entertainment
- Robotics for Unstructured Environments
- Human-Scale Robotics
- Mobile Robotics including Construction
- Collaborative Robotics
- Quadrupeds
- Humanoid
- Biomimetic
- Exo-Skeletons
- Haptics
- Virtual Reality, Simulation and Training
- Autonomous Vehicles

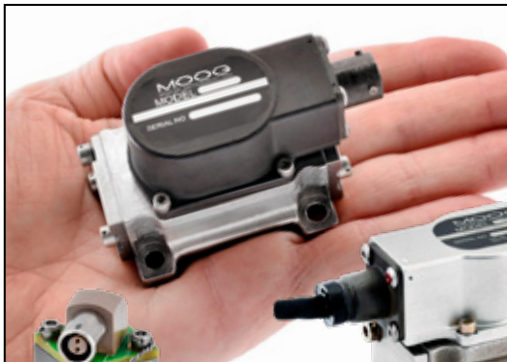

Wire direct version for convenient installation and space saving



Many specialized versions available including tie wire options and special connectors



Micro-hydraulics are ideal for applications requiring high power density

RESPONSE PLOT

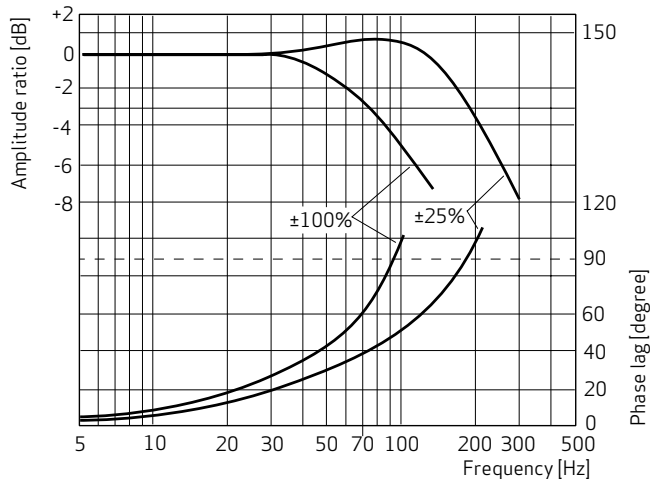

Typical Responses for Peak Sinusoidal Inputs of $\pm 25\%$ and $\pm 100\%$ Rated Current

Supply 210 bar (3,000 psi)

Oil Temp 38°C (100°F)

PERFORMANCE CURVE

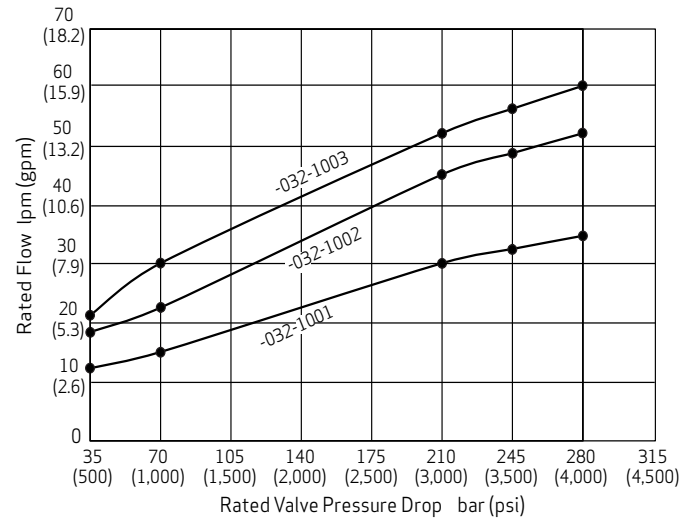

DYNAMIC TECHNICAL SPECIFICATIONS

Frequency of 90 deg phase (3,000 psi)	> 160 Hz
Step Response	4.5 ms
Amplitude Ratio	< 2 db
First Order Time Constant	0.0020 sec
2nd Order Natural Frequency	160 Hz
Damping Ratio	0.55

GENERAL TECHNICAL SPECIFICATIONS

Weight	370 g (13 oz)
Maximum Operating Pressure	275 bar (4,000 psi)
Rated Flow	15.0 to 30.0 l/min (4.0 to 8.0 gpm) @ Δp 70 bar (1,000 psi)
Mounting Pattern	0.78 in. port circle [ISO 10372-03-03-0-92]
Static Performance	
Rated Flow Tolerance	$\pm 10\%$
Linearity	< $\pm 7\%$
Null Region	< $\pm 3\%$
Null Bias	< $\pm 3\%$ initial; < $\pm 5\%$ long term
Hysteresis	< $\pm 3\%$
Threshold	< $\pm 1\%$
Operating Temperature	-20°F to 400°F (-28°C to 204°C)
Internal Leakage @ 3,000 psi (cis)	< $\pm 3\%$ rated flow plus < 0.50 cis tare
Proof Pressure	415 bar (6,000 psi) max (Supply), 275 bar (4,000 psi) (Return)
Burst Pressure	690 bar (10,000 psi) max (Supply), 345 bar (5,000 psi) (Return)

TECHNICAL HYDRAULIC DATA

Seal Material: FKM

System Filtration: High Pressure filter (without bypass but with dirt alarm) mounted in the main flow and if possible directly upstream of the valve.

Class of Cleanliness: The cleanliness of the hydraulic fluid greatly affects the performance (e.g., spool positioning, high resolution) and wear (e.g., metering edges, pressure gain, leakage) of the servo valves.

Recommended Cleanliness Class

- For functional safety ISO 4406 <17/14/11
- For longer service life ISO 4406 <16/13/10

Filter Rating recommended

- For normal operation $\beta_{10} \geq 75$ (10 μm absolute)
- For longer life $\beta_5 \geq 75$ (5 μm absolute)

Compatible Fluids: Petroleum base or selected phosphate ester fluid, 10 to 97 centistokes at 38°C (60 to 450 SSU at 100°F)

HYDRAULIC VALVE SYMBOL

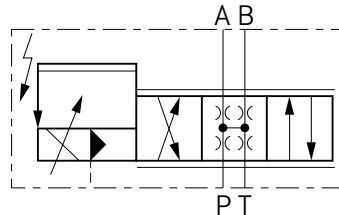

COIL RESISTANCE

The effects of coil resistance changes can be essentially eliminated through the use of a current feedback servoamplifier having a high output resistance, such as the Moog G1.23-825 Buffer Amplifier.

Parallel Coils			Series Coils			Single Coils		
R Ohms	L Henrys	i_R mA	R Ohms	L Henrys	i_R mA	R Ohms	L Henrys	i_R mA
40	0.18	40	160	0.56	20	80	0.22	40
100	0.59	20	400	2.2	10	200	0.72	20
500	2.6	10	2,000	9.7	5	1,000	3.2	10

Note:

1. Resistance values at 20°C (68°F) 10% tolerance
2. Inductance values are typical to 50 Hz, servovalve pressurized. Inductance is not normally measured on individual servo valves.

INSTALLATION DRAWING

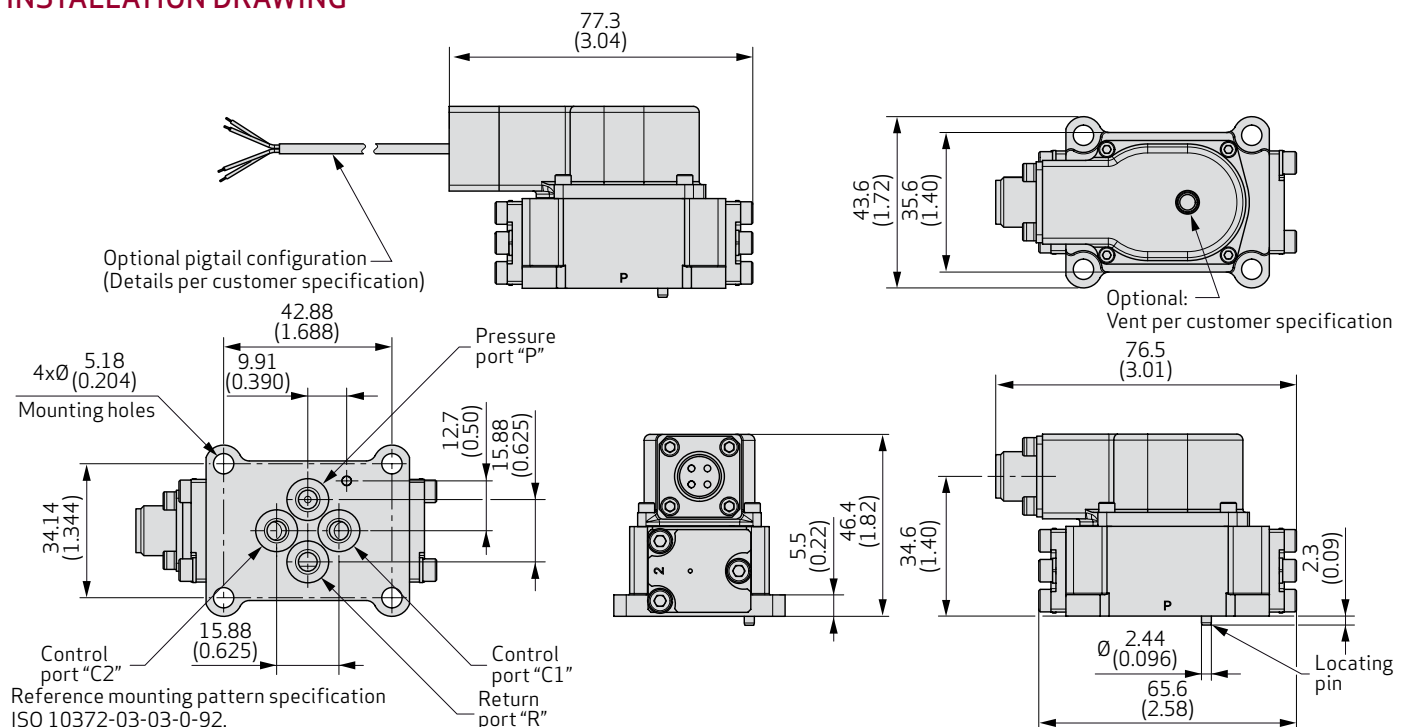

ORDERING INFORMATION

Model number (assigned at the factory)

-032	-					
------	---	--	--	--	--	--

Model designation
Assigned at the factory
Factory Identification (Revision Level)

1 Valve version
S Standard response

2 Rated flow in l/min (gpm)	For $\Delta p_N = 35$ bar (500 psi) per spool land	
15	15.1	(4.0)
23	22.6	(6.0)
31	30.2	(8.0)

3 Maximum operating pressure in bar (psi) and body material
H 275 (4,000) Stainless steel

4 Bushing/spool design
*O 4-way/axis cut/linear
C 4-way/ $\pm 3\%$ overlap/linear
D 4-way/ $\pm 10\%$ overlap/linear
N 4-way/ $\pm 3\%$ underlap/linear

Type designation

1	2	3	4	5	6	7	8	9	10	11

11 Vented Standard Motor Cap
*Standard Motor Cap
V Vented Motor Cap

10 Signals for 100 % spool stroke
G ± 10 mA single coil
J ± 20 mA single coil
L ± 40 mA single coil

9 Valve connector
A 4-Pin MS Threaded Connector over Port A
B 4-Pin MS Threaded Connector over Port B
1 4-Lead (18") Pigtail over Port B
2 4-Lead (18") Pigtail over Port A

8 Seal material
V Fluorocarbon (FKM) 85 Shore A

7 Pilot connections
4 Internal

6 Spool position without electrical signal
M Mid position

5 Pilot stage design
F Low flow, nozzle-flapper

*Preferred Models

MOOG GLOBAL SUPPORT

Moog Global Support is our promise to help you maximize uptime and get more from your machine investment. Moog has the expertise you can trust to perform the highest quality repairs to ensure like new performance for your servovalves. Only Moog technicians use authentic Moog OEM replacement parts to ensure "like-new" performance after every repair. Moog products are repaired to the original specifications and returned to you with a renewed warranty. Moog standard repair levels are available for this product and Moog offers options for express service in many of our locations.

Moog provides a wide variety of accessories that our customers may need for hydraulic valves. The Moog G123-825 Buffer Amplifier is a DIN Rail mount module that solves the common problem of the input signal being incompatible with the valve drive requirements. For more info visit www.moog.com or contact your local office.

Moog has offices around the world. For more information or the office nearest you, contact us online.

e-mail: info@moog.com

www.moog.com/industrial

Moog is a registered trademark of Moog Inc. and its subsidiaries. All trademarks as indicated herein are the property of Moog Inc. and its subsidiaries. ©2019 Moog Inc. All rights reserved. All changes are reserved.

32 Series Servo Valves
STAR PUBLISHING / Rev. B-, July 2019, Id. CDL57693-en

This technical data is based on current available information and is subject to change at any time by Moog. Specifications for specific systems or applications may vary.

MOOG