

## 63 Series Electrohydraulic Controllers

### SPECIFICATIONS

#### Rated Electrical Input:

- ± 50 ma dc, series coils
- ± 100 ma dc, single or parallel coils

#### Coil Resistance:

- 28 ohms each nominal at 70°F (21°C)\*\* (± 10% tolerance)

#### Nominal Voltage for Full Control:

- ± 2.8 volts, single or series coils
- ± 1.4 volts, parallel coils

#### Nominal Electrical Power for Full Command:

- ± 0.14 watts, series or parallel coils
- ± 0.28 watts, single coil

#### Nominal Swashplate Position Range:

± 18°

#### Hysteresis:

< 6%

#### Threshold:

< 2%

#### Linearity:

< 8%

#### Null:\*\* Externally Adjustable

#### Nominal Maximum Control Flow:

- ± 12.5 cis at 200 psi supply
- (± 12.5 lit/min at 14 bar)

#### Maximum Operating Pressure:

1000 psi (70 bar)

#### Normal Charge Pump Pressure:

200 ± 20 psi (14 ± 1.4 bar)

#### Rated Supply Proof Pressure:

2000 psi (140 bar)

#### Maximum Sump Back Pressure:

400 psi (28 bar)

#### Recommended Minimum Viscosity:

45 SSU

#### Recommended Maximum Viscosity:

6000 SSU

#### Seal Material:

VITON

#### Recommended Temperature Range:

-20°F to +200°F (-29°C to +93°C)

#### Fluid Cleanliness Level:

ISO DIS 4406 Code 16/13 max.

#### Long-Term Null Stability:\*\*

< ±7%

#### Dynamic Response:

See plots for performance with Sundstrand Type 22 or Eaton Type 39. Performance will vary with pump/motor size.

Note: Null offset of controller will cause dissymmetry between step responses for opposite pump directions.

\* Rated electrical input will vary for various pump sizes due to geometry of the connecting link. This may give full control for electrical inputs as much as 30% less than rated electrical input.

\*\* Mechanical null adjustment provided. Adjustment sensitivity approximately 20% change/half turn; full ±100% null adjustment available.

\*\*\* Resistance of each coil increases 7.8 ohms per 100°F (55°C) temperature rise.



The Moog Controller provides electrical control of the swashplate angle, and so eliminates the need for mechanical interconnection between the operator and the pump. Instead, a simple potentiometer can be located near the operator with a pair of electrical wires running to the Controller. Alternatively, the Controller permits electronic control of the pump-motor combination. Electronic control makes numerous automatic operations possible.

The Moog Controller is designed for direct mounting on Sundstrand and Eaton pumps and motors. Installation packages are available for various pump sizes.

### RESPONSE CURVES

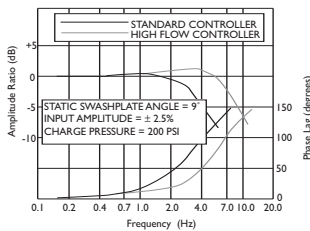

Typical Swashplate Frequency Response

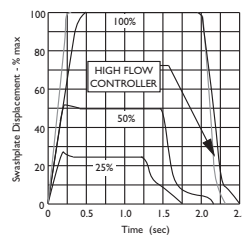

Typical Step Response - Unloaded Pump (200 psi charge pump pressure)

### FLOW CHARACTERISTICS

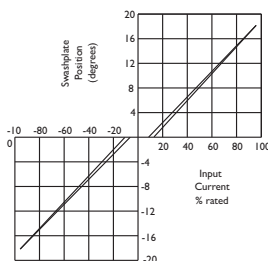

Typical Swashplate Control Characteristic

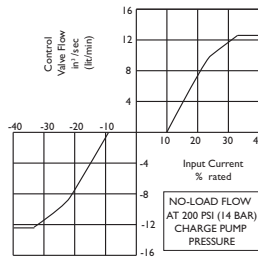

Typical Flow Characteristic - Standard Controller

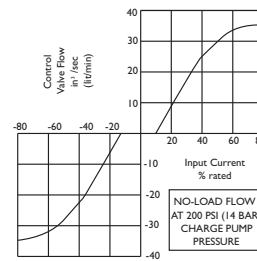

Typical Flow Characteristic - High Flow Controller

## HYDROSTATIC DRIVES

Variable displacement hydraulic pumps and motors are often used as a rugged, reliable and convenient way to transfer drive shaft power in a controlled fashion. These hydrostatic drives are used in construction vehicles and equipment, agricultural machinery, materials handling equipment, maritime vessels, machine tools, and even garden tractors and recreational vehicles.

In the usual application, a variable displacement pump is driven by the power source (diesel or gasoline engine, turbine, or electric motor). Flexible hydraulic lines connect the pump output to a hydraulic motor that drives the load.

Pump displacement is controlled by a manual lever throughout the range from zero to full flow in either direction. This sets the angle of the swashplate in the variable displacement piston pump and provides an infinitely variable transmission ratio to the load, from full forward to full reverse, without the use of a clutch or mechanical gear box. The lever can be manipulated by the operator to set the desired load speed. Often a series of levers, push rods, bell cranks, or cables are used to connect the operator to the pump control.

The hydraulic motor (or motors) can be conveniently located at the load, while the displacement pump is at the power source. The transmission ratio can be changed "on the fly" without damage to the pump or motor. Full load torque is available at stall, and optimum engine drive speed can be maintained at all times.

In light of these attributes, it is not surprising that hydrostatic drives have established themselves in popularity for an ever expanding array of applications.

## FEATURES AND BENEFITS

### High Reliability and Performance

- > Proven by use in numerous types of applications
- > Fast Response
- > Fail-safe feedback linkage returns the pump to neutral if there is a loss of electrical control, or if feedback linkage failure occurs
- > Strong feedback linkage
- > Less sensitive to null shift
- > Torque motor armature and flapper move in a frictionless fashion (no sliding fits) for excellent positioning accuracy of threshold and swashplate
- > Approximately 1/8 watt required for full control ( $\pm 1.40$  volts using parallel coils)
- > Controller occupies only a slightly larger space than a mechanical control mechanism

### Convenient Remote Control

- > Simple two-wire electrical connection eliminates all mechanical links, rods and cables
- > Dual torque motor coils permit remote control from two locations, or interconnections to give steering-type control

### Direct Interchangeability

- > In most installations, the Moog Controller can be powered by the charge pump
- > Feedback connects to swashplate linkage

### Compatible Response Characteristics

- > Control orifice plates used by several pump manufacturers can be used with Moog Controllers to tailor the response of a hydrostatic transmission

### OEM or Retrofit

- > Pump manufacturers will supply Moog Controllers on new units
- > Controllers can be retrofitted on most existing pumps
- > 63 Series Controllers are interchangeable with previous 62 Series

### Standard Features

- > Screens are provided in pressure and control ports to exclude chip ingestion
- > Weatherproof sealed
- > Two test ports are provided for checkout and troubleshooting (one for each control pressure)
- > Controller can be supplied pressure from sources other than the charge pump or its pressure line filtered source
- > Controller has a manual lever to permit operation with no electrical power

### Optional Pressure Override

- > Controller can be supplied with provisions for mounting a pressure override assembly

## OPERATION

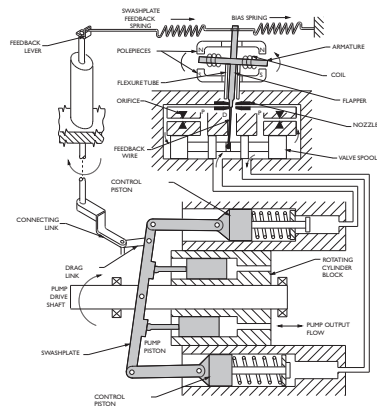

The Moog Controller\*, a replacement for the manual control lever and valve normally associated with hydrostatic drives, acts to position the swashplate in response to electrical commands.

Input to the controller is electrical current through the torque motor coils. This current produces a torque on the armature/flapper that is ultimately balanced out by deflection of the feedback spring due to swashplate movement.

The controller works as follows (refer to Figure 1): When the electrical input current changes, the torque balance at the armature/flapper is upset. This causes the flapper to move towards one nozzle. The

fluid flowing to this nozzle through the upstream orifice is then diverted and moves the spool. As the spool moves, the feedback wire that engages the center of the spool is deflected. This creates a feedback torque on the flapper that causes spool displacement to be proportional to the magnitude of torque unbalance at the input.

When the valve spool is displaced out of the null region, flow is ported to the control pistons. These pistons move to change the angle of the swashplate, and so change the displacement of the pump. As the swashplate moves, the feedback lever changes the pull on the swashplate feedback spring connected to the torque motor.

As the swashplate approaches the commanded displacement, the force from the swashplate feedback spring, together with the torque from the feedback wire, overbalance the electrical input torque. This causes the flapper to move toward the opposite nozzle. Nozzle flow is then diverted, moving the valve spool back to its centered position.

As the valve spool approaches its null position, the swashplate will stop moving. Final equilibrium is reached when the force from the feedback spring just balances the electrical input torque. This gives pump (or motor) displacement proportional in both magnitude and direction to the electrical command.

The valve spool in the Moog Controller is underlapped to drain and over-lapped to pressure. The underlap, in conjunction with the control piston return springs, gives a positive neutral deadzone.

\*Patent Nos. 3,023,782 and 3,228,423

## APPLICATIONS

### Set Point Speed Control

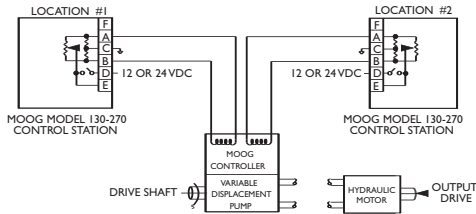

A remote command potentiometer provides the electrical signal for setting the speed of a hydrostatic drive. Moog Snap Trac electronics provide the necessary “black box” to complete the system. Various Snap Trac models are available for industrial use.

#### > Vehicle Speed Control

Speed control in a hydrostatically powered vehicle can be provided by simply attaching a potentiometer to the operator control and wiring it to a Moog pump controller. The minimal effort required to move the pot allows the operator control to be “human engineered” for optimum convenience. Forward/reverse control can be provided by a pot and two resistors (as used in the Model 130-270 Moog control station). This pump speed control can be used with a separate mechanical engine governor control, or it may be coordinated with a single engine speed/vehicle speed control.

#### > Combination And Other Controls

The control functions described here can be combined in various combinations to tailor a hydrostatic transmission operation to the specific requirements of an individual vehicle. In addition, a number of other control functions such as vibratory control, PTO speed control, cable play-out control, tension control, etc., can be provided. OEM's should consult the Moog factory for details.

### Closed Loop Servocontrol

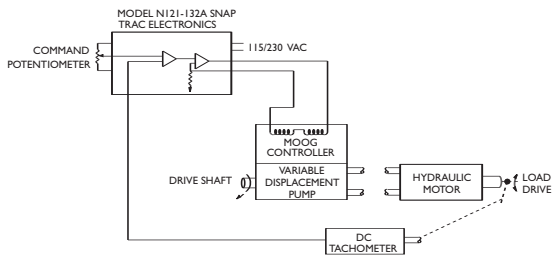

Highest accuracy will be achieved by measuring the output of the hydrostatic drive with an electrical transducer, and using the signal for feedback.

#### > Velocity Control

A DC tachometer can be attached to the hydrostatic drive output and provide the feedback to a Snap Trac Servocontroller for a velocity servoloop. Both proportional and integral control are provided by Moog Snap Trac Servocontrollers. In some installations, a pulse-type (non-contacting) pick-off is preferred. Moog can supply special electronics that adapt the pulse-train output to provide an analog DC signal for velocity feedback. Consult the factory for specifics.

#### > Acceleration/Deceleration Control

Oftentimes it is desirable to limit maximum acceleration (and deceleration) in a velocity servo. The Moog Model NI23-137 Snap Trac provides this limit control. The circuit includes a potentiometer that sets the maximum ramp (rate of change) of the error signal in a velocity servo.

## INSTALLATION

The Moog Controller is directly interchangeable with the manual valve on several Sundstrand models. It also mounts directly to several Eaton units with a simple spacer plate. In these direct mounted installations, the Moog Controller operates from the charge pump pressure. A suitable adaptor link is supplied in each installation kit to connect the swashplate feedback lever to the pump mechanism.

### Installation Kit

Kits containing the necessary hardware and instructions for installation of the Moog Controller are available for a number of Sundstrand and Eaton pumps and motors (see table at right). These kits contain the appropriate connecting link, screws and lockwashers, mounting bolts, interface gasket, O-Rings, and adaptor plate (if required).

### Special Applications

Special intrinsically safe controllers are available for mining and petrochemical applications. These controllers utilize a low voltage coil (4V) and diodes that prevent arc-over in the event of a wiring failure.

| Pump or Motor Type  | Swashplate Connecting Link P/N | Standard P/N | Installation Kit  |  |          |
|---|--------------------------------|--------------|---|--|----------|
|   |                                |              | with provisions for mounting Sundstrand pressure override P/N | includes adaptor manifold* for Eaton pump or motor P/N |          |
| Sundstrand  | 20, 21, 22                     | A37081-1     | A37083-1  | A37092-1   | N/A      |
|   | 23-09 & lower                  | A37081-2     | A37083-2  | A37092-2   | N/A      |
|   | 23-10 & higher                 | A37081-3     | A37083-3  | A37092-3   | N/A      |
|   | 24                             | A37081-4     | A37083-4  | A37092-4   | N/A      |
|   | 25                             | A37081-5     | A37083-5  | A37092-5   | N/A      |
|   | 26                             | A37081-6     | A37083-6  | A37092-6   | N/A      |
|   | 27                             | A37081-7     | A37083-7  | A37092-7   | N/A      |
| Eaton   | 33, 34, 36                     | A37081-30    | A37083-30   | N/A  | N/A      |
|   | 33, 39, 46, 54                 | A37081-9     | A37083-9  | N/A  | A37103-1 |
|   | 76, 107, 149                   | A37081-10    | A37083-10   | N/A  | A37103-2 |
| Installation Instructions*  |                                |              | Instructions P/N  |  |          |
| Sundstrand 20 and 30 Series<br>Sundstrand 20 Series with Pressure Override<br>Eaton |                                |              | A37102<br>A37057<br>A37469                                    |  |          |

\* Included in installation kit.

# MOOG

## 63 SERIES INSTALLATION

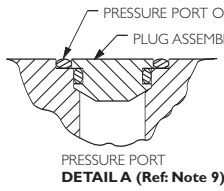
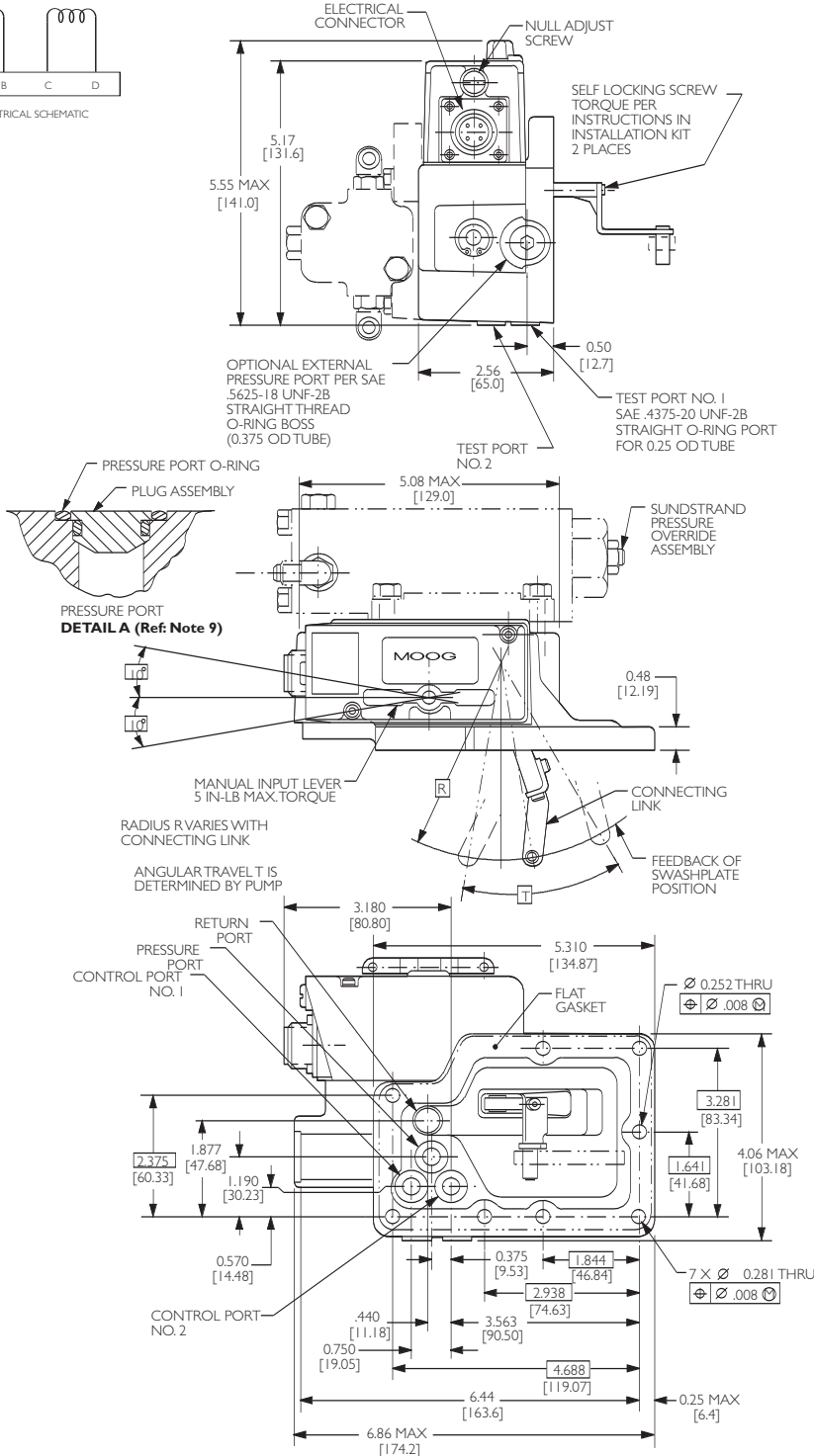
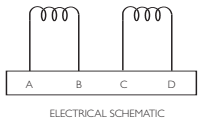

## SETUP AND CHECKOUT

Proper setup of the Moog Controls Controller on pumps and motors is described in the Installation Instructions which are included with the Installation Kits. Additional copies are available from the factory.

The use of a simple battery circuit (see below) can assist in setup and troubleshooting. This circuit provides about 20% of the rated control current which is sufficient to overcome deadband and produce a low level output from the hydrostatic drive.

Pressure gages can be connected to the controller test ports for accurate setup on a motor and to facilitate system troubleshooting.

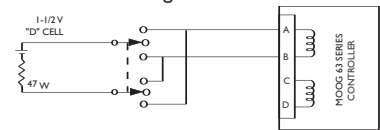

## INSTALLATION NOTES

- Exterior materials: aluminum alloy, zinc alloy and steel.
- \* Recommended seals: VITON (90 durometer) o-rings 0.070 (0.18) section x 0.489 (12.42) ID; P/N 42082-4.
- Mounting bolts: (3) 1/4 - 20NC x 3.00 long and (5) 1/4 - 20NC x 1.00 long. Torque per instructions in Installation Kit.
- Null adjustment: use 1/8" Allen wrench; ±2-1/2 turns max. Adjustment polarity: clockwise rotation increases flow out port 2.
- \* Flat gasket: P/N 5996-1.
- Mating electrical connector (environmental capability): P/N 49054FI4S2S.
- Electrical polarity: increase flow out port 2 with:
  - Series coils: B & C tied; A+, D-
  - Parallel coils: A & C, B & D tied; A+, D-
- \* Connecting link: must be ordered for specific pump model.
- When using external pressure port, remove pressure port o-ring and screen. Install optional pressure port o-ring plug assembly A37932-1. Reinstall pressure port o-ring. See Detail A.

\* Included in Installation Kit. Dimensions in parenthesis are in millimeters.

# MOOG

Industrial Controls Division

Moog Inc., East Aurora, NY 14052-0018

Telephone: 716/655-3000

Fax: 716/655-1803

Toll Free: 1-800-272-MOOG