

D661-G....A Series Servovalve With Bushing and Integrated 24 Volt Electronics ISO 4401 Size 05

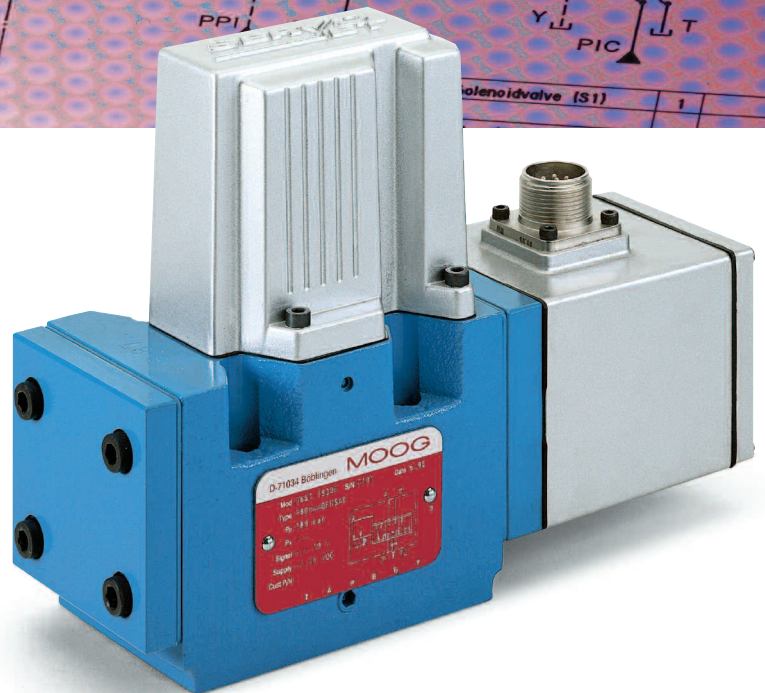
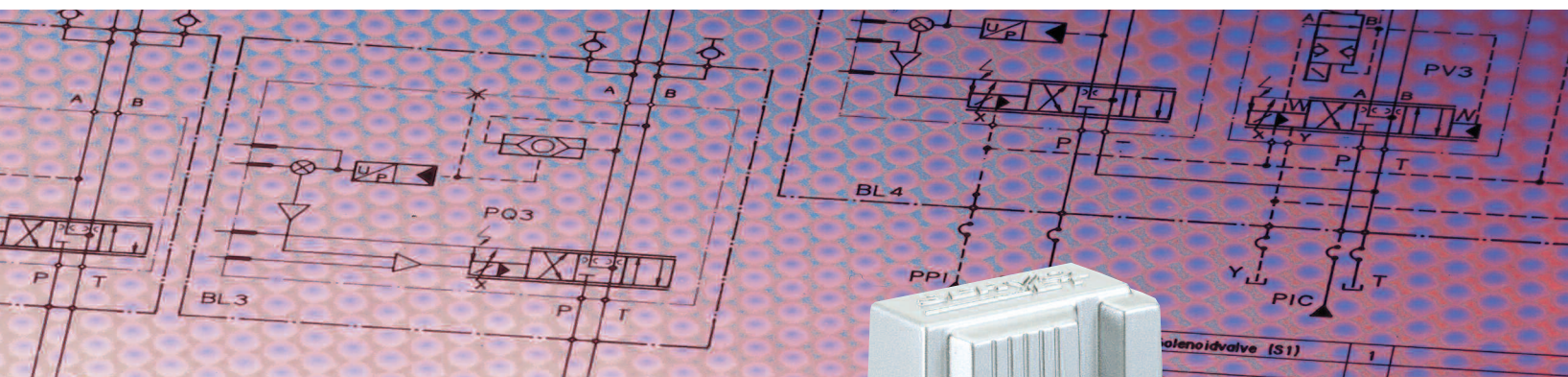

Section	Page
Overview	2-3
Technical Data	4-5
Performance Specs.	6-7
Electronics	8-9
Ordering Information	10

MOOG SERVO-PROPORTIONAL CONTROL VALVES

For over 25 years, Moog has manufactured proportional control valves with integrated electronics. During this time more than 150,000 valves have been delivered. These proportional control valves have been proven to provide reliable control of injection and blow molding equipment, die casting machines, presses, heavy industry equipment, paper and lumber processing and other applications.

D661-G...A SERIES SERVO-PROPORTIONAL CONTROL VALVES

The D661-G...A Series are servo-proportional flow control valves suitable for electrohydraulic position, velocity, pressure or force control systems, including those with high dynamic response requirements. The G...A represents the type designations codes for Moog's valve model numbers.

Moog has incorporated several design enhancements into the D661-G...A series servo-proportional valve. New 24 VDC electronics offer improved dynamic performance and a standard 4-20 mA spool position signal, which can be used for cable break detection. A servo quality bushing and spool provides a zero lap condition and a selection of nominal flow rates.

The D661-G...A Series design has a Moog's ServoJet® pilot stage that drives an electrically closed spool position loop. The jet pipe principle has been used reliably with different Moog valves for over 10 years, to reduce energy consumption and enhance the robustness of the valve. The redesigned ServoJet® pilot stage has reduced hysteresis and null shift, and improved pressure gain.

The bushing and spool assembly (BSA) and body for the D661-G...A (ISO 4401, size 05) was redesigned to improve pressure gain and increase flow to 20 gpm at 150 psi drop.

Other improvements in the D661-G...A Series, address many safety considerations in die-casting machines, injection-molding machines and presses. These include:

- The valve now places an optional enable signal at the operator's disposal. If no enable signal is available, the spool in the second stage moves to a predefined position (hydraulic zero or end position) depending on valve variant.
- The valve monitors supply voltage. If voltage on the updated valve (18 V up to 32 V) should drop below 18 V, the pilot signal will be disconnected and the spool will move to its predefined position (fail-safe). It will be monitored as soon as it reaches this position and will be confirmed by a logic output.
- The logic outputs are short circuit protected.



Our quality management system is certified in accordance with DIN EN ISO 9001.



The valve series described in this catalog have successfully passed EMC tests required by EC Directive. Please refer to the respective references in the electronics section.



Valves available with explosion protection to EN 50018, class EEx d II C-C₂ H₂ T5. Note: Installation dimensions and electric connection altered. Special data sheet on request.

This catalog is for users with technical knowledge. To ensure that all necessary characteristics for function and safety of the system are given, the user has to check the suitability of the products described herein. In case of doubt, please contact Moog.

Flexible Design Elements Optimize the Valve to Your Application

The D661-G....A Series Proportional Control Valves are a two-stage design. The spool motion of the main stage is produced by a single-stage pilot valve. Two-stage proportional valves are mainly used when low threshold and good dynamic response with small signals are required. By combining a fast first stage, a suitable spool drive area and integrated electronics, an optimum proportional valve can be offered.

Highest Flow Capability for High Velocity Applications

The D661-G....A Series valves offer the highest flow per body size.

Reduced Spool Drive Area for Improved Dynamic Response

The D661-G....A Series valves are available with a reduced diameter spool for higher valve dynamics.

Fail-Safe Versions for User Defined Spool Position at Loss of Power

Mechanical and electrically controlled fail-safe versions provide defined safe spool position by a spring and/or a poppet valve, and/or by external hydraulic supply cut off.

Improved ServoJet® Pilot Stage Dynamics for High Dynamic Valve Design

The high natural frequency of the ServoJet® pilot stage (500 Hz) allows for higher overall valve dynamic.

Flow Shaping Capabilities

Special configurations, such as parabolic and dual gain flows, can be produced for customers that need this capability. Contact factory for availability.

Improved Frequency Response for Superior Control System Performance

Improved frequency response of the ServoJet® pilot stage valve allows high spool position loop gain. The high loop gain provides excellent static and dynamic response, resulting in superior control system performance.

High ServoJet® Pilot Stage Pressure Recovery for Reliable Operation

The high-pressure recovery of the ServoJet® pilot stage (more than 80% ΔP at 100% command signal) provides higher spool driving forces and ensures enhanced spool position repeatability.

Improved Resistance to Contamination Reduces Downtime

The ServoJet® pilot stage valves have larger internal clearances making it more tolerant to contamination. The pilot stage filter has almost unlimited life due to an increased filter size (200 μm nominal fineness).

2-Stage Servo Valve

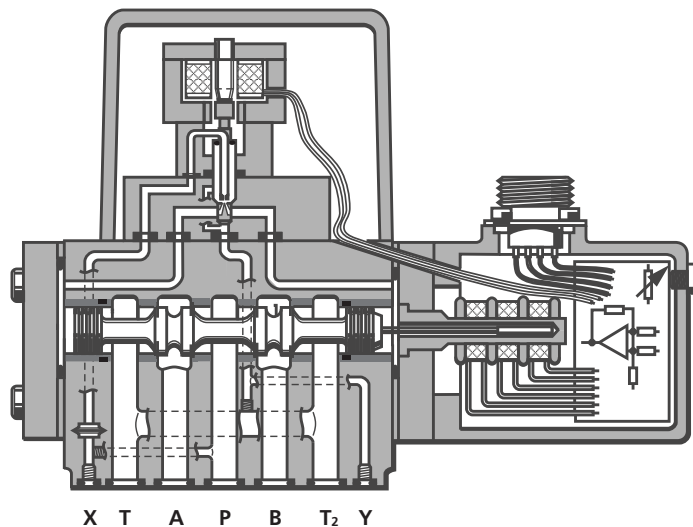

OPERATION

The flow control servovalves D661-G....A Series are throttle valves for 2-, 3- and 4-way applications. These valves are suitable for electrohydraulic position, velocity, pressure or force control systems including those with high dynamic response requirements.

The spool of the main stage is driven by a jet pipe pilot stage in an electrically closed loop.

The integrated electronics of the valve is a new development featuring SMD technology and requires 24 VDC power supply.

Operating Principle of the ServoJet® Pilot Stage

The ServoJet® pilot stage consists mainly of the torque motor, jet pipe and receiver. A current through the coil displaces the jet pipe from neutral. This displacement combined with the special shape of the nozzle directs a focused fluid jet more into one receiver opening than the other. The jet now produces a pressure difference in the control ports. This pressure difference results in a pilot flow which in turn causes a spool displacement. The pilot stage drain is through the annular area around the nozzle to tank.

An electric command signal (flow rate setpoint) is applied to the integrated control amplifier which drives the pilot stage. Thus, the deflected ServoJet® system produces a pressure difference across the drive areas of the spool and effects its movement. The position transducer, which is powered by an oscillator, measures the position of the spool (actual value, position voltage). This actual value is rectified by a demodulator and fed back to the control amplifier where it is compared with the command signal. The control amplifier drives the torque motor until command voltage and feedback voltage are equal. Thus, the position of the spool is proportional to the electric command signal.

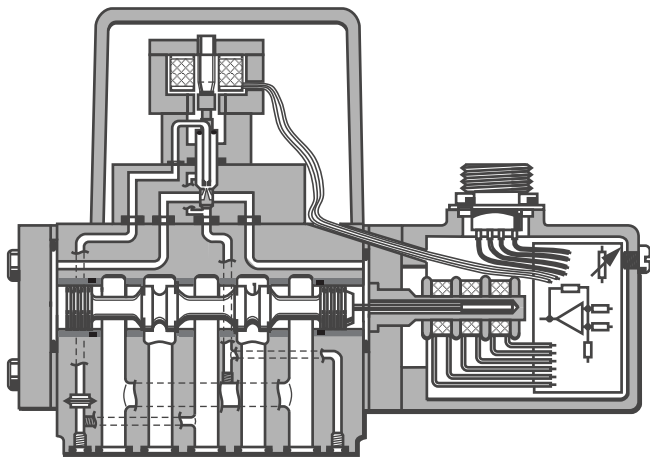

X T A P B T₂ Y

Hydraulic symbol:

Symbol shown with pilot pressure and electric supply on and zero command signal.

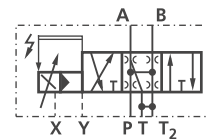

D661-G....A Series, 2-Stage Servo Valve
with ServoJet® pilot stage

PERFORMANCE SPECIFICATIONS FOR STANDARD MODELS

Operating pressure Range

- Ports P, A and B up to 5,000 psi [350 bar]
- Port T, T₂ for Y internal up to 3,000 psi [210 bar]
- Port T, T₂ for Y external up to 5,000 psi [350 bar]

Temperature Range

- Ambient -4°F to +140°F [-20°C to +60°C]
- Fluid -4°F to +176°F [-20°C to +80°C]

Seal Material

NBR, FPM and others on request
 mineral oil based hydraulic fluid (DIN 51524, part 1 to 3), other fluids on request

Operating Fluid

Viscosity

- Recommended 15 to 100 mm²/s
- Allowed 5 to 400 mm²/s

System Filtration

Pilot stage: high pressure filter (without bypass, but with dirt alarm) mounted in the main flow and if possible, directly upstream of the valve.
 Main stage: high pressure filter as for the pilot stage. When used in combination with a fast regulating VD-pump, a bypass filter is recommended.

Class of Cleanliness

The cleanliness of the hydraulic fluid greatly effects the performance (spool positioning, high resolution) and wear (metering edges, pressure gain, leakage) of the valve.

Recommended Cleanliness Class

- For normal operation ISO 4406 < 18 / 16 / 13
- For longer life ISO 4406 < 16 / 14 / 11

Filter Rating recommended

- For normal operation β₁₅ ≥ 75 (15 μm absolute)
- For longer life β₁₀ ≥ 75 (10 μm absolute)

Installation Options

any position, fixed or movable

Vibration

30 g, 3 axes

Degree of Protection

EN60529: class IP 65, with mating connector mounted

Shipping Plate

Delivered with an oil sealed shipping plate

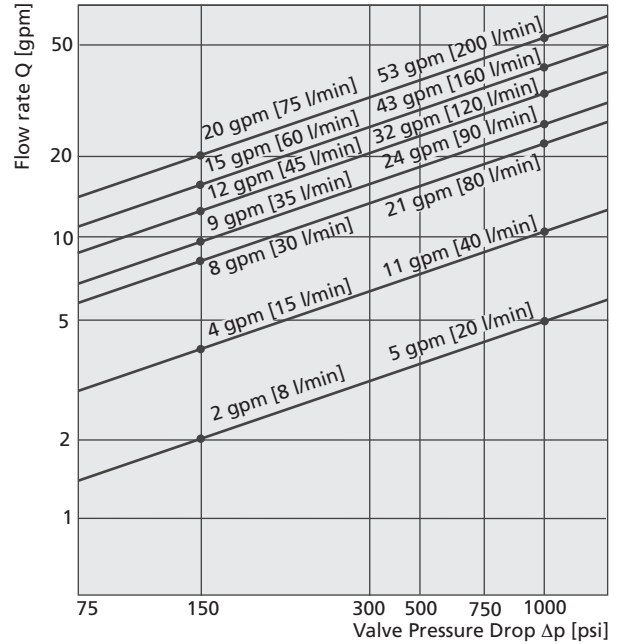

Valve Flow Diagram

Valve flow for maximum valve opening (100% command signal) as a function of the valve pressure drop

VALVE FLOW CALCULATIONS

A valve's flow is dependent upon its electric command signal and valve pressure drop. The flow for a given valve pressure drop can be calculated using the square root function for sharp edged orifices as follows:

$$Q = Q_N \sqrt{\frac{\Delta p}{\Delta p_N}}$$

Q [gpm] = calculated flow

Q_N [gpm] = rated flow

Δp [psi] = actual valve pressure drop

Δp_N [psi] = rated valve pressure drop

If large flow rates with high valve pressure drop are required, an appropriate higher pilot pressure has to be selected in order to overcome the flow forces. An approximate value can be calculated as follows:

$$P_x \geq 3.8 \cdot 10^{-2} \frac{Q}{A_k} \sqrt{\Delta p}$$

Q [gpm] = max. flow

Δp [psi] = valve pressure drop with Q

A_k [in²] = spool drive area

P_x [psi] = pilot pressure

The pilot pressure p_x has to be at least 350 psi [25 bar] above the return pressure of the pilot stage.

PERFORMANCE SPECIFICATIONS FOR STANDARD MODELS

		English [Metric]	D661-. . G . . A		
Mounting Pattern	ISO with additional 2nd T port		ISO 4401 - 05 - 05 - 0 - 94		
Valve Body Version			4-way 2-stage with bushing spool assembly standard		
Pilot Stage	ServoJet®		X and Y	X and Y	X and Y
Pilot Connection					
Mass		lb [kg]	12.57 [5.7]	12.57 [5.7]	12.57 [5.7]
Rated Flow	(±10%) at Δp _N = 500 psi [35 bar] per land	gpm [l/min]	5.3 [20]/23.8 [90]	10.6 [40]/21 [80]	31.7 [120]/42.3 [160]/52.8 [200]
Operating Pressure	max.				
Main Stage:	ports P with X external, A, B	psi [bar]	5,000 [350]	5,000 [350]	5,000 [350]
port T, T ₂ with Y internal	port T, T ₂ with Y internal	psi [bar]	3,000 [210]	3,000 [210]	3,000 [210]
Pilot Stage:	regular version	psi [bar]	5,000 [350]	5,000 [350]	5,000 [350]
	with dropping orifice (on request)	psi [bar]	4,000 [280]	4,000 [280]	4,000 [280]
Response Time*	for 0 to 100% stroke, typical	[ms]	5,000 [350]	5,000 [350]	5,000 [350]
Threshold*		[%]	8.0	14.0	18.0
Hysteresis*		[%]	< 0.10	< 0.08	< 0.05
Null Shift*	with ΔT = 55K	[%]	< 0.40	< 0.30	< 0.20
Null Leakage Flow*	total max. (~ critical lap)	gpm [l/min]	< 2.0	< 1.5	< 1.0
Pilot Leakage Flow*	typical	gpm [l/min]	0.79 [3.0] / 1.2 [4.5]	1.0 [3.8]	1.2 [4.5]
Pilot Flow*	max., for 100% step input	gpm [l/min]	0.45 [1.7]	0.45 [1.7]	0.45 [1.7]
Main Spool Stroke		in [mm]	± 0.05 [± 1.3]	± 0.08 [± 2.0]	± 0.12 [± 3.0]
Spool Drive Area		in ² [cm ²]	0.21 [1.4]	0.21 [1.4]	0.21 [1.4]

* measured at 3,000 psi [210 bar] pilot or operating pressure, respectively, fluid viscosity of 32 mm²/s and fluid temperature of 104°F [40°C]

Flow Gain in the Null Region
50 to 200% nominal

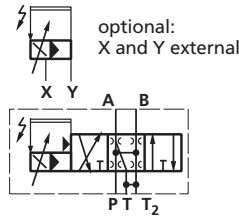
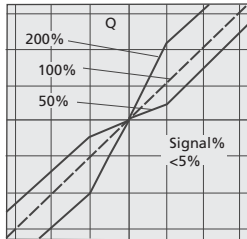

4-way version
fail safe type A: A ▶ T biased
(T₂ with Q_N > 160 l/min required)

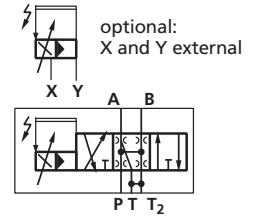

4-way version
fail safe type O
(T₂ with Q_N > 160 l/min required)

TYPICAL PERFORMANCE CURVES * measured at 3,000 psi [210 bar] pilot or operating pressure, respectively, fluid viscosity of 32 mm²/s and fluid temperature of 104°F [40°C]

Flow vs. Signal Curve
at Δp_N = 500 psi [35 bar] per land

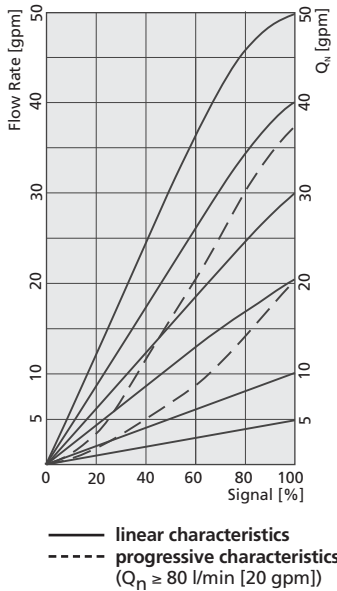

20/90 l/min Step Response

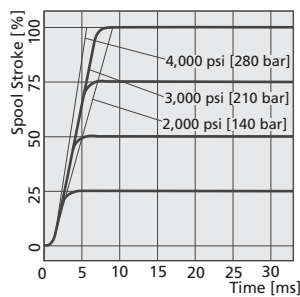

40/80 l/min

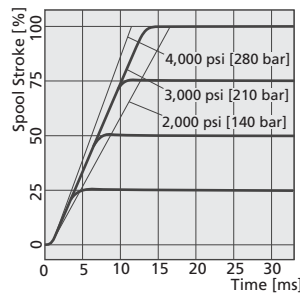

120/160/200 l/min

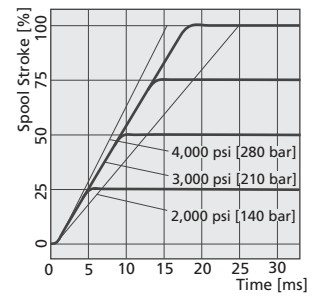

Frequency Response

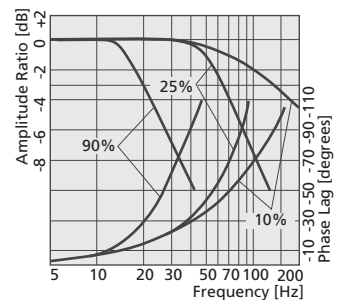
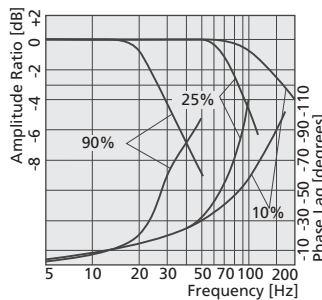
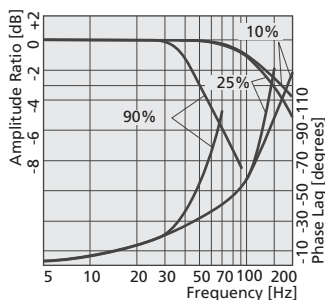

INSTALLATION DIAGRAM

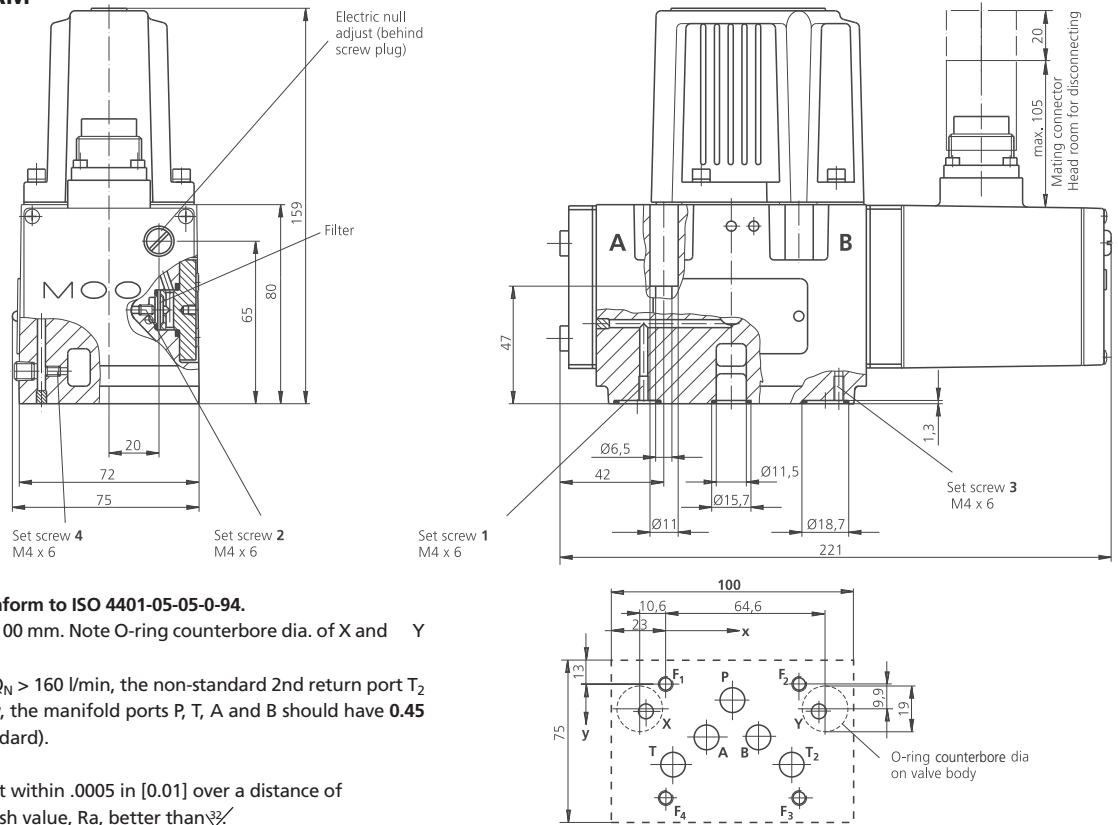

The mounting manifold must conform to ISO 4401-05-05-0-94.
 Attention: Manifold length min. 100 mm. Note O-ring counterbore dia. of X and Y ports.
 For valves in 4-way version with $Q_N > 160$ l/min, the non-standard 2nd return port T_2 must be used. For maximum flow, the manifold ports P, T, A and B should have 0.45 in [11.5] dia (deviation from standard).

Mounting surface needs to be flat within .0005 in [0.01] over a distance of 3.94 in [100]. Average surface finish value, Ra, better than $\sqrt{\text{ }}$

	P	A	B	T	T ₂	X	Y	F ₁	F ₂	F ₃	F ₄
	Ø0.45 [11.5]	Ø0.45 [11.5]	Ø0.45 [11.5]	Ø0.45 [11.5]	Ø0.45 [11.5]	Ø0.25 [6.3]	Ø0.25 [6.3]	M6	M6	M6	M6
x	1.1 [27.0]	0.66 [16.7]	1.5 [37.3]	0.15 [3.2]	2.0 [50.8]	-0.32 [-8.0]	2.4 [62.0]	0	2.1 [54.0]	2.1 [54.0]	0
y	0.25 [6.3]	0.84 [21.4]	0.84 [21.4]	1.3 [32.5]	1.3 [32.5]	0.43 [11.0]	0.43 [11.0]	0	0	1.8 [46.0]	1.8 [46.0]

SPARE PARTS AND ACCESSORIES

O-rings (included in delivery) for P, T, T ₂ , A, B for X, Y	5 pieces ID 0.49 [12.4] x Ø 0.07 [1.8] 1 piece ID 0.61 [15.6] x Ø 0.07 [1.8]	NBR 85 Shore 45122 004 45122 011	FPM 85 Shore 42082 004 42082 011
Mating connector, waterproof IP65 (not included in delivery) 6+PE	B97007 061	EN 175201-804	for cable diameter min. Ø 0.39 [10.0] max. Ø 0.47 [12.0]
Flushing plates	for P, A, B, T, T ₂ , X, Y B67728 001	for P, T, T ₂ , X, Y B67728 002	for P, T, T ₂ , and X, Y B67728 003
Mounting manifolds	see special data sheet		
Mounting bolts (not included in delivery) M6 x 60 DIN EN ISO 4762-10.9	A03665 060 060	required torque 115 in-lb [13 Nm]	required 4 pieces
Replaceable filter	A67999 200	200 µm nominal	
O-rings for filter change filter filter cover	1 piece ID 0.47 [12.0] x Ø 0.08 [2.0] 1 piece ID 0.67 [17.1] x Ø 0.10 [2.6]	HNBR 85 Shore - B97009 080	HNBR 85 Shore 66117 012 020 - FPM 85 Shore A25163 012 020 -

GENERAL REQUIREMENTS FOR VALVE ELECTRONICS

- Supply 24 VDC, min. 18 VDC, max. 32 VDC. Current consumption max. 300 mA
- All signal lines, also those of external transducers, shielded
- Shielding connected radially to \perp (0 V), power supply side and connected to the mating connector housing (EMC)
- **EMC:** Meets the requirements of EN 55011:1998 class B, EN 50082-2:1995, performance criteria class A
- Protective grounding lead $\geq .75 \text{ mm}^2$ [18 AWG]
Consider voltage losses between cabinet and valve.
- Note: When making electrical connections to the valve (shield, protective grounding), appropriate measures must be taken to ensure that locally different earth potentials do not result in excessive ground currents.

VALVE ELECTRONICS WITH 24 VOLT SUPPLY

**Command signal 0 to ±10 mA floating,
Valves with current command input**

The spool stroke of the valve is proportional to $I_D = -I_E$. 100% valve opening P → A and B → T is achieved at $I_D = +10$ mA. At 0 mA command the spool is in its center position. The input pins D and E are inverting. Either pin D or E is used according to the required operating direction. The other pin is connected to signal common at cabinet side.

**Command signal 0 to ±10 V,
Valves with voltage command input**

The spool stroke of the valve is proportional to $(U_D - U_E)$. 100% valve opening P → A and B → T is achieved at $(U_D - U_E) = +10$ V. At 0 V command the spool is in its center position. The input stage is a differential amplifier. If only one command signal is available the unused pin is connected to signal common at cabinet side, according to the required operating direction.

Actual value 4 to 20 mA

The actual spool position value can be measured at pin F (see diagram below). This signal can be used for monitoring and fault detection purposes. The spool stroke range corresponds to 4 to 20 mA. The centered position is at 12 mA. 20 mA corresponds to 100% valve opening P → A and B → T.

The position signal output 4 to 20 mA can be used to detect a cable break when $I_F = 0$ mA.

For failure detection purposes, it is recommended to connect pin F of the mating connector and route this signal to the control cabinet.

CIRCUIT DIAGRAM

Circuit diagram for measurement of actual I_F (position of main spool)

Note: Enable input

With enable signal off, the main spool will move to a safe position.

- a) Centered position (unbiased pilot valve function code A¹⁾)
- b) End position (biased pilot valve function code B¹⁾)

¹⁾ see type designation

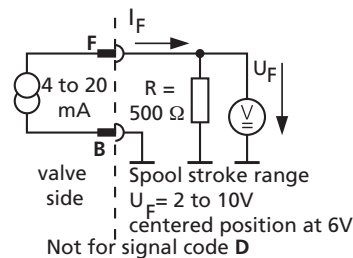

CONNECTOR WIRING

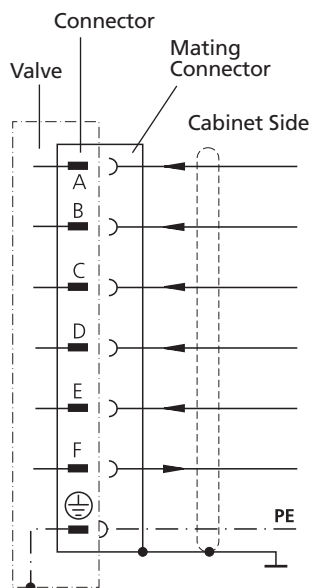

Wiring for valves with 6+PE pole connector (to EN 175201 Part 804²⁾) and mating connector (type R and S, metal shell) with leading protective earth connection

Function	Voltage Command	Current Command
Supply	24 VDC (min. 18 VDC, max. 32 VDC) $I_{max} = 300$ mA	
Supply/Signal Ground	⊥ (0 V)	
Enabled Not Enabled	$U_{C-B} > +8.5$ VDC $U_{C-B} < +6.5$ VDC	$I_e = 2.0$ mA at +24 VDC (see note above)
Input Rated Command (differential)	$U_{D-E} = 0$ to ± 10 V $R_e = 10$ kΩ	Input Command $I_D = -I_E: 0$ to ± 10 mA ($R_e = 200 \Omega$) Input Command (Inverted) $I_E = -I_D: 0$ to ± 10 mA
Output Actual Value spool position	$I_{F-B}: 4$ to 20 mA. At 12 mA spool is in centered position. $R_L = 100$ to 500Ω Signal code D: $U_{F-B} = 2$ to 10 V. At 6 V spool is in centered position. $R_a = 500 \Omega$	
Protective Earth		

²⁾ formerly DIN 43563

Model Number

D661

Type Designation

G S . 2

Specification Status	
-	Series specification
E	Preseries specification
K	Explosion proof version upon request
Z	Special specification

Model Designation	
	Assigned at the factory

Factory Identification	

Valve Version	
G	Standard spool

Rated Flow			
	Q _N [gpm] at Δp _N 1000psi [70 bar]	Q _N [l/min] at Δp _N 150 psi [10 bar]	Stroke in. [mm]
08	20	8	.051 [±1.3]
15	40	15	.078 [±2.0]
30	80	30	.078 [±2.0]
35	90	35	.051 [±1.3]
45	120	45	.118 [±3.0]
60	160	60	.118 [±3.0]
75	200	75	.118 [±3.0]

Maximum Operating Pressure	
B	1000 psi [70 bar]
H	4000 psi [280 bar] At p _x ≤ 280 bar (X and Y external) operating pressure in ports P, A, B and T up to 350 bar allowed.
K	5000 psi [350 bar]

Bushing/Spool Type	
O	4-way: ~ critical lap, linear characteristic
S	4-way: ~ critical lap, curvilinear characteristic, > Q _N = 80 l/min
X	Special bushing on request

Pilot Stage Version	
A	ServoJet®

Function Code	
O	No enable input. Pin C not used
A	Without enable signal applied the spool moves to adjustable centered position
B	Without enable signal applied the spool moves into defined end position A ↗ T or B ↗ T

Valve Dynamics	
H	Standard performance
-	Reduced performance on request

Supply Voltage	
2	24 V _{DC} (18 to 32 V _{DC})

Signals for 100% Spool Stroke		
	Command	Output
D	±10 V	2 to 10 V
M	±10 V	4 to 20 mA
X	±10 mA	4 to 20 mA

Valve Connector		For Supply Voltage	
S	6+PE	EN 175201 Part 804	— 2

Seal Material	
N	NBR (Buna) Standard
V	Fluorocarbon optional

Pilot Connections		
	Supply	Return
4	internal	internal
5	external	internal
6	external	external
7	internal	external

Spool Position without Electrical Supply		
O	Undefined (no fail-safe function)	
	Mechanical fail-safe version	Achieved at
A	P ↗ B, A ↗ T connected	p _x > 365 psi [25 bar]
B	P ↗ A, B ↗ T connected	p _x > 365 psi [25 bar]

Preferred configurations are highlighted. Options may increase price. Technical changes are reserved. All combinations may not be available. Please contact Moog.

NOTES

D661-G...A



Argentina
Australia
Austria
Brazil
China
England
Finland
France
Germany

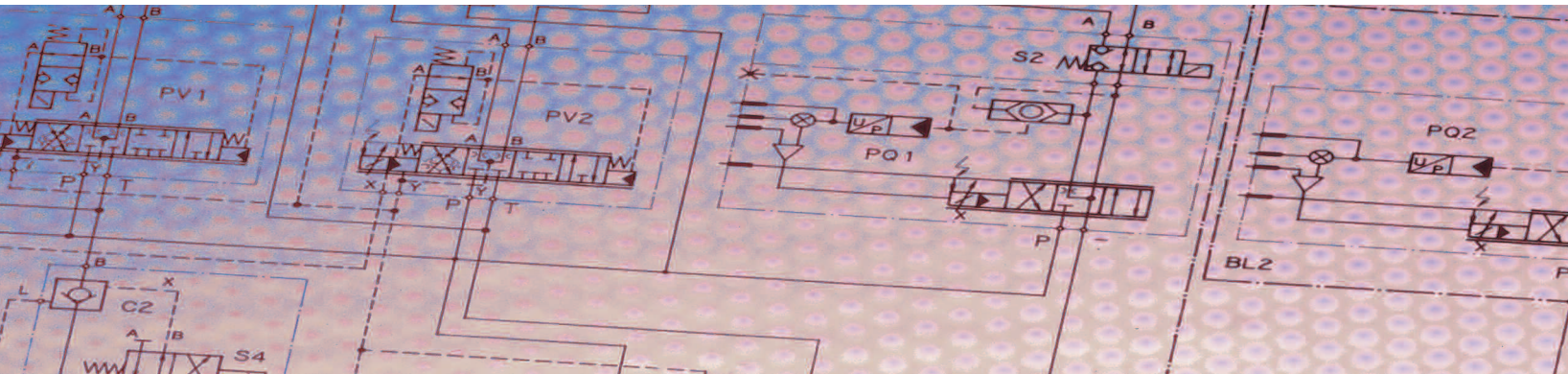

India
Ireland
Italy
Japan
Korea
Luxembourg
Norway
Russia
Singapore
Spain
Sweden
USA

MOOG

Moog Industrial Controls Division
East Aurora, NY 14052 -0018
Telephone: 716/652-2000
Fax: 716/687-7910
Toll Free: 1-800-272-MOOG
www.moog.com