Moog GmbH
Hydraulic Controls Engineering (HCE)

User Manual



QAIO 2/2 AV

**Analog Extension Module
with Pulse Input**

Version: 1.1
September 2006

Table of Contents

1	Introduction	3
2	Short Description.....	4
2.1	General	4
2.2	Features	4
2.3	Outputs/Inputs.....	4
2.4	Module Status LEDs	4
2.5	Configuration.....	4
2.6	Actuation	4
2.7	E-Bus	4
2.8	Technical Data	5
2.9	Accessories.....	6
3	View of the Module and Terminal Assignment.....	7
3.1	View of the Module.....	7
3.2	Terminal assignment.....	8
4	Analog Outputs	9
4.1	Basic Wiring Diagram.....	9
4.2	Specifications	9
4.3	Reference Voltage Output.....	11
5	Analog Inputs	12
5.1	Basic Wiring Diagram.....	12
5.2	Specifications	12
5.3	Connecting Analog Sensors.....	14
6	Pulse Input	19
6.1	Operation of digital inputs of QAIO 2/2:	19
6.2	Hardware:.....	19
6.3	Electrical specification:.....	20
6.4	Pulse frequency	20
6.5	Software	20
6.6	Usage constraints	21

1 Introduction

This user manual is an extension to the

User Manual

M3000® Control System
Control System
MSC (Moog Servo Controller)
Control Module

Pay attention to the chapters “General Information“ and “Safety Instructions“ of this user manual.

2 Short Description

2.1 General

The QAIO 2/2 analog module is used for local extension of the inputs and outputs (I/O) of the Moog Servo Controller (MSC) control module. The analog levels are identical to the levels of the MSC. The module is mounted on a DIN top-hat rail and directly connected to the MSC via the internal extension bus (E-Bus).

2.2 Features

Analog I/O extension module with pulse input.

- 2 analog inputs
- 2 analog outputs
- 1 reference voltage output +10 V
- Pulse input
- Connection via E-Bus

2.3 Outputs/Inputs

- 2 analog inputs, each configurable in the MACS development environment as ± 10 V, ± 10 mA or 4-20 mA. The inputs are converted in multiplex operation.
- 2 analog outputs, each ± 10 V, additionally individually configurable in the MACS software as ± 10 mA, ± 50 mA or 4-20 mA with wire fault monitoring
- 1 reference voltage output
The reference voltage source provides a short circuit protected voltage of +10 V.
- 1 pulse input 24 V useable as counter input or frequency measurement input

2.4 Module Status LEDs

On the front, 4 LEDs provide information about the status of important module functions.

2.5 Configuration

The configuration of the analog I/O is carried out per software via the central control configuration in the Moog Axis Control Software (MACS) development environment. Either the two analog inputs or the pulse input can be used.

2.6 Actuation

The I/O of the analog extension module is actuated directly from the MSC (not D136X001-001 and D136E001-001) via the extension bus (E-bus). All input- and output-data are transferred within one cycle of the E-Bus. Therefore the module is perfect for fast control tasks.

2.7 E-Bus

One MSC can be extended with a maximum of 7 QAIO 2/2 modules. It is not possible to combine it with QAIO 16/4 on one E-Bus segment.

2.8 Technical Data

Module data	QAIO 2/2-AV I/O extension module
Order number	D137-001-011
Connection to M3000 modules	Via E-Bus (10 MHz) Please note: <ul style="list-style-type: none"> It is not possible to connect the module to an MSC D136X001-001 or D136E001-001 Combination with QAIO 16/4 V or QAIO 16/4 A on one E-Bus segment is not possible All QAIO 2/2 A/V modules must be connected next to the E-Bus master MSC. Further E-Bus modules may be connected right to the QAIO 2/2 A/V modules.
Connection technique	Plug-in terminal strips for screwing or clamping
Mounting	Mounting rail NS 35/7.5 pursuant to EN 50022 (DIN top-hat rail)
4 module status LEDs	Module functions and diagnosis
Dimensions, WxHxD	124 x 170 x 85.5 (attachment dimension: W = 113/118.5) mm 4.88 x 6.69 x 3.37 (attachment dimension: W = 4.45/4.67) inch
Temperature range	+5°C (+41°F) to +55°C (+131°F) (operation) and -25°C (-13°F) to +70°C (+158°F) (storage) Mean temperature in operation for 24 hrs.: max. +50°C (+122°F)
Relative air humidity	10 % to 95 % (non-condensing)
Operation height	Max. 2000 m (6500 ft); storage/transport max. 3000 m (9800 ft)
Standards	
Operating equipment demands and examinations	IEC 61131-2
Interference emission / immunity	EN 61000-6-4 / EN 61000-6-2, industrial part
Shock / vibration	IEC 60068 part 2-27 / IEC 60068 part 2-6
Protection class / protection system	III / IP20
Insulation strength	IEC 61131-2; test voltage 500 V DC
Energy Supply	
Voltage supply of module electronics	+24 V DC (18-32 V DC) SELV pursuant to DIN EN 60950-1
Current consumption of module electronics	max. 0.25 A
Potential separation	Separate potentials for: module electronics, 24 V energy supply, pulse input
Internal voltages	Internally generated via DC/DC converters
Protection against reverse polarity	Yes
Analog Inputs	
2 analog inputs	16 Bit; individually configurable in the MACS development environment as ±10 V, ±10 mA or 4–20 mA; overvoltage protection up to ±36 V
Analog Outputs	
2 analog outputs	16 Bit; each ±10 V, additionally individually configurable in the MACS development environment as ±10 mA, ±50 mA or 4–20 mA Overvoltage protection up to ±36 V; short-circuit protected

Reference for sensors	
Reference voltage output	+10 V; max. load: 5 mA Overvoltage protection up to $\pm 36V$; short circuit protected
Pulse input	
Pulse input	24 V digital input can be used as input pursuant to IEC 61131-2 type 1 Positive switching (input OE) or ground switching Either the two analog inputs or the pulse input can be used.

2.9 Accessories

Accessories		
Plug-in terminal strips (two 18-pole and one 9-pole are required per module)		
Designation	Description	Order number
Screw terminal 18-pole	Up to max. conductor cross-section of 2.5 mm ² (14 AWG)	VK055-018
Screw terminal 9-pole	Up to max. conductor cross-section of 2.5 mm ² (14 AWG)	VK055-009
Spring latch clamp 18-pole	Up to max. conductor cross-section of 2.5 mm ² (14 AWG)	B95907-018
Spring latch clamp 9-pole	Up to max. conductor cross-section of 2.5 mm ² (14 AWG)	B95907-018

3 View of the Module and Terminal Assignment

3.1 View of the Module

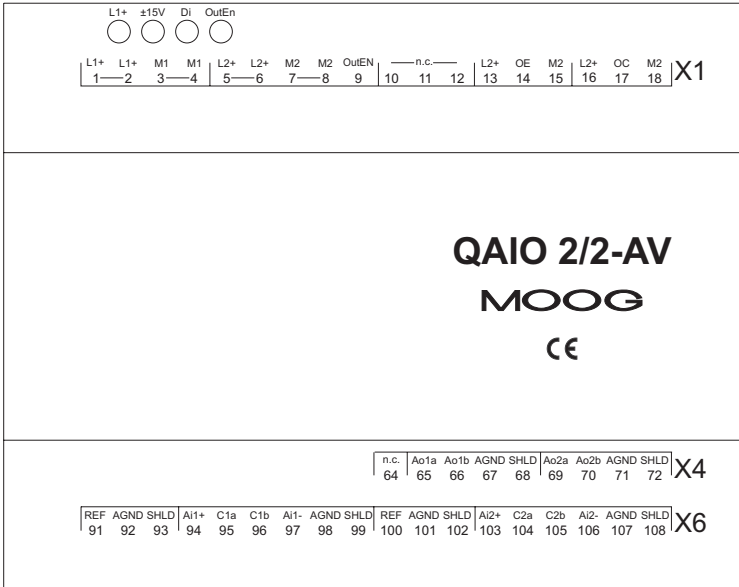

3.2 Terminal assignment

QAIO 2/2-AV Terminal Assignment				
Conn.	Term. Nr.	Function	Description	
X1	1	L1+	+24V Supply Module	
	2	L1+	+24V Supply Module	
	3	M1	GND Supply Module	
	4	M1	GND Supply Module	
	5	L2+	+24V Supply Digital Output + Sensors	
	6	L2+	+24V Supply Digital Output + Sensors	
	7	M2	GND Supply Digital Output + Sensors	
	8	M2	GND Supply Digital Output + Sensors	
	9	OutEN	Digital Output 'Outputs Enabled'	
	10			
	11			
	12			
	13	L2+	+24V Supply Sensor 1	Pulse input OE
	14	OE	Open Emitter Output Sensor 1	
	15	M2	GND Supply Sensor 1	
	16	L2+	+24V Supply Sensor 2	Pulse input OC
	17	OC	Open Collector Output Sensor 2	
	18	M2	GND Supply Sensor 2	
X4	64	n.c.		
	65	Ao1a	Analog Output 1 Voltage Output (referenced to AGND)	Analog Output 1
	66	Ao1b	Analog Output 1 Current Output (referenced to AGND)	
	67	AGND	Analog Ground	
	68	SHLD	optional Shield Connection	
	69	Ao2a	Analog Output 2 Voltage Output (referenced to AGND)	Analog Output 2
	70	Ao2b	Analog Output 2 Current Output (referenced to AGND)	
	71	AGND	Analog Ground	
72	SHLD	optional Shield Connection		
X6	91	REF	+10V Reference Voltage Output	
	92	AGND	Analog Ground	
	93	SHLD	optional Shield Connection	
	94	Ai1+	Analog Input 1 non inverting	Analog Input 1
	95	C1a	Input Current Sample Resistor (connect to C1b)	
	96	C1b	Input Current Sample Resistor (connect to C1a)	
	97	Ai1-	Analog Input 1 inverting	
	98	AGND	Analog Ground	
	99	SHLD	optional Shield Connection	
	100	REF	+10V Reference Voltage Output	
	101	AGND	Analog Ground	
	102	SHLD	optional Shield Connection	
	103	Ai2+	Analog Input 2 non inverting	Analog Input 2
	104	C2a	Input Current Sample Resistor (connect to C2b)	
	105	C2b	Input Current Sample Resistor (connect to C2a)	
	106	Ai2-	Analog Input 2 inverting	
107	AGND	Analog Ground		
108	SHLD	optional Shield Connection		

4 Analog Outputs

4.1 Basic Wiring Diagram

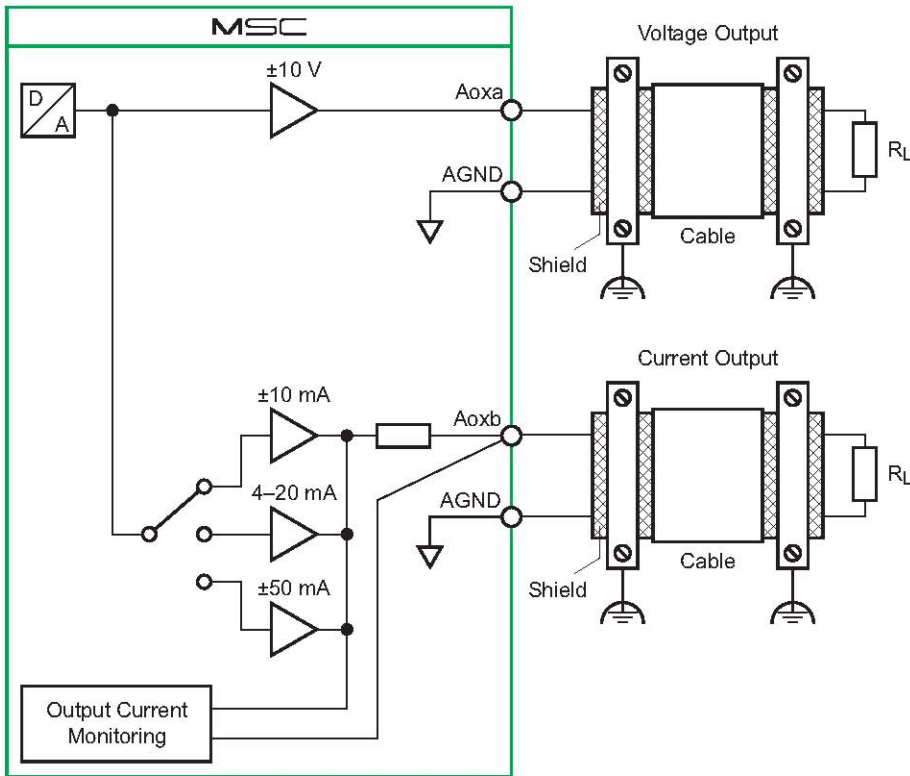

Basic Wiring Diagram of an Analog Output of the MSC

Figure 58: Basic Wiring Diagram of an Analog Output Aox of the MSC (when Used as a Voltage and Current Output)

4.2 Specifications

Number of analog outputs

2

Analog output type

Voltage output ± 10 V nominal

Additionally one current output each:

configurable as: ± 10 mA, ± 50 mA or 4–20 mA (each nominal)

i The analog outputs are configured in the PLC configuration of the MACS development environment.

Output impedance within nominal signal range

< 0.2 W (voltage output)

Approx. 1 MW (current outputs)

Greatest error over the entire temperature range

±1 % of full scale value

Output ranges

nominal	minimal	maximal	LSB Value
±10 V	-10,92 V	+10,92 V	0,333 mV
±10 mA	-10,92 mA	+10,92 mA	0,333 µA
±50 mA	-54,61 mA	+54,61 mA	1,667 µA
4–20 mA	+3,262 mA	+20,74 mA	0,267 µA

Output Ranges of QAIO 2/2 Analog Outputs

Digital resolution

16 bit

Data format in the application program

32 bit floating point

Load impedance range

Voltage output ±10 V: $\geq 1.000 \Omega$

Current output ±10 mA: $\leq 1.000 \Omega$

Current output ±50 mA: $\leq 200 \Omega$

Current output 4–20 mA: $\leq 500 \Omega$

i The load impedance range of the current output 4–20 mA does not comply with IEC 61131-2. (IEC 61131-2 requires a load impedance range of $\leq 600 \Omega$.)

Update time

The update time corresponds to the task interval of the application program that actuates the output.

i The task interval (and thereby the update time of the outputs) is set in the task configuration of the MACS development environment.

Rise time $T_{10/90}$

Output		Step		R_L	typ. $T_{10/90}$
		from	to		
Voltage Output	±10 V	+10 V	-10 V	$\geq 1.000 \Omega$	60 µs
		-10 V	+10 V		
Current Output	±10 mA	+10 mA	-10 mA	1.000 Ω	60 µs
		-10 mA	+10 mA		
	±50 mA	+50 mA	-50 mA	200 Ω	125 µs
		-50 mA	+50 mA		
	4-20 mA	20 mA	4 mA	500 Ω	70 µs
		4 mA	20 mA		

Rise time $T_{10/90}$ of QAIO 2/2 Analog Outputs

Protection

Continuous short-circuit protection; overvoltage protection up to ±36 V

Short-circuit current I_{Kmax}

Voltage output ±10 V: $I_{Kmax} = \pm 15 \text{ mA}$

Current output ±10 mA: $I_{Kmax} = \pm 10.92 \text{ mA}$

Current output ±50 mA: $I_{Kmax} = \pm 54.61 \text{ mA}$

Current output 4–20 mA: $I_{Kmax} = \pm 20.74 \text{ mA}$

Recommended cable types

Use only shielded cables.

The shield must be made of copper braiding with at least 80% coverage.

The wire must be made of copper with a cross section of at least 0.25 mm^2 (23 AWG).

In environments with a high amount of disturbance, use cables with twisted pair wires.

Calibration

The QAIO 2/2 is calibrated at the factory and does not require any additional calibration.

Permissible load types

Resistive load according to "Load impedance range"

i The stability of the current outputs is ensured up to an inductive load of 100 mH.

i The stability of the voltage outputs is ensured up to a capacitive load of 10 μF .

Output current of the voltage output

Max. 10 mA

Wire fault monitoring of the analog current outputs

The analog current outputs are monitored for wire faults. The status of the wire fault monitoring can be evaluated in the application program.

4.3 Reference Voltage Output

Reference voltage

+10 V DC

Load current

Max. 5 mA

Precision

$\pm 0.3 \%$ of full scale value

Temperature coefficient

$< 280 \mu\text{V/K}$

Output impedance

$< 0.2 \Omega$

Protection

Continuous short-circuit protection; overvoltage protection up to $\pm 36 \text{ V}$

Short-circuit current

$I_{K\text{max}} = 15 \text{ mA}$ (residual current of the terminals 91 (REF) and 100 (REF) of the connector X6)

5 Analog Inputs

5.1 Basic Wiring Diagram

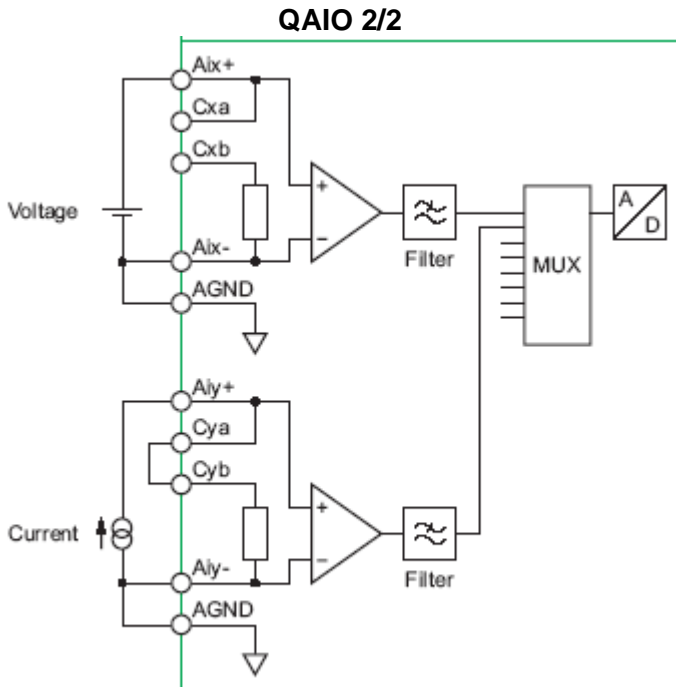

Basic Wiring Diagram of the Analog Inputs Ai1...Ai2 of the QAIO 2/2

The upper analog input Aix is configured as a voltage input, the lower analog input Aiy as a current input.

i An analog input Aix can only be used as a current input if the terminal Cxa is connected to the terminal Cxb.

Example: If Ai2 will be used as an analog current input, C2a must be connected to C2b.

i Insertion bridges for connecting the QAIO 2/2 terminals Cxa and Cxb are available from Moog as accessories.

5.2 Specifications

Number of analog inputs

2

Type of analog inputs

Differential, configurable as: ± 10 V, ± 10 mA or 4–20 mA (each nominal)

The analog inputs are configured in the PLC configuration of the MACS development environment.

Common-mode properties

Common-mode rejection: > 85 dB

Common-mode voltage range: ± 17 V

Input impedance within nominal signal range

> 100 k Ω on voltage inputs

200 Ω on current inputs

Greatest error over the entire temperature range

±0.5 % of full scale value

Permissible measurement range

nominal	minimal	maximal	LSB value
±10 V	-10,92 V	+10,92 V	0,333 mV
±10 mA	-10,92 mA	+10,92 mA	0,333 µA
4–20 mA	+3,262 mA	+20,74 mA	0,267 µA

Permissible Measurement Range of QAIO 2/2 analog inputs

Max. permissible continuous overload (higher load results in damage)

±36 V on voltage inputs

±36 mA on current inputs (or ±6.4 V without current limiting)

Digital resolution

16 bit

Data format in the application program

32 bit floating point

Output values when below or above measurement range

Maximum or minimum values: see “Permissible Measurement Range”

Conversion method

Successive approximation

Duration of conversion per input

Typ. 12.5 µs

Sampling time

The sampling time corresponds to the task interval of the application program that reads the input. All 2 analog inputs are sampled continuously in succession, i.e., every analog input is updated every 25 µs (max. 2 inputs à 12.5 µs of conversion time). The most recent value is used in the application program.

 The task interval (and thereby the sampling time of the inputs) is set in the task configuration of the MACS development environment.

Protective device

Diodes

Recommended cable types

Use only shielded cables.

The shield must be made of copper braiding with at least 80% coverage.

The wire must be made of copper with a cross section of at least 0.25 mm² (23 AWG).

In environments with a high amount of disturbance, use cables with twisted pair wires.

Calibration

The QAIO 2/2 is calibrated at the factory and does not require any additional calibration.

Crosstalk between inputs

<0.02%

5.3 Connecting Analog Sensors

Recommended cable types

Use only shielded cables. The shield must be made of copper braiding with at least 80% coverage. The wire must be made of copper with a cross section of at least 0.25 mm² (23 AWG). In environments with a high amount of disturbance, use cables with twisted pair wires.

5.3.1 Shielding Signal Cables

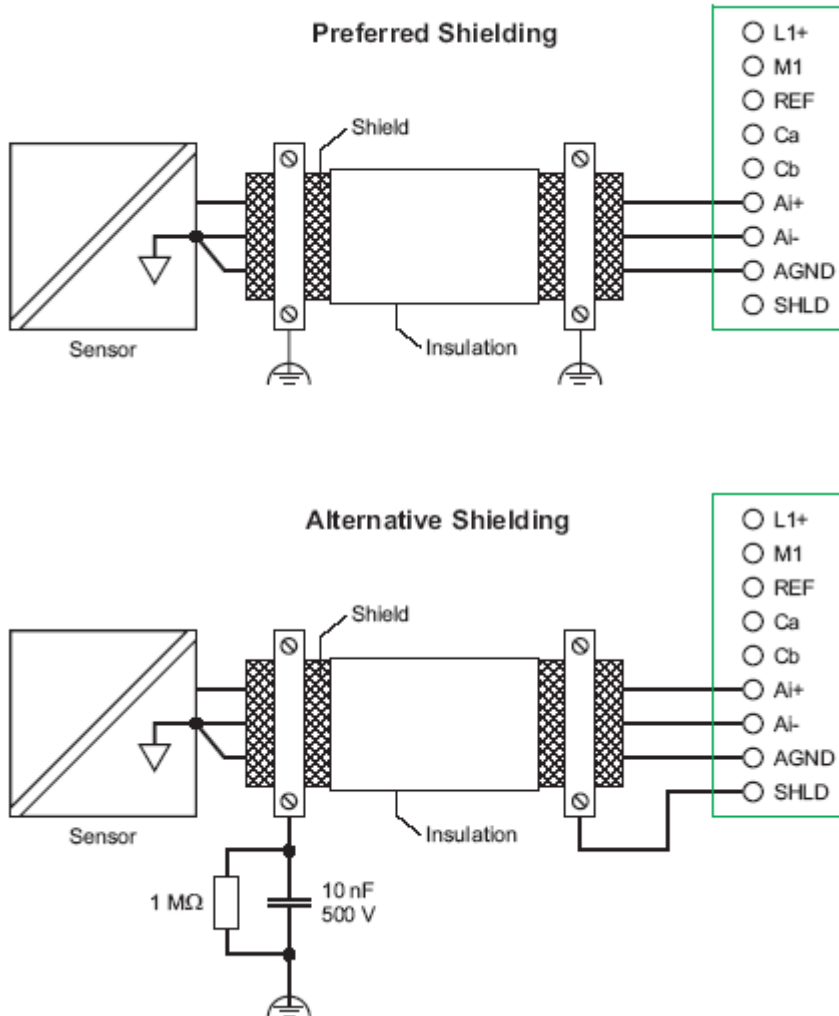

Shielding the Signal Cable when Connecting an Analog Sensor to the QAIO 2/2

5.3.2 Isolated Sensors

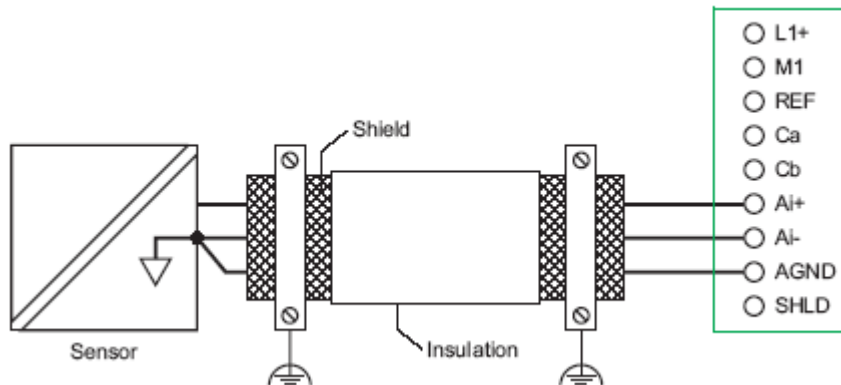

Connecting an Isolated Analog Sensor to the QAIO 2/2 (Voltage Signal)

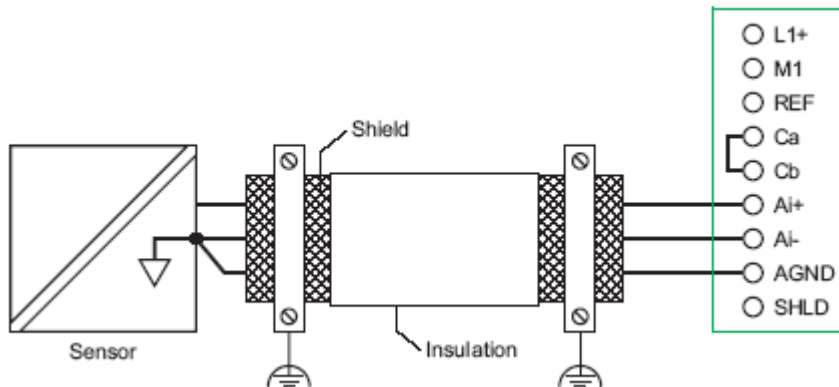

Connecting an Isolated Analog Sensor to the QAIO 2/2 (Current Signal)

5.3.3 Non-Isolated Sensors

Sensors with their own auxiliary energy connection

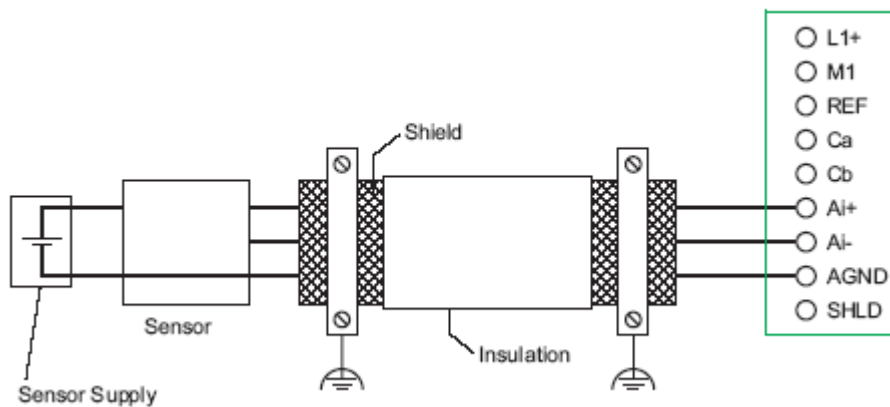

Connecting a Non-Isolated Analog Sensor (Voltage Signal) with its Own Auxiliary Energy Connection to the QAIO 2/2

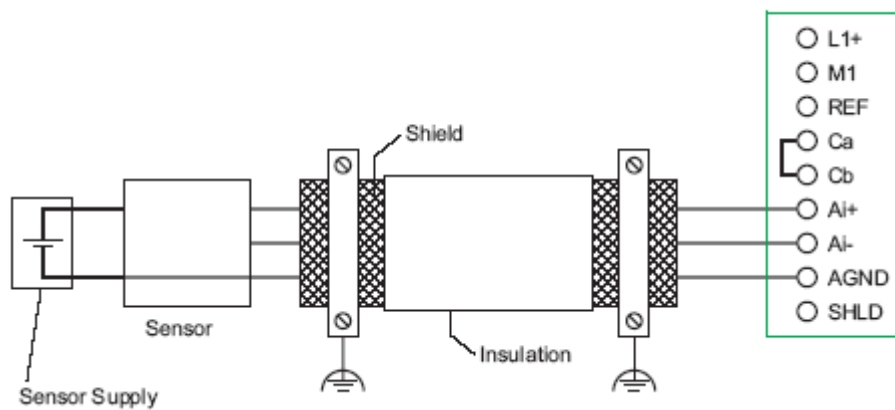

Connecting a Non-Isolated Analog Sensor (Current Signal) with its Own Auxiliary Energy Connection to the QAIO 2/2

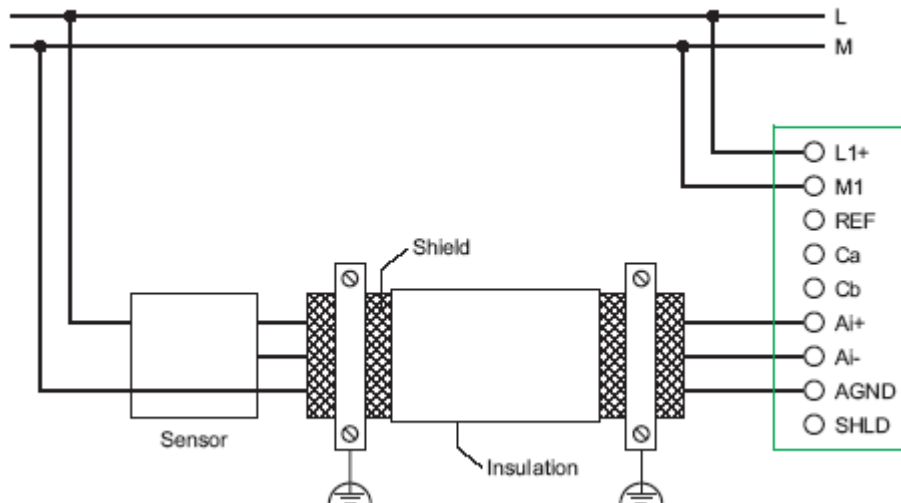

Connecting a Non-Isolated Analog Sensor (Voltage Signal) with the Same Auxiliary Energy Connection as the QAIO 2/2

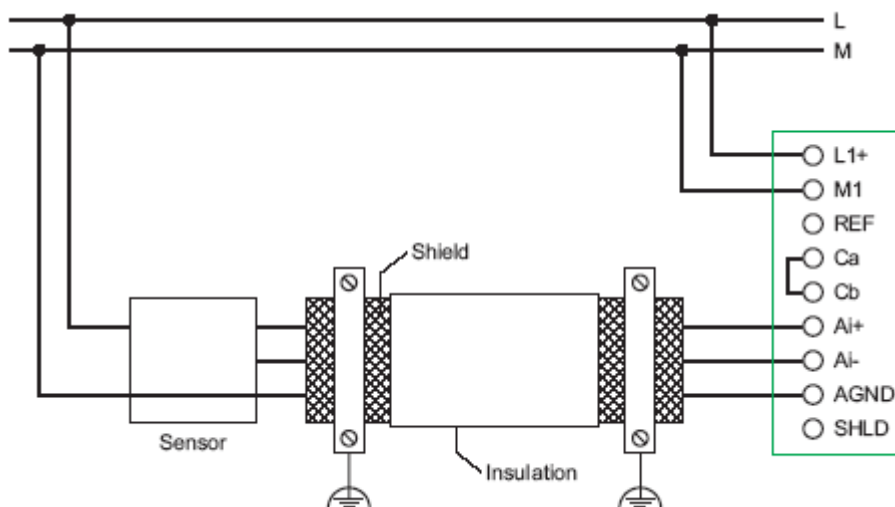

Connecting a Non-Isolated Analog Sensor (Current Signal) with the Same Auxiliary Energy Connection as the QAIO 2/2

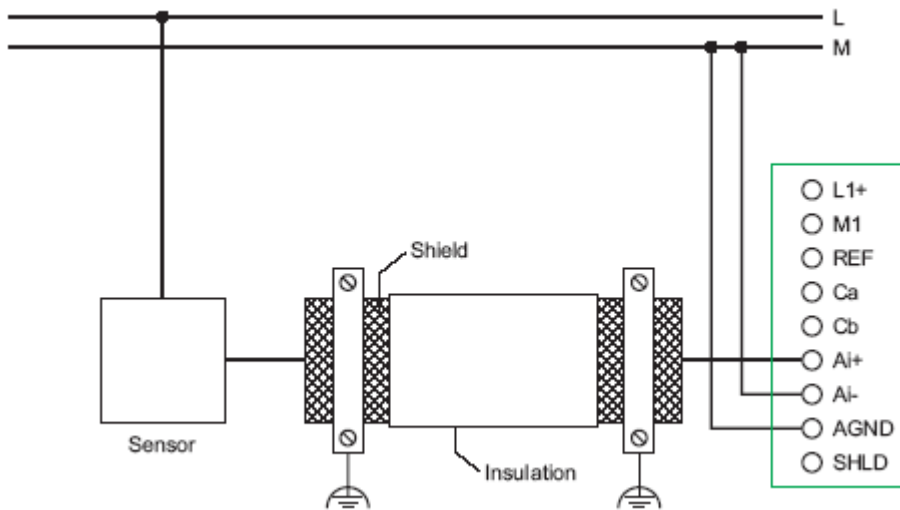

Connecting a Non-Isolated Two Wire Analog Sensor (Voltage Signal) with the Same Auxiliary Energy Connection as the QAIO 2/2

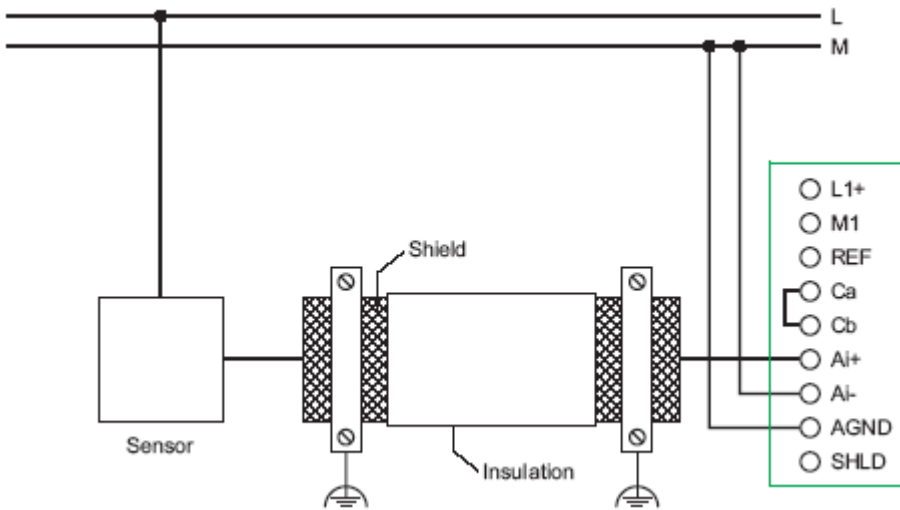

Connecting a Non-Isolated Two Wire Analog Sensor (Current Signal) with the Same Auxiliary Energy Connection as the QAIO 2/2

5.3.4 Using the Internal Reference Voltage of the QAIO 2/2

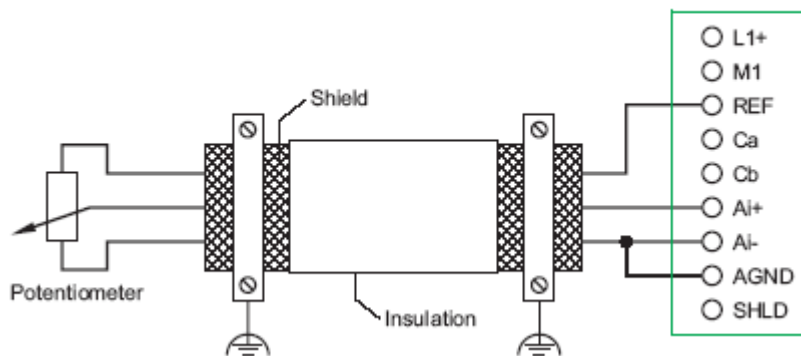

Connecting a Potentiometer to the QAIO 2/2 Using the Internal Reference of the QAIO 2/2

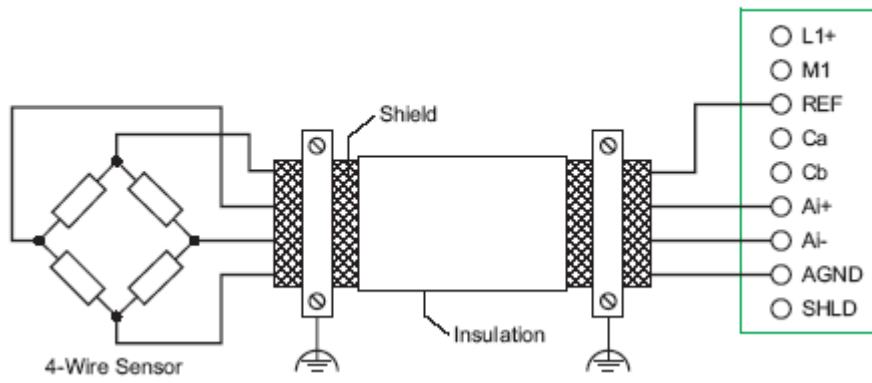

Connecting an Analog 4-Wire Sensor to the QAIO 2/2
Using the Internal Reference Voltage of the QAIO 2/2

6 Pulse Input

6.1 Operation of digital inputs of QAIO 2/2:

To use any digital input of the QAIO 2/2, the analog inputs of the module must be disabled. Both digital channels of the QAIO 2/2 are used as pulse counting inputs. In this mode only one of the two inputs can be active. The configuration can be done completely with the MACS software of the E-Bus master module.

6.2 Hardware

Digital Input OE:

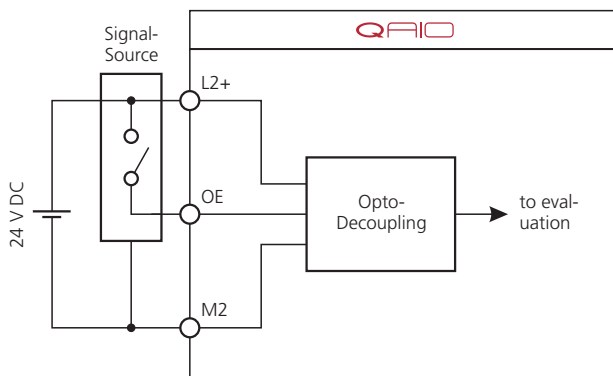

Digital Input OC:

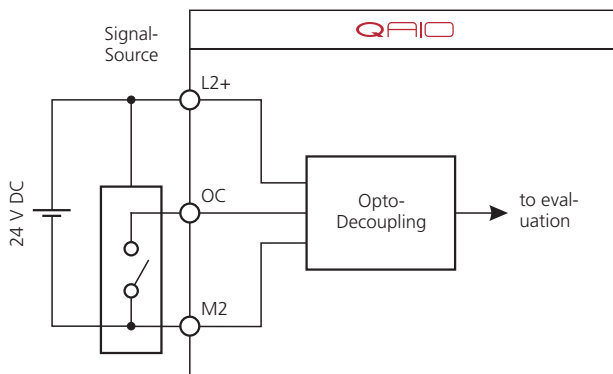

6.3 Electrical specification:

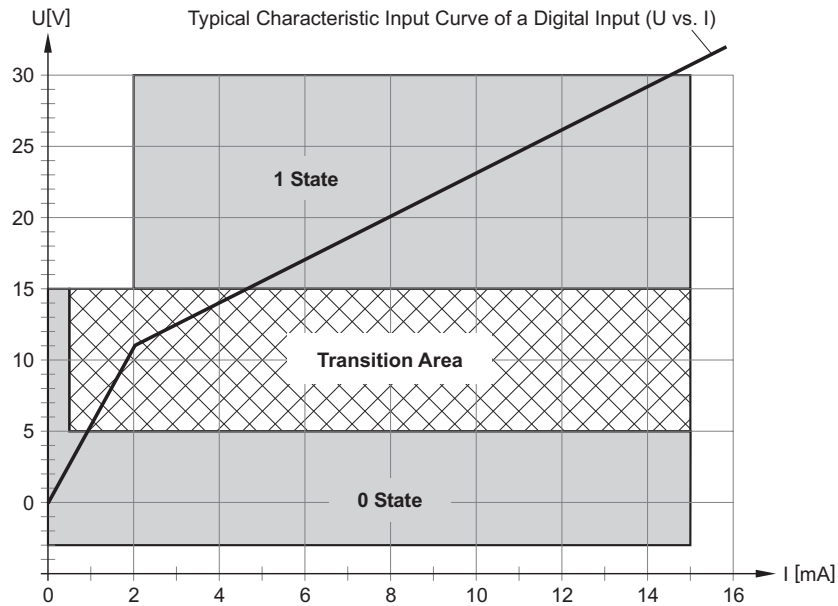

U/I working ranges of digital inputs:

Digital input OE:	$U_e = OE - M2$	Rated Voltage $U_e = 24V$
Digital input OC:	$U_e = L2 - OC$ (ground reference point: M2)	upper limit $U_e \max = 32V$
		lower limit $U_e \min = 18V$
Limits for the 1 state		upper limit $U_{H\max} = 30V$ $I_{H\max} = 15mA$
		lower limit $U_{H\min} = 15V$ $I_{H\min} = 2mA$
Limits for the 0 state		upper limit $U_{L\max} = 15/5V$ $I_{L\max} = 15mA$
		lower limit $U_{L\min} = -3V$ $I_{L\min} = ND$

6.4 Pulse frequency

Pulses with a minimum pulse width of 200ns (5MHz) are detected by the electronics. The counter register value is incremented by 1 at any occurrence of a falling edge at the digital input in use.

6.5 Software

Configuration:

The configuration of the QAIO 2/2 is done by the E-Bus master module. For that purpose a QAIO 2/2 module must be placed as an E-Bus slave. To use any digital input, the operation mode "Analog input" has to be changed to "Pulse counter" or "Frequency measurement". In both cases the QAIO 2/2 works as a pulse counter. The calculation of the frequency is done by the E-Bus master module. The time base for this calculation is the cycle time of the task with the highest priority.

6.6 Usage constraints

When using QAIO 2/2 modules in a E-Bus chain, it is not possible to use QAIO 16/4 modules at the same time in the same E-Bus group. The MACS software avoids this and displays an error message.

When using QAIO 2/2 modules in combination with QDIO 16/16 modules in the same E-Bus group, it is necessary to use the QAIO 2/2 modules close to the E-Bus master and align the QDIO 16/16 modules on the right side of the E-Bus group.