

# 2-WAY SLIP-IN ACTIVE CARTRIDGE

ISO 7368 SIZES 16 TO 100  
CHE series

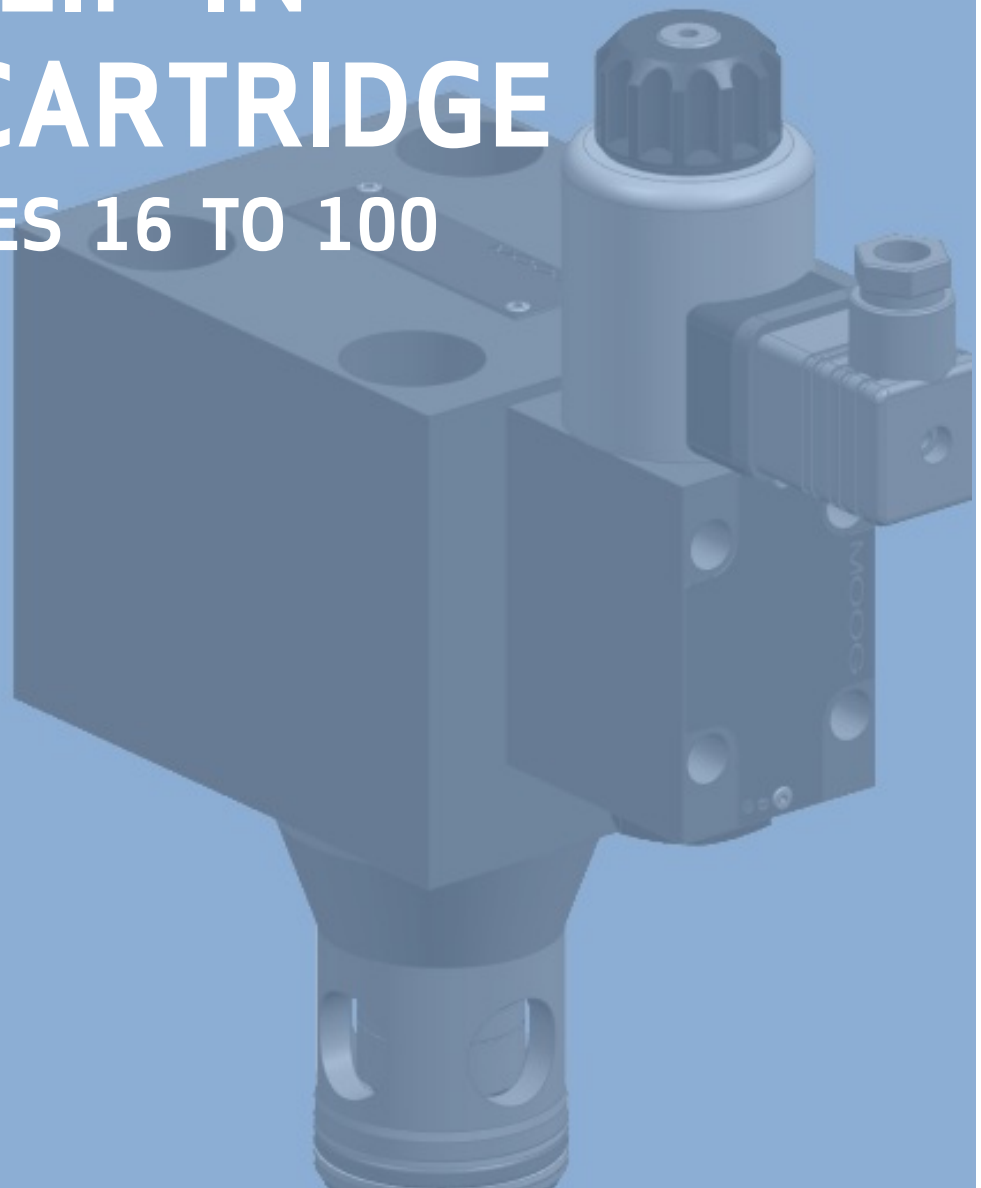

Rev. D, May 2022

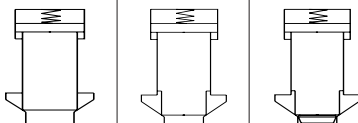
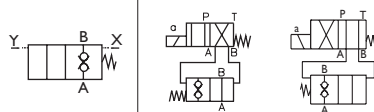

Designation	Symbol	Page
General Description		4
Features and Types of Cones and Sleeves		5
Specifications and Characteristic Parameters		6
Performance Data		7-9
Standard Models X-Cone, S-Cone, T-Cone		10-12
Standard Models Covers		13
Typical Orifice Characteristics		14
Dimensions Hydraulically Operated, Solenoid Operated		15-16
Dimensions		17
Ordering Information		18-19
Configuration		20
Spare Parts		21

This catalogue is for users with technical knowledge. To ensure that all necessary characteristics for function and safety of the system are given, the user has to check the suitability of the products described herein. In case of doubt please contact Moog.

# General Description

Moog Active Cartridge valve was designed to eliminate many of the limitations of Standard Cartridge Valves. The Active Cartridge contains an additional control area that provides more robust control of switching pressure for high speed and response machines where low system pressure can delay closing times. In essence, Active Cartridges have a double acting pilot piston for 4-way directional control of the cone or poppet, whereas a Standard Cartridge uses a single acting piston for 3-way control.

As a result, the Active Cartridge can offer improvements in:

- Closing time
- Opening time
- Closing under load

An Active Cartridge may be used for the following functions:

- Hydraulically pilot operated check or direction control
- Solenoid pilot operated check or direction control

**Standard Cartridge**

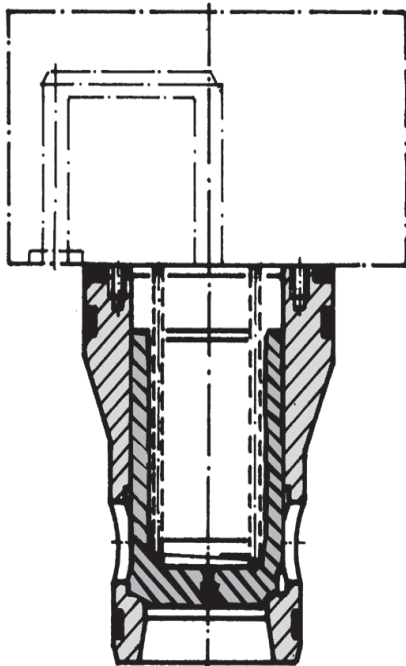

**Active Cartridge**

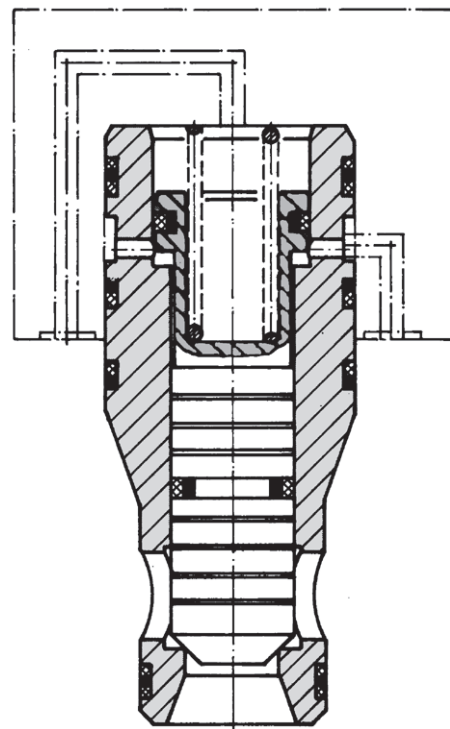

- All pilot and poppet seals create tight fit at all ports to prevent leakage in either direction
- Can operate without a spring when a defined spool position is not required and hydraulic system pressure is down
- Cartridge can be closed by a considerably lower control pressure at X due to the larger control surface area  $A_X$  (compared to the surface area  $A_A$ )
- Opening function and velocity of the cartridge are independent of the pressure in the working ports A and B
- Ability to be equipped with X-, S-, T-, and special cones
- Sizes NG16 to NG100 per ISO 7368

## Types of Cones and Sleeves

### Sleeve A, Cone X:

An active-cartridge with sleeve-A and cone-X (differential area  $A_B = 0$ ) can be used for all directional and check functions where a larger flow area and lower pressure losses are desired. With non-active control, the flow of this cartridge can only be from A to B.

Sleeve A, Cone X

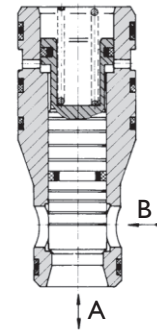

### Sleeve B, Cone S:

Used in all directional, check, and flow control functions.

Due to the cone differential area  $A_B > 0$ , the flow direction can be chosen also with non-active control.

Sleeve B, Cone S

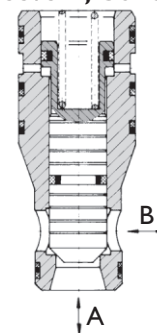

### Sleeve B, Cone T:

Cone T, with a dampening nose, can be used to avoid additional pressure peaks in tank circuits or to obtain a better adjustment of flow control valves.

Sleeve B, Cone T

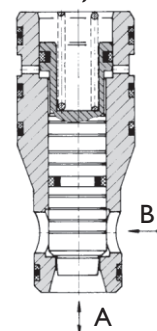

# Specifications

General Data	Value	Unit	Specifications
Designation and Symbol	—	—	2-way Slip-In Cartridge Valve
Mode of Construction	—	—	Pilot Operated Seat Valve
Mounting Type	—	—	Manifold Mounting
Mounting Pattern	—	—	ISO 7368:1989-08
Mounting Dimensions	—	—	See Mounting Dimensions Page 17
Mounting Position	—	—	Any
Flow Direction	—	—	A $\leftrightarrow$ B
Ambient Temperature Range	min.	°C	-25°
	max.	°C	+60°
<b>Working Pressure</b>			
Inlet	max.	bar	350
Outlet	max.	bar	350
Temperature Range	min.	°C	-10 (FKM) -20 (NBR)
	max.	°C	+80°
Viscosity Range	min.	mm <sup>2</sup> ·s <sup>-1</sup> [cSt]	2,8
	max.	mm <sup>2</sup> ·s <sup>-1</sup> [cSt]	380
Operational Viscosity	V <sub>n</sub>	mm <sup>2</sup> ·s <sup>-1</sup> [cSt]	35
Nominal Bore Size	—	mm	<b>NG16</b> <b>NG25</b> <b>NG32</b> <b>NG40</b> <b>NG50</b> <b>NG63</b> <b>NG80</b> <b>NG100</b>
Weight	m	kg	0,4 0,8 1,5 3,2 5,5 11,2 24,1 39,2
Pilot Volume (S & T Cones)	V <sub>x</sub>	cm <sup>3</sup>	2,00 8,00 17,00 29,00 77,00 191,00 285,00 494,00
Pilot Volume (X Cone)	V <sub>x</sub>	cm <sup>3</sup>	2,03 7,70 17,10 32,60 77,00 190,50 285,00 492,50

# Characteristic Parameters

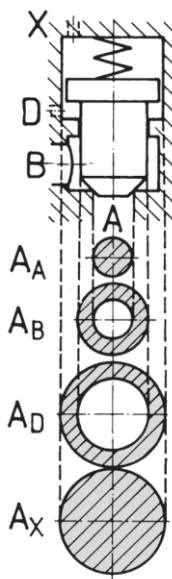

Reference Surface A <sub>A</sub>								
	NG16	NG25	NG32	NG40	NG50	NG63	NG80	NG100
<b>Cones S and T</b>								
Stroke mm	6,5	12,5	15,0	15,0	20	30,0	30,0	35,5
A <sub>A</sub> mm <sup>2</sup>	123	227	452	804	1590	2642	3848	5675
A <sub>A</sub> (Ref)								
A <sub>B</sub>	0,64	0,67	0,56	0,41	0,49	0,46	0,47	0,68
A <sub>D</sub>	0,92	1,04	0,95	1,03	0,93	0,95	1,00	0,77
A <sub>X</sub>	2,56	2,71	2,51	2,44	2,42	2,41	2,47	2,45
<b>Cone X</b>								
Stroke mm	6,5	12,5	15,0	15,0	20,0	30,0	30,0	35,5
A <sub>A</sub> mm <sup>2</sup>	201	380	707	1257	2376	3848	5674	9503
A <sub>A</sub> (Ref)								
A <sub>B</sub>	—	—	—	—	—	—	—	—
A <sub>D</sub>	0,56	0,62	0,61	0,73	0,62	0,65	0,68	0,46
A <sub>X</sub>	1,56	1,62	1,61	1,73	1,62	1,65	1,68	1,46

$\Delta p$ -Q-Diagrams

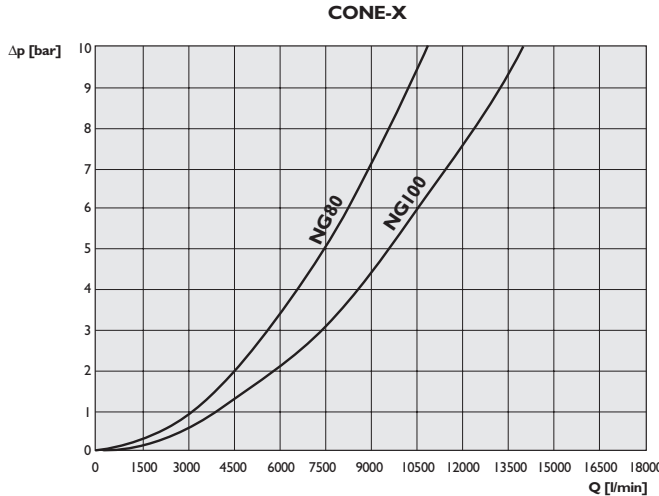
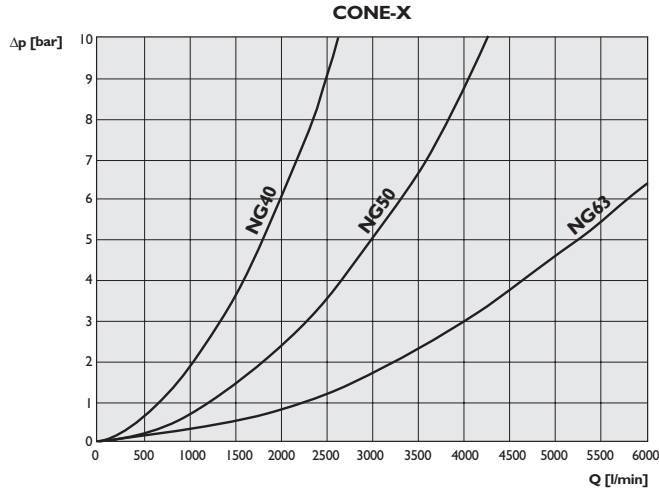
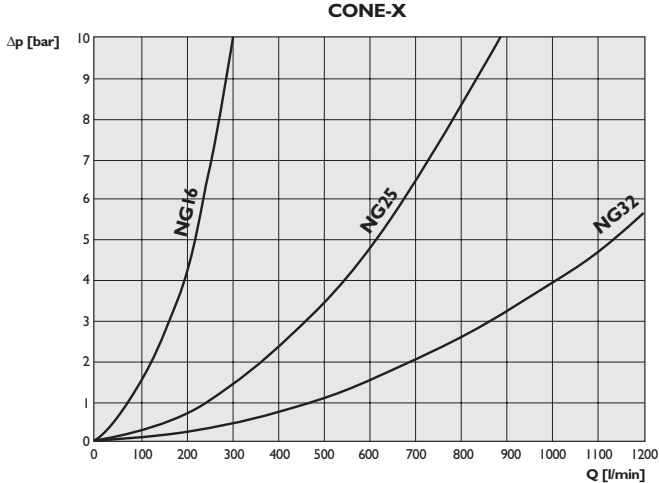

Measuring conditions: activ opened, Oil viscosity 35 mm<sup>2</sup>/s, oil temperature 50° C.

## Δp-Q-Diagrams

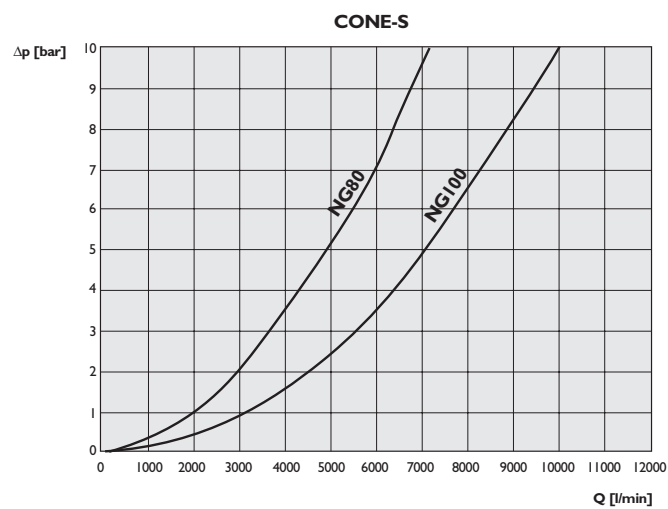
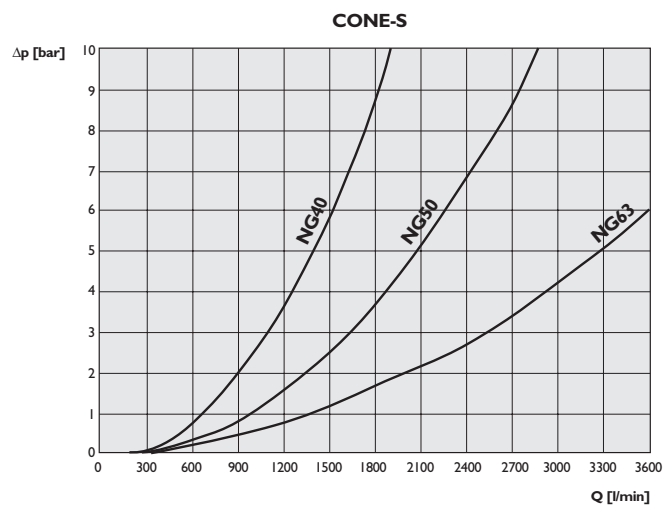
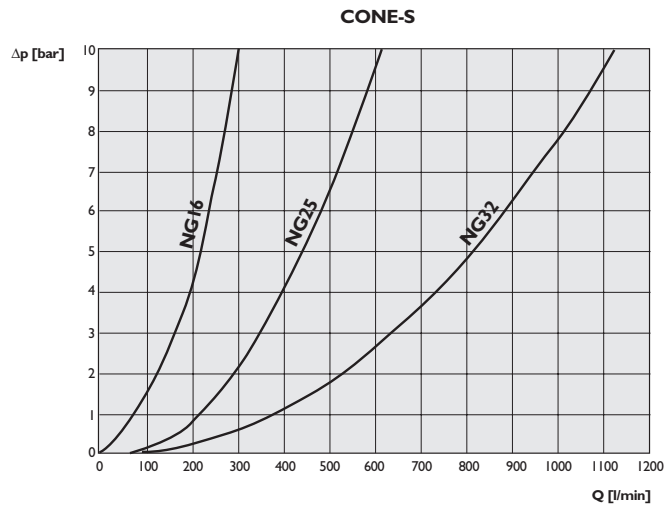

Measuring conditions: activ opened, Oil viscosity 35 mm<sup>2</sup>/s, oil temperature 50° C.



## Δp-Q-Diagrams

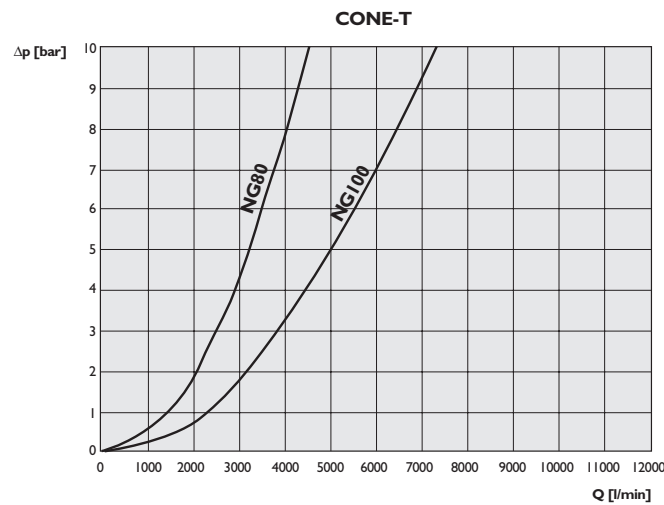
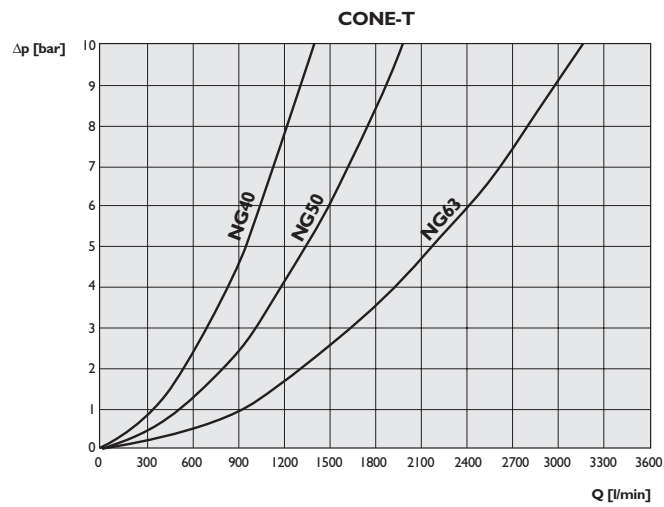
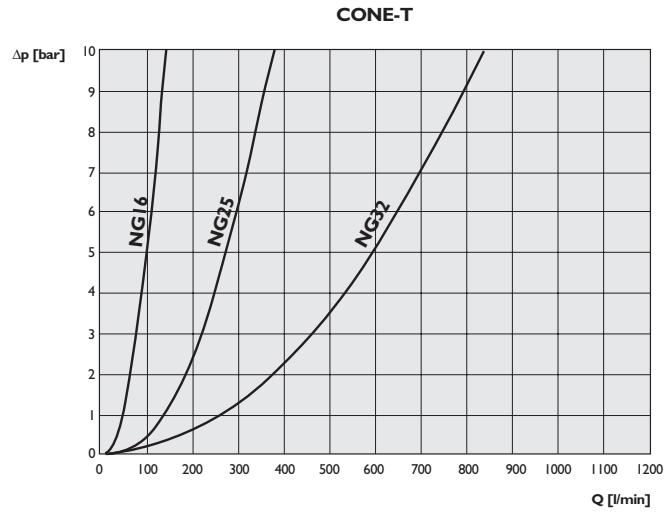

Measuring conditions: activ opened, Oil viscosity 35 mm<sup>2</sup>/s, oil temperature 50° C.

# Standard Models

## X-Cone for Directional Control

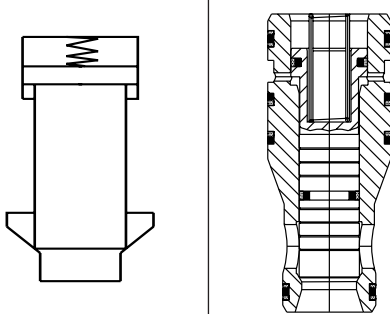
Symbol	Function	Size NG [mm]	Weight kg	Spring Rating bar	Part Designation	Part Number
		16	0,4	2,0	N-CHE16A6XT	XCB10867-000N00
				4,0	N-CHE16A6XU	XCB10868-000N00
				6,0	N-CHE16A6XV	XCB10869-000N00
		25	0,8	2,0	N-CHE25A6XT	XCB10879-000N00
				4,0	N-CHE25A6XU	XCB10880-000N00
				6,0	N-CHE25A6XV	XCB10881-000N00
		32	1,5	2,0	N-CHE32A6XT	XCB10887-000N00
				4,0	N-CHE32A6XU	XCB10888-000N00
		40	3,2	2,0	N-CHE40A6XT	XCB11105-000N00
4,0	N-CHE40A6XU			XCB11106-000N00		
50	5,5	2,0	N-CHE50A6XT	XCB10902-000N00		
		4,0	N-CHE50A6XU	XCB10903-000N00		
63	11,2	2,0	N-CHE63A6XT	XCB10911-000N00		
		4,0	N-CHE63A6XU	XCB10912-000N00		
80	24,1	2,0	N-CHE80A6XT	XCB11161-000N00		
		4,0	N-CHE80A6XU	XCB11162-000N00		
100	39,2	2,0	N-CHE100A6XT	XCB10924-000N00		
		4,0	N-CHE100A6XU	XCB11026-000N00		

## S-Cone for Directional Control

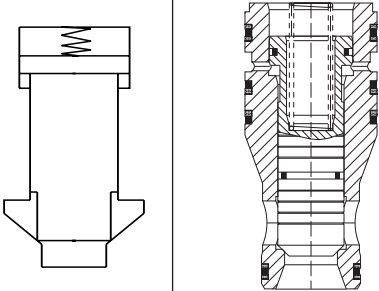
Symbol	Function	Size NG [mm]	Weight kg	Spring Rating bar	Part Designation	Part Number
		16	0,4	2,0	N-CHE16A6ST	XEB10871-000N00
				4,0	N-CHE16A6SU	XEB10872-000N00
				6,0	N-CHE16A6SV	XEB10873-000N00
		25	0,8	2,0	N-CHE25A6ST	XCB10002-000N00
				4,0	N-CHE25A6SU	XCB10003-000N00
				6,0	N-CHE25A6SV	XCB10004-000N00
		32	1,5	2,0	N-CHE32A6ST	XCB10890-000N00
				4,0	N-CHE32A6SU	XCB10891-000N00
		40	3,2	2,0	N-CHE40A6ST	XCB10896-000N00
4,0	N-CHE40A6SU			XCB10897-000N00		
50	5,5	2,0	N-CHE50A6ST	XCB10905-000N00		
		4,0	N-CHE50A6SU	XCB10906-000N00		
63	11,2	2,0	N-CHE63A6ST	XCB10914-000N00		
		4,0	N-CHE63A6SU	XCB10915-000N00		
80	24,1	2,0	N-CHE80A6ST	XCB10920-000N00		
		4,0	N-CHE80A6SU	XCB11078-000N00		
100	39,2	2,0	N-CHE100A6ST	XCB10926-000N00		
		4,0	N-CHE100A6SU	XCB11027-000N00		

# Standard Models

## T-Cone for Directional Control

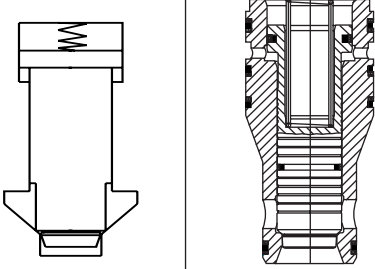
Symbol	Function	Size NG [mm]	Weight kg	Spring Rating bar	Part Designation	Part Number
		16	0,4	2,0	N-CHE16A6TT	XCBI0875 -000N00
				4,0	N-CHE16A6TU	XCBI0876 -000N00
				6,0	N-CHE16A6TV	XCBI0877 -000N00
		25	0,8	2,0	N-CHE25A6TT	XCBI0883 -000N00
				4,0	N-CHE25A6TU	XCBI0884 -000N00
				6,0	N-CHE25A6TV	XCBI0885 -000N00
		32	1,5	2,0	N-CHE32A6TT	XCBI0893 -000N00
				4,0	N-CHE32A6TU	XCBI0894 -000N00
		40	3,2	2,0	N-CHE40A6TT	XCBI0899 -000N00
4,0	N-CHE40A6TU			XCBI0900 -000N00		
50	5,5	2,0	N-CHE50A6TT	XCBI0908 -000N00		
		4,0	N-CHE50A6TU	XCBI0909 -000N00		
63	11,2	2,0	N-CHE63A6TT	XCBI0917 -000N00		
		4,0	N-CHE63A6TU	XCBI0918 -000N00		
80	24,1	2,0	N-CHE80A6TT	XCBI0922 -000N00		
		4,0	N-CHE80A6TU	XCBI1079 -000N00		
100	39,2	2,0	N-CHE100A6TT	XCBI1405 -000N00		
		4,0	N-CHE100A6TU	XCBI1406 -000N00		

## Covers

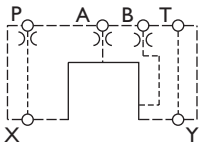
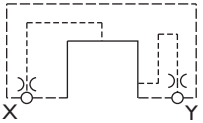
Symbol	Function	Size NG [mm]	Weight lb (kg)	Part Designation	Part Number
	<p>RHI</p> <p>Normally Open or Normally Closed</p>	16	4,0	N-CCE16A6RH1X06	XEB14151-000N01
		25	6,0	N-CCE25A6RH1X06	XEB13343-000N01
		32	8,0	N-CCE32A6RH1X06	XEB12705-000N01
		40	13,0	N-CCE40A6RH1X06	XEB13558-000N01
		50	21,0	N-CCE50A6RH1X10	XEB12603-000N01
		63	39,0	N-CCE63A6RH1X10	XEB13861-000N01
		80	57,0	N-CCE80A6RH1X10	XEB13959-000N01
	<p>RH3</p> <p>Externally Piloted</p>	16	2,0	N-CCE16A6RH3X	XEB14065-000N01
		25	4,0	N-CCE25A6RH3X	XEB14150-000N01
		32	6,0	N-CCE32A6RH3X	XEB13410-000N01
		40	10,0	N-CCE40A6RH3X	XEB13287-000N01
		50	18,0	N-CCE50A6RH3X	XEB12923-000N01
		63	36,0	N-CCE63A6RH3X	XEB14463-000N01
		80	57,0	N-CCE80A6RH3X	XEB13462-000N01
100	60,0	N-CCE100A6RH3X	XEB14040-000N01		

# Typical Orifice Characteristics

The function and switching velocity of a cartridge-valve can be influenced by changes in the metering-in and metering-out flow through the pilot lines. This could be realized by changing mounting orifices as required.

The following diagram should be used for selecting the correct orifice diameter.

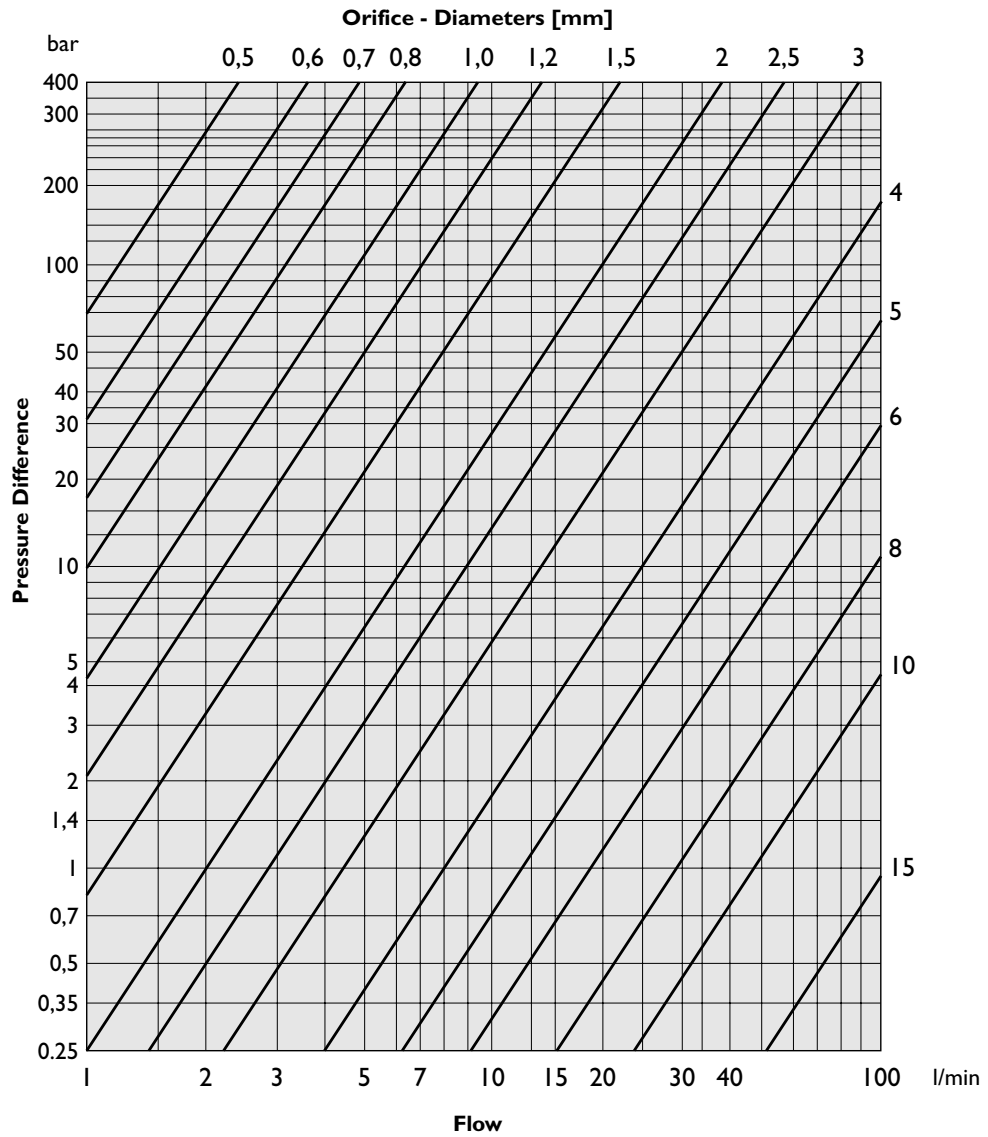

Viscosity :  $35 \text{ mm}^2 \cdot \text{s}^{-1}$  [cSt]

Oil temperature :  $50^\circ\text{C}$

## Hydraulically Operated Valves

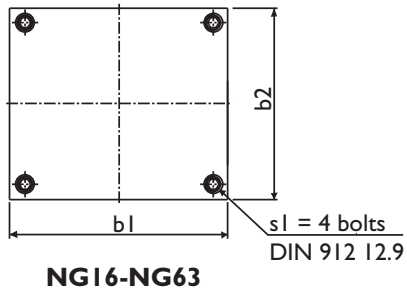
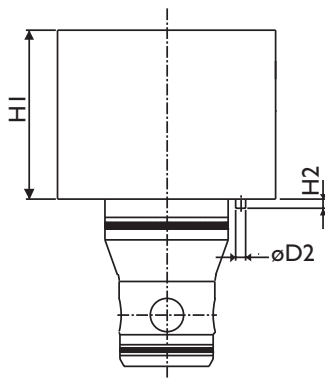
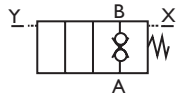

Dimensions mm		NG16	NG25	NG32	NG40	NG50	NG63
H1		65	65	80	80	120	140
H2		5	5	5	5	6	6
D2		5	5	5	5)	6	6
b1		65	85	102	125	140	180
b2		65	85	102	125	140	180
s1	UNC	$5/16" \times 23/4"$	$1/2" \times 23/4"$	$5/8" \times 31/4"$	$3/4" \times 31/2"$	$3/4" \times 5.0"$	$11/4" \times 6.0"$
	Metric	M8X70	M12X65	M16X80	M20X90	M20X120	M30X150
Tightening Torque	ftlb	23	75	225	413	413	1350
	Nm	30	100	300	550	550	1800

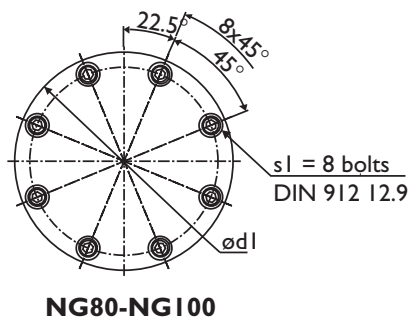

Dimensions mm		NG80	NG100
d1		250	300
H1		150	160
H2		6	6
D2		8	8
s1	UNC	$1" \times 61/2"$	$11/4" \times 61/2"$
	Metric	M24X150	M30X160
Tightening Torque	ftlb	675	1350
	Nm	900	1800

Note: Fastening screws are not part of the delivery.

# Dimensions

## Solenoid Operated Valves

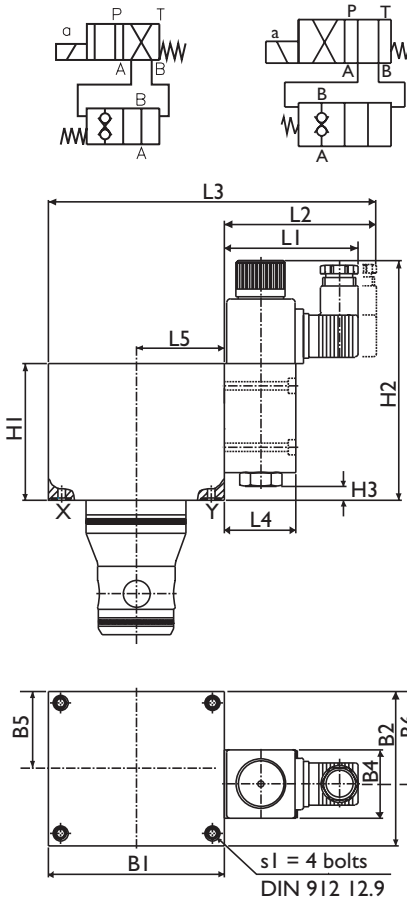

**NG16-NG63**

Dimensions mm		NG16	NG25	NG32	NG40	NG50	NG63
H1		90	90	90	90	120	140
H2		166	166	166	166	228	228
H3		8	8	8	8	5	5
L1		93	93	93	93	120	120
L2		105	105	105	105	132	132
L3		190	205	221	251	292	336
L4		6	46	46	46	96	96
L5		42,5	50	58	73	80	100
la*		y	y	y	y	y	y
B1		85	100	116	146	160	200
B2		65	85	100	125	140	180
B4		46	46	46	46	70	70
B5		32,5	42,5	50	62,5	70	90
B6		32,5	42,5	60,4	62,5	71,6	90
s1	UNC	$\frac{5}{16}'' \times 3\frac{1}{2}''$	$\frac{1}{2}'' \times 3\frac{3}{4}''$	$\frac{5}{8}'' \times 3\frac{3}{4}''$	$\frac{3}{4}'' \times 4''$	$\frac{3}{4}'' \times 4\frac{3}{4}''$	$1\frac{1}{4}'' \times 6,0''$
	Metric	M8X90	M12X90	M16X90	M20X100	M20X130	M30X150
Tightening Torque	ft lb	23	75	225	413	413	1350
	Nm	30	100	300	550	550	1800

\*la = Mounted side of pilot valve

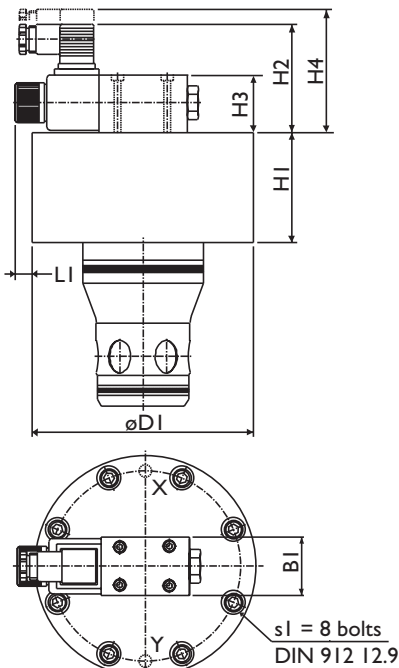

**NG80-NG100**

Dimensions in (mm)		NG80	NG100
D1		250	300
H1		150	160
H2		111	111
H3		70	70
H4		123	123
L1		44	19
B1		70	70
s1	UNC	$1'' \times 6\frac{1}{2}''$	$1\frac{1}{4}'' \times 6\frac{1}{2}''$
	Metric	M24X150	M30X160
Tightening Torque	ft lb	675	1350
	Nm	900	1800

Note: Fastening screws are not part of the delivery.



## INSTALLATION DIMENSIONS

In Accordance with ISO 7386:1989-08

### Cartridge Cavity

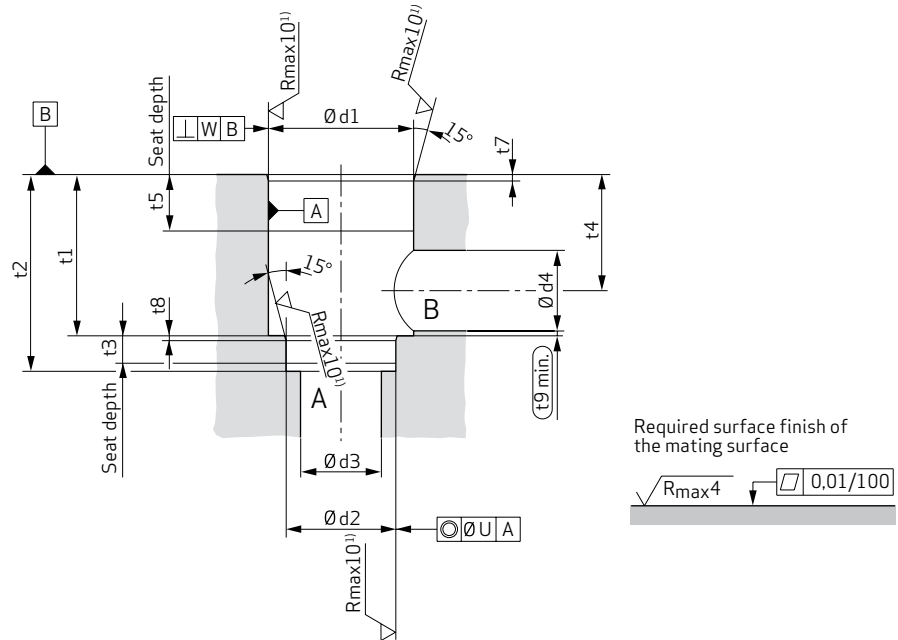

1) Recommendation deviates from the standard

### Bolt and Port Pattern

Sizes 16 to 63

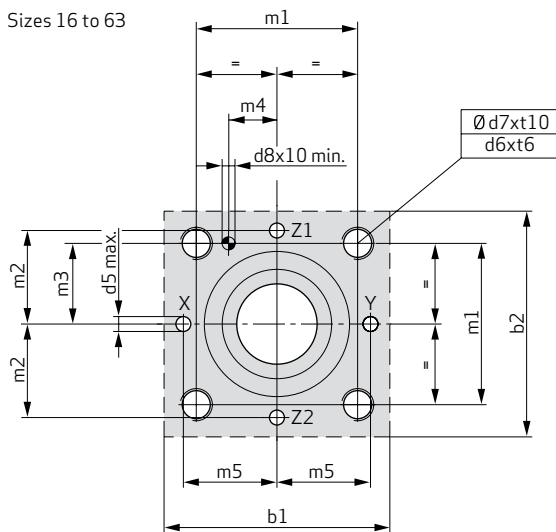

Sizes 80 and 100

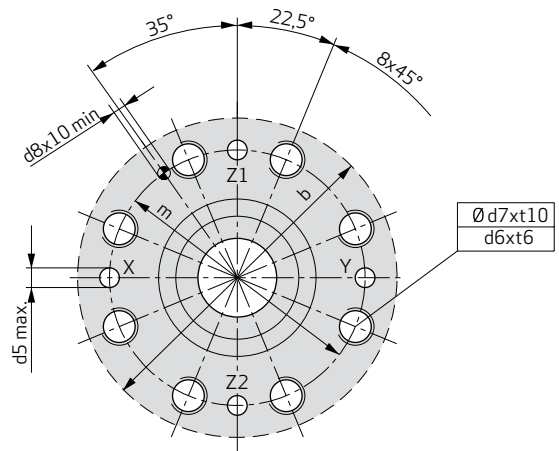

## INSTALLATION DIMENSIONS

In Accordance with ISO 7386:1989-08

ND	16 mm	25 mm	32 mm	40 mm	50 mm	63 mm
<b>b1</b>	65 (2.56)	85 (3.35)	102 (4.02)	125 (4.92)	140 (5.51)	200 (7.87)
<b>b2</b>	65 (2.56)	85 (3.35)	102 (4.02)	125 (4.92)	140 (5.51)	180 (7.09)
<b>d1<sup>H7/1</sup></b>	32 (1.26)	45 (1.77)	60 (2.36)	75 (2.95)	90 (3.54)	120 (4.72)
<b>d2<sup>H7/1</sup></b>	25 (0.98)	34 (1.34)	45 (1.77)	55 (2.17)	68 (2.68)	90 (3.54)
<b>d3</b>	16 (0.63)	25 (0.98)	32 (1.26)	40 (1.57)	50 (1.97)	63 (2.48)
<b>d4</b>	16 (0.63)	25 (0.98)	32 (1.26)	40 (1.57)	50 (1.97)	63 (2.48)
<b>d4<sub>max.</sub><sup>1)</sup></b>	25 (0.98)	32 (1.26)	40 (1.57)	50 (1.97)	63 (2.48)	80 (3.15)
<b>d5<sub>max.</sub></b>	4 (0.16)	6 (0.24)	8 (0.31)	10 (0.39)	10 (0.39)	12 (0.47)
<b>d6</b>	M8	M12	M16	M20	M20	M30
<b>d7</b>	6.8 (0.27)	10.2 (0.4)	14 (0.55)	17.5 (0.69)	17.5 (0.69)	26.5 (1.04)
<b>d8<sup>H13</sup></b>	4 (0.16)	6 (0.24)	6 (0.24)	6 (0.24)	8 (0.31)	8 (0.31)
<b>m1<sup>±0.2</sup></b>	46 (1.81)	58 (2.28)	70 (2.76)	85 (3.35)	100 (3.94)	125 (4.92)
<b>m2<sup>±0.2</sup></b>	25 (0.98)	33 (1.3)	41 (1.61)	50 (1.97)	58 (2.28)	75 (2.95)
<b>m3<sup>±0.2</sup></b>	23 (0.91)	29 (1.14)	35 (1.38)	42.5 (1.67)	50 (1.97)	62.5 (2.46)
<b>m4<sup>±0.2</sup></b>	10.5 (0.41)	16 (0.63)	17 (0.67)	23 (0.91)	30 (1.18)	38 (1.5)
<b>m5<sup>±0.2</sup></b>	25 (0.98)	33 (1.3)	41 (1.61)	50 (1.97)	58 (2.28)	75 (2.95)
<b>t1<sup>±0.1</sup></b>	43 (1.69)	58 (2.28)	70 (2.76)	87 (3.43)	100 (3.94)	130 (5.12)
<b>t2<sup>±0.1</sup></b>	56 (2.2)	72 (2.83)	85 (3.35)	105 (4.13)	122 (4.8)	155 (6.1)
<b>t3</b>	11 (0.43)	12 (0.47)	13 (0.51)	15 (0.59)	17 (0.67)	20 (0.79)
<b>t4</b>	34 (1.34)	44 (1.73)	52 (2.05)	64 (2.52)	72 (2.83)	95 (3.74)
<b>t4 bei d4<sub>max.</sub><sup>1)</sup></b>	29.5 (1.16)	40.5 (1.59)	48 (1.89)	59 (2.32)	65.5 (2.58)	86.5 (3.41)
<b>t5</b>	20 (0.79)	30 (1.18)	30 (1.18)	30 (1.18)	35 (1.38)	40 (1.57)
<b>t6</b>	14 (0.55)	20 (0.79)	26 (1.02)	33 (1.3)	33 (1.3)	50 (1.97)
<b>t7</b>	2 (0.08)	2.5 (0.1)	2.5 (0.1)	3 (0.12)	4 (0.16)	4 (0.16)
<b>t8</b>	2 (0.08)	2.5 (0.1)	2.5 (0.1)	3 (0.12)	3 (0.12)	4 (0.16)
<b>t9</b>	0.5 (0.02)	1.0 (0.04)	1.5 (0.06)	2.5 (0.1)	2.5 (0.1)	3 (0.12)
<b>t10</b>	17 (0.67)	24 (0.94)	31 (1.22)	38 (1.5)	38 (1.5)	56 (2.2)
<b>U</b>	0.03 (0)	0.03 (0)	0.03 (0)	0.05 (0)	0.05 (0)	0.05 (0)
<b>W</b>	0.05 (0)	0.05 (0)	0.1 (0)	0.1 (0)	0.1 (0)	0.2 (0.01)

ND	80 mm	100 mm
<b>b<sub>max.</sub></b>	250 (9.84)	300 (11.81)
<b>d1<sup>H7/1</sup></b>	145 (5.71)	180 (7.09)
<b>d2<sup>H7/1</sup></b>	110 (4.33)	135 (5.31)
<b>d3</b>	80 (3.15)	100 (3.94)
<b>d4</b>	80 (3.15)	100 (3.94)
<b>d4<sub>max.</sub><sup>1)</sup></b>	100 (3.94)	125 (4.92)
<b>d5<sub>max.</sub></b>	16 (0.63)	20 (0.79)
<b>d6</b>	M24	M30
<b>d7</b>	21 (0.83)	26.5 (1.04)
<b>d8<sup>H13</sup></b>	10 (0.39)	10 (0.39)
<b>m<sup>±0.3</sup></b>	200 (7.87)	245 (9.65)
<b>t1</b>	175 (6.89)	210 (8.27)
<b>t2<sup>±0.2</sup></b>	205 (8.07)	245 (9.65)
<b>t3</b>	25 (0.98)	29 (1.14)
<b>t4</b>	130 (5.12)	155 (6.1)
<b>t4 bei d4<sub>max.</sub><sup>1)</sup></b>	120 (4.72)	142.5 (5.61)
<b>t5</b>	40 (1.57)	50 (1.97)
<b>t6</b>	39 (1.54)	50 (1.97)
<b>t7</b>	5 (0.2)	5 (0.2)
<b>t8</b>	5 (0.2)	5 (0.2)
<b>t9</b>	3 (0.12)	5 (0.2)
<b>t10</b>	45 (1.77)	56 (2.2)
<b>U</b>	0.05 (0)	0.05 (0)
<b>W</b>	0.2 (0.01)	0.2 (0.01)

1) Recommendation deviates from the standard

Note: Dimensions in mm (in)

## Active Cartridge (w/o cover)

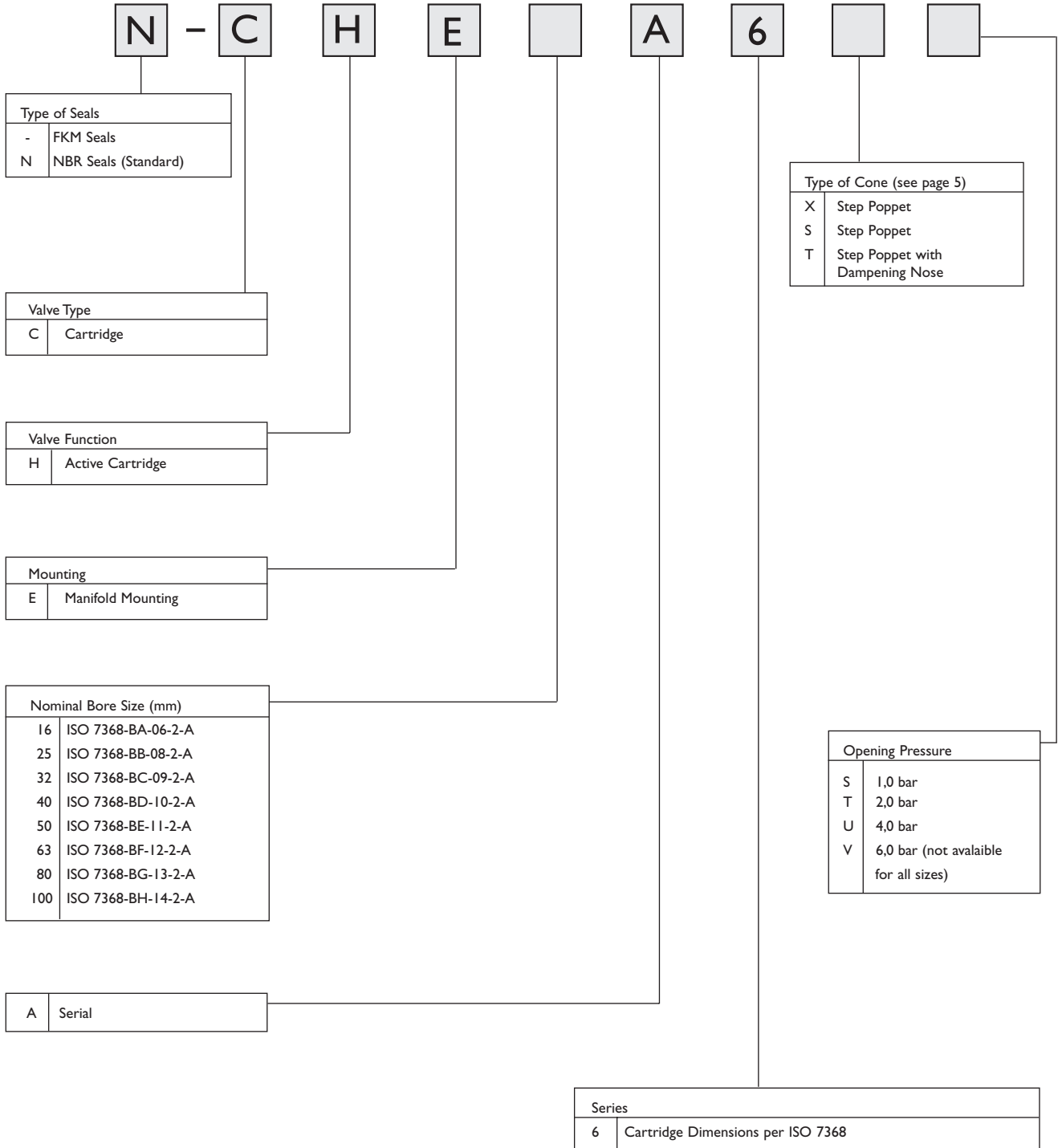

# Ordering Information

## Active Cartridge Covers

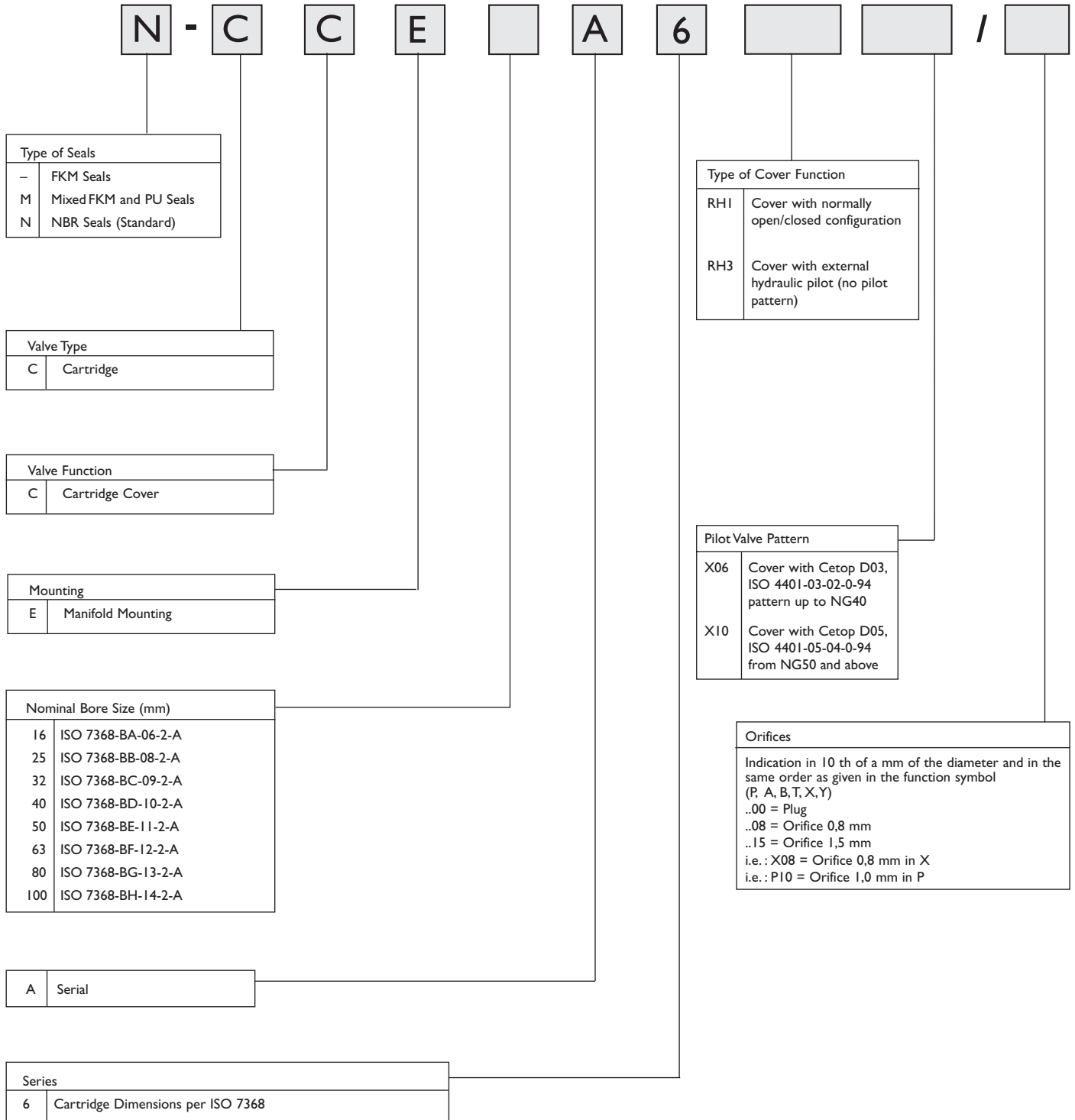

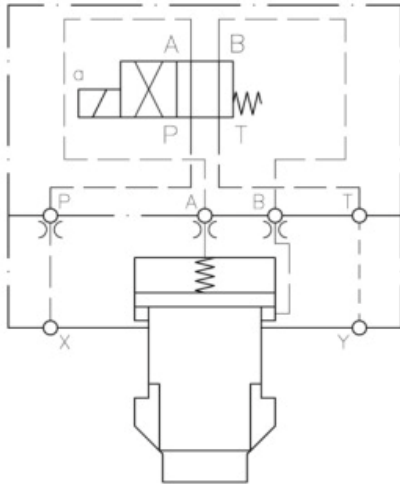

**(Normally Closed - Energize solenoid to open)**

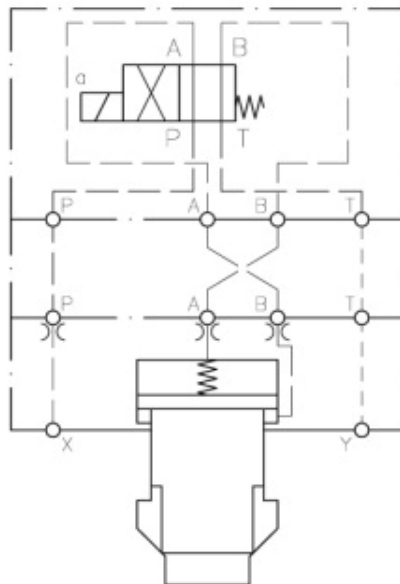

**(Normally Open - Energize solenoid to close)**

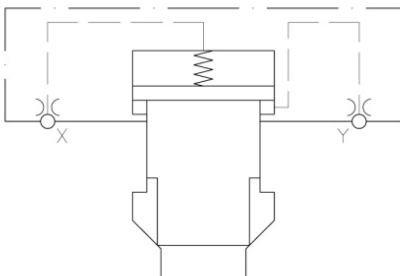

**(externally hydraulically operated)**

# Spare Parts

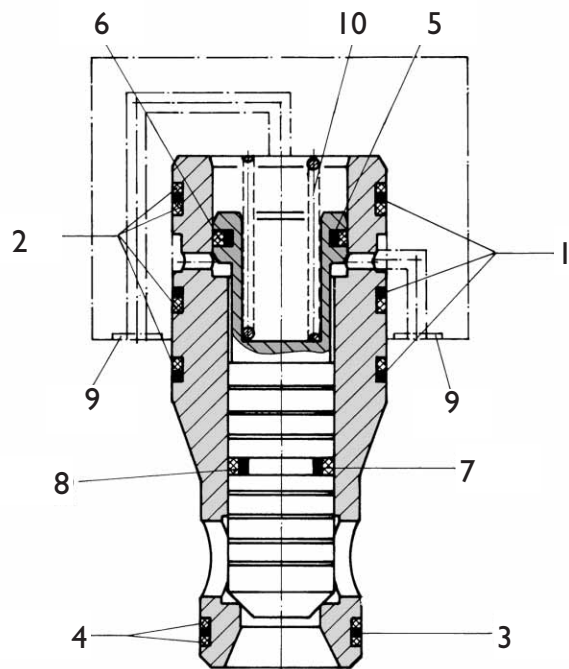

Pos.	Designation		Order Number							
			NG16	NG25	NG32	NG40	NG50	NG63	NG80	NG100
	Seal Kit	XEB	12240	12241	12242	12243	12244	12245	12246	12247
	<b>Springs</b>									
10	Spring S - 1,0 bar	XEF	10006	10013	10138	10106	10037	10044	10051	10058
10	Spring T - 2,0 bar	XEF	10007	10014	10140	10105	10038	10045	10052	10059
10	Spring U - 4,0 bar	XEF	10008	10015	10191	10104	10173	10046	10052 10250	10059 10253
10	Spring V - 6,0 bar	XEF	10009	10015 10016	—	—	—	—	—	—

Order examples:

O-Ring Item 5 for NG25

Order number: X980-02116

Spring 2,0 bar Item 10 for NG25

Order number: XEF10014



# TAKE A CLOSER LOOK.

Moog designs a range of motion control products that complement the performance of those featured in this catalog. Visit our website for more information and contact the Moog facility nearest you.

Argentina  
+54 11 4326 5916  
info.argentina@moog.com

India  
+91 80 4057 6666  
info.india@moog.com

Singapore  
+65 677 36238  
info.singapore@moog.com

Australia  
+61 3 9561 6044  
info.australia@moog.com

Ireland  
+353 21 451 9000  
info.ireland@moog.com

South Africa  
+27 12 653 6768  
info.southafrica@moog.com

Brazil  
+55 11 3572 0400  
info.brazil@moog.com

Italy  
+39 0332 421 111  
info.italy@moog.com

Spain  
+34 902 133 240  
info.spain@moog.com

Canada  
+1 716 652 2000  
info.canada@moog.com

Japan  
+81 46 355 3767  
info.japan@moog.com

Sweden  
+46 31 680 060  
info.sweden@moog.com

China  
+86 21 2893 1600  
info.china@moog.com

Korea  
+82 31 764 6711  
info.korea@moog.com

Switzerland  
+41 71 394 5010  
info.switzerland@moog.com

Finland  
+358 10 422 1840  
info.finland@moog.com

Luxembourg  
+352 40 46 401  
info.luxembourg@moog.com

Turkey  
+90 216 663 6020  
info.turkey@moog.com

France  
+33 1 4560 7000  
info.france@moog.com

The Netherlands  
+31 252 462 000  
info.thenetherlands@moog.com

United Kingdom  
+44 (0) 1684 858000  
info.uk@moog.com

Germany  
+49 7031 622 0  
info.germany@moog.com

Norway  
+47 6494 1948  
info.norway@moog.com

USA  
+1 716 652 2000  
info.usa@moog.com

Hong Kong  
+852 2 635 3200  
info.hongkong@moog.com

**[www.moog.com/industrial](http://www.moog.com/industrial)**

Moog is a registered trademark of Moog Inc. and its subsidiaries. All trademarks as indicated herein are the property of Moog Inc. and its subsidiaries.

©2022 Moog Inc. All rights reserved. All changes are reserved.

CHE\_A6-1-EN-2-Way Active Cartridges - CDL66626-001-D-05-2022