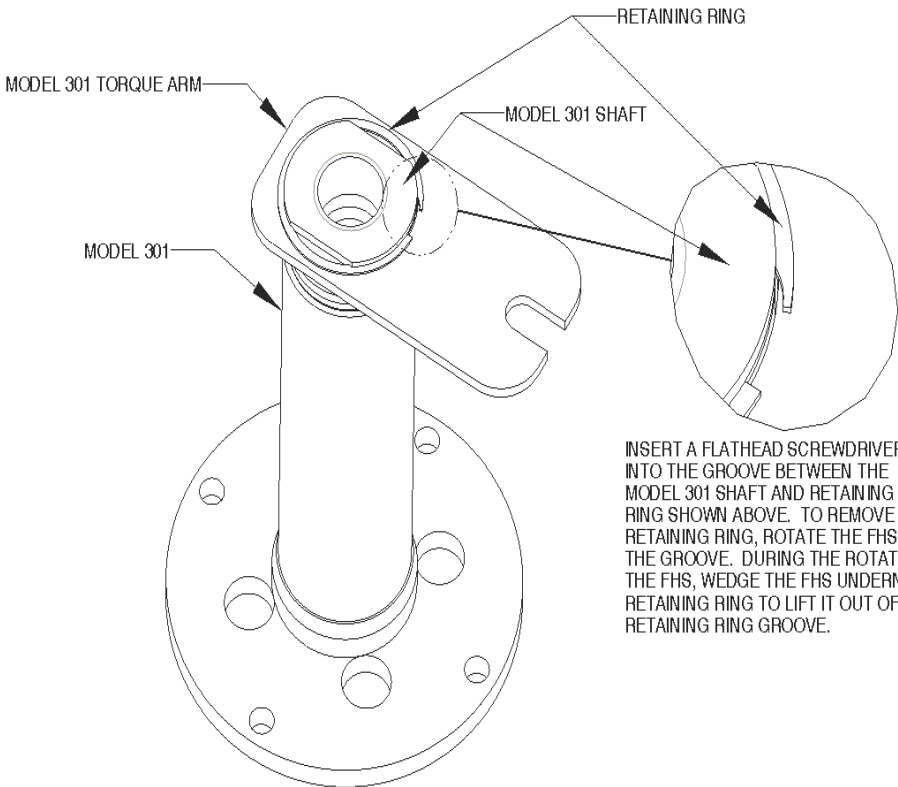
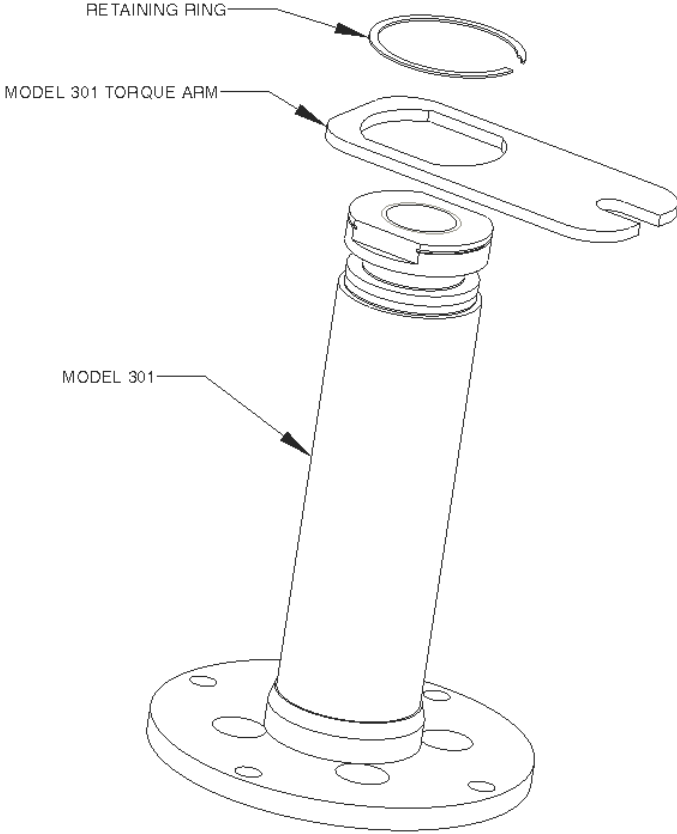

MOOG PROPRIETARY AND CONFIDENTIAL INFORMATION  
THIS TECHNICAL DATA/DRAWING/DOCUMENT CONTAINS INFORMATION THAT IS PROPRIETARY TO, AND IS THE EXPRESS PROPERTY OF MOOG INC., OR MOOG INC. SUBSIDIARIES EXCEPT AS EXPRESSLY GRANTED BY CONTRACT OR BY OPERATION OF LAW AND IS RESTRICTED TO USE BY ONLY MOOG EMPLOYEES AND OTHER PERSONS AUTHORIZED IN WRITING BY MOOG OR AS EXPRESSLY GRANTED BY CONTRACT OR BY OPERATION OF LAW. NO PORTION OF THIS DATA/DRAWING/DOCUMENT SHALL BE REPRODUCED OR DISCLOSED OR COPIED OR FURNISHED IN WHOLE OR IN PART TO OTHERS OR USED BY OTHERS FOR ANY PURPOSE WHATSOEVER EXCEPT AS SPECIFICALLY AUTHORIZED IN WRITING BY MOOG INC. OR MOOG INC. SUBSIDIARY.

Item:	Model 301/AC4598 or AC6200 Integration Checklist	Rev: 1
Focal Doc. No.	700-0586-00	Date: 2013-06-03

#	Instruction	Assembler/ Inspector	Date
1	<b>CAUTION: Prior to integration, both port openings on the model 301 must be covered to prevent contamination of the unit.</b>		
2	<p>Remove the retaining ring from the model 301 shaft.</p> 		

MOOG PROPRIETARY AND CONFIDENTIAL INFORMATION  
 THIS TECHNICAL DATA/DRAWING/DOCUMENT CONTAINS INFORMATION THAT IS PROPRIETARY TO, AND IS THE EXPRESS PROPERTY OF MOOG INC., OR MOOG INC. SUBSIDIARIES EXCEPT AS EXPRESSLY GRANTED BY CONTRACT OR BY OPERATION OF LAW AND IS RESTRICTED TO USE BY ONLY MOOG EMPLOYEES AND OTHER PERSONS AUTHORIZED IN WRITING BY MOOG OR AS EXPRESSLY GRANTED BY CONTRACT OR BY OPERATION OF LAW. NO PORTION OF THIS DATA/DRAWING/DOCUMENT SHALL BE REPRODUCED OR DISCLOSED OR COPIED OR FURNISHED IN WHOLE OR IN PART TO OTHERS OR USED BY OTHERS FOR ANY PURPOSE WHATSOEVER EXCEPT AS SPECIFICALLY AUTHORIZED IN WRITING BY MOOG INC. OR MOOG INC. SUBSIDIARY.

#	Instruction	Assembler/ Inspector	Date
3	<p>Remove the torque arm from the model 301. The torque arm should slide off with ease once the retaining ring is removed.</p> 		

MOOG PROPRIETARY AND CONFIDENTIAL INFORMATION  
 THIS TECHNICAL DATA/DRAWING/DOCUMENT CONTAINS INFORMATION THAT IS PROPRIETARY TO, AND IS THE EXPRESS PROPERTY OF MOOG INC., OR MOOG INC. SUBSIDIARIES EXCEPT AS EXPRESSLY GRANTED BY CONTRACT OR BY OPERATION OF LAW AND IS RESTRICTED TO USE BY ONLY MOOG EMPLOYEES AND OTHER PERSONS AUTHORIZED IN WRITING BY MOOG OR AS EXPRESSLY GRANTED BY CONTRACT OR BY OPERATION OF LAW. NO PORTION OF THIS DATA/DRAWING/DOCUMENT SHALL BE REPRODUCED OR DISCLOSED OR COPIED OR FURNISHED IN WHOLE OR IN PART TO OTHERS OR USED BY OTHERS FOR ANY PURPOSE WHATSOEVER EXCEPT AS SPECIFICALLY AUTHORIZED IN WRITING BY MOOG INC. OR MOOG INC. SUBSIDIARY.

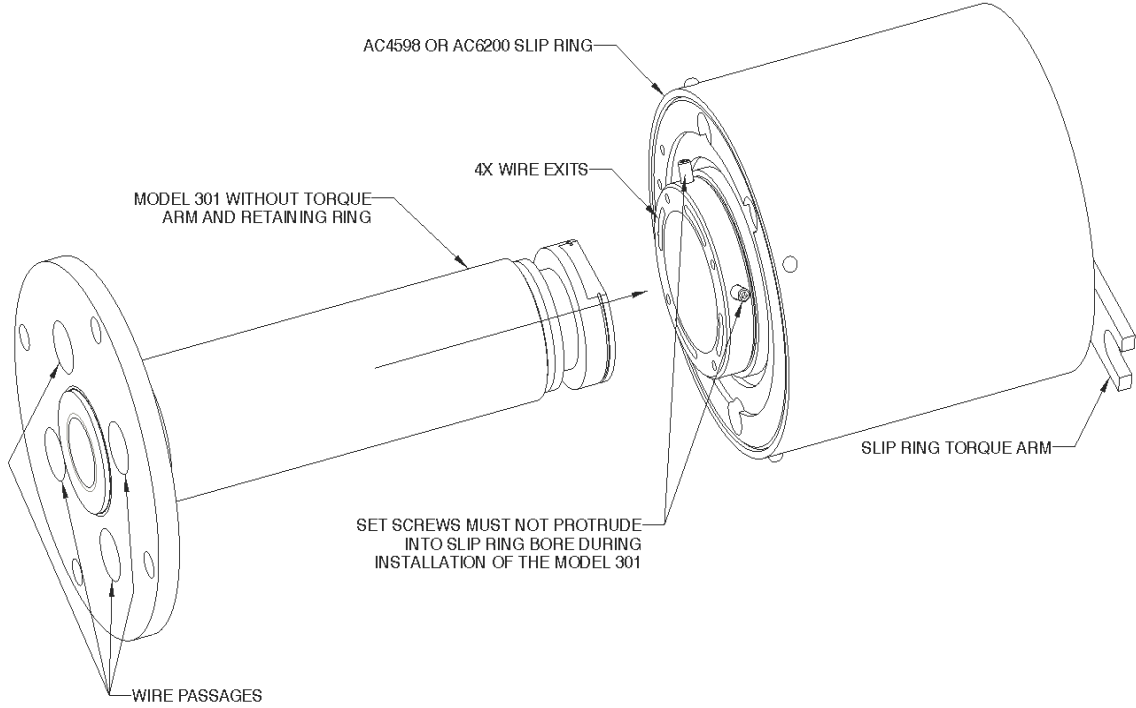
#	Instruction	Assembler/ Inspector	Date
4	<p>Ensure that the set screws of the AC4598 or AC6200 slip ring DO NOT protrude into the bore of the slip ring. Insert the model 301 into the bore of the AC4598 or AC6200 slip ring. Ensure that the model 301 is inserted into the bore on the opposite side to where the torque arm is located on the slip ring. Carefully route the slip ring pigtails through the appropriate wire passage holes on the model 301 flange.</p> 		

MOOG PROPRIETARY AND CONFIDENTIAL INFORMATION  
THIS TECHNICAL DATA/DRAWING/DOCUMENT CONTAINS INFORMATION THAT IS PROPRIETARY TO, AND IS THE EXPRESS PROPERTY OF MOOG INC., OR MOOG INC. SUBSIDIARIES EXCEPT AS EXPRESSLY GRANTED BY CONTRACT OR BY OPERATION OF LAW AND IS RESTRICTED TO USE BY ONLY MOOG EMPLOYEES AND OTHER PERSONS AUTHORIZED IN WRITING BY MOOG OR AS EXPRESSLY GRANTED BY CONTRACT OR BY OPERATION OF LAW. NO PORTION OF THIS DATA/DRAWING/DOCUMENT SHALL BE REPRODUCED OR DISCLOSED OR COPIED OR FURNISHED IN WHOLE OR IN PART TO OTHERS OR USED BY OTHERS FOR ANY PURPOSE WHATSOEVER EXCEPT AS SPECIFICALLY AUTHORIZED IN WRITING BY MOOG INC. OR MOOG INC. SUBSIDIARY.

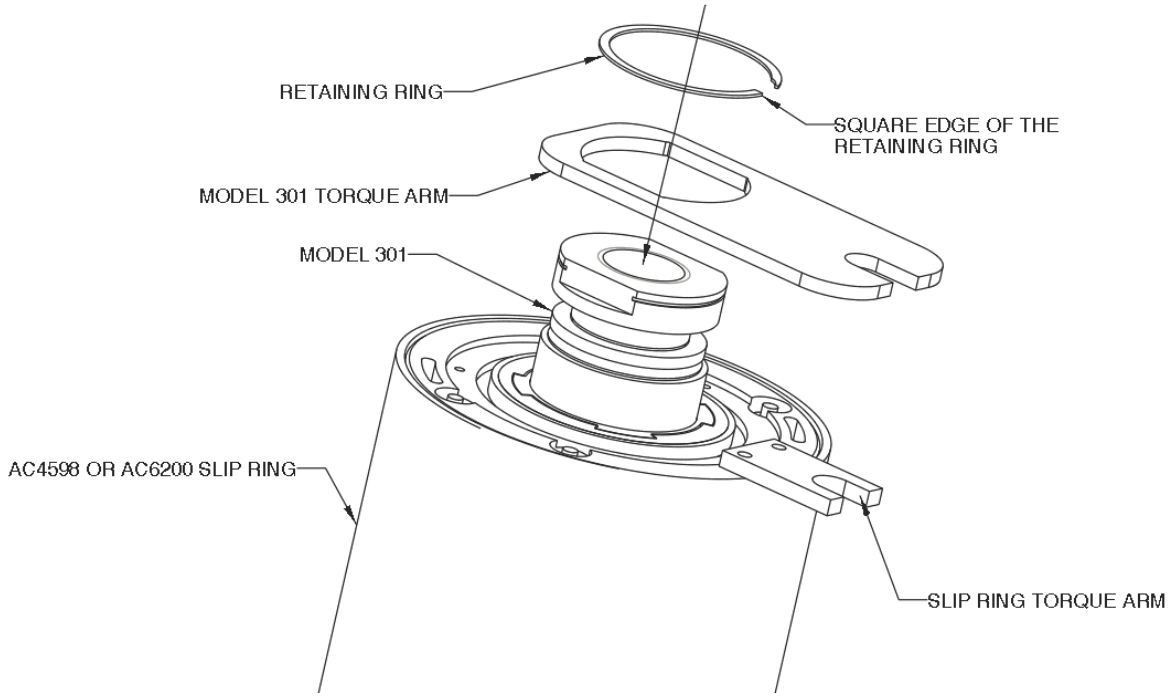
#	Instruction	Assembler/ Inspector	Date
5	<p>Place the torque arm onto the model 301. Then install the retaining ring. To install the retaining ring, start by inserting the square edge of the retaining ring into the retaining ring groove. Gradually work the retaining ring into the groove by stretching it over the shaft and forcing it down into the groove. Note that retaining rings are made to squeeze the ID of a retaining ring groove, so force is required to counteract the spring force of the retaining ring. Orient the retaining ring ends as shown in step 2.</p> 		

MOOG PROPRIETARY AND CONFIDENTIAL INFORMATION  
 THIS TECHNICAL DATA/DRAWING/DOCUMENT CONTAINS INFORMATION THAT IS PROPRIETARY TO, AND IS THE EXPRESS PROPERTY OF MOOG INC., OR MOOG INC. SUBSIDIARIES EXCEPT AS EXPRESSLY GRANTED BY CONTRACT OR BY OPERATION OF LAW AND IS RESTRICTED TO USE BY ONLY MOOG EMPLOYEES AND OTHER PERSONS AUTHORIZED IN WRITING BY MOOG OR AS EXPRESSLY GRANTED BY CONTRACT OR BY OPERATION OF LAW. NO PORTION OF THIS DATA/DRAWING/DOCUMENT SHALL BE REPRODUCED OR DISCLOSED OR COPIED OR FURNISHED IN WHOLE OR IN PART TO OTHERS OR USED BY OTHERS FOR ANY PURPOSE WHATSOEVER EXCEPT AS SPECIFICALLY AUTHORIZED IN WRITING BY MOOG INC. OR MOOG INC. SUBSIDIARY.

#	Instruction	Assembler/ Inspector	Date
6	<p>Align the torque arm of the FRU with the torque arm of the slip ring. Adjust the axial distance between torque arms to the desired distance. Tighten 2x set screw to secure the slip ring shaft to the model 301 FRU.</p> 