

Frameless Permanent Magnet Alternators

Inside Rotor

AG Matrix™ Series



TYPICAL APPLICATIONS

- Auxiliary power generation
- Wind energy
- Onboard power generation for manned and unmanned vehicles

FEATURES

- Compact
- Continuous AC output power from 345 W to over 36 kW
- Double insulated high temp magnet wire minimizes leakage current and provides good thermal resistance
- Stable high temp encapsulation material minimizes movement or working of windings under large temperature variations.
- Rare earth magnets
- High power density
- Large through bores

OPTIONS

- Winding options to adjust the output power and output voltage
- Varying stack lengths from 0.10 to over 30 inches (2.54 to 762 mm)
- Mounting flanges, hubs, mounting holes and connectors may be added as required

The AG Matrix™ Series alternators are used in applications that require high power density. The designs are optimized for maximum output power and maximum efficiency.

Utilizing high energy rare earth magnets and dense slot fills, the AG Series achieves higher AC output power. This provides the highest performance per volume and minimizes the alternators footprint within the system.

The alternators are supplied as a direct drive rotor / stator frameless part set that is directly attached to the load. This form of attachment eliminates backlash and increases stiffness for an optimized direct drive system.

The AG Matrix Series is a family of alternators consisting of a wide range of sizes, outside diameters from 5.25 to 22 inches (133.35 mm to 558.8 mm) with multiple stack sizes and winding options for each diameter.

Along with our standard Matrix alternators, our engineers design custom solutions. If our existing models don't meet your needs, we will tailor them or provide options for a best value solution to meet your exact requirements.

Note: This catalog contains basic marketing information and general part descriptions of Moog Components Group product lines. With respect to the U.S. export regulations, the products described herein are controlled by the U.S. Commerce Department or the U.S. State Department. Contact Moog Components Group for additional detail on the export controls that are applicable to your part.

AG Matrix Series Specifications

SPECIFICATION AND NUMBERING SYSTEM

Part Numbering System Guide

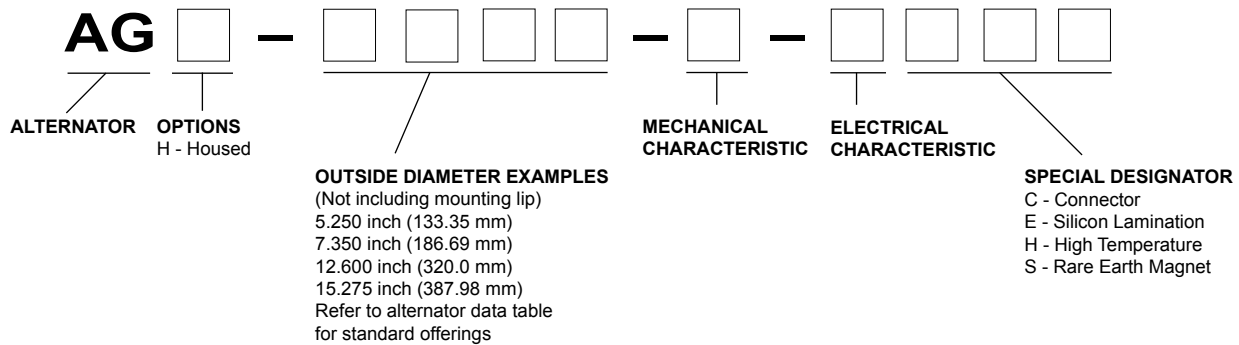

A permanent magnet alternator is a power generating device that produces a sinusoidal output when a mechanical input to its hub or shaft is applied. This device is constructed very much like a brushless motor with the appropriate selection of insulation materials and winding to match the environment and application. Essentially, a permanent magnet alternator is to a brushless motor what a tachometer is to a brush-type motor except that the alternator's application is power generation instead of rate feedback.

Design Considerations

All diameters listed have finished ground lamination surfaces. They can be complemented with rings and hubs for mounting convenience.

If you require a housing that may also include bearings, we can design the entire assembly to meet your mechanical dimensions and performance requirements.

Electrical Considerations

For each mechanical configuration shown, different winding designs to modify AC output voltage, output power or speed can be supplied by Moog Components Group to suit your system requirement. In each case, you have the option of selecting one of the existing designs or specifying a new winding designed to meet your exact requirements.

Mounting Considerations

Since the alternators are normally delivered in kit form, you provide the mounting surfaces and bearings. When you design the mechanics of the mount, be sure to observe these rules:

1. Eccentricities from the inner member mounting surface should not exceed 0.004 inches for rare earth motor designs.
2. The bore of the mounting surface should be perpendicular to the mounting seat within 0.002 inches for rare earth designs.

The following frame sizes represent only a small sampling of the total range manufactured. Consult factory for additional designs. Refer to our online documentation for product updates.

AG-12600 Matirx Series Specifications

AG-12600-()-() SERIES SPECIFICATIONS @ 25°C

Part Number	Continuous Rated Power (W)	Rated Speed (RPM)	Voltage (V rms)	Current (Amps rms)	Efficiency (%)	Input Torque at Rated Speed lb.ft (N.m)	Weight lb (Kg)	OD* Inches (mm)	ID Inches (mm)	Length "A" Inches (mm)	Length "B" Inches (mm)
AG-12600-A-1ES	966	250	256	2.18	79	35.8 (48.54)	21.0 (9.53)	12.60 (320.0)	8.75 (222.25)	1.6 (40.64)	1.05 (26.67)
AG-12600-A-2ES	3874	800	280	7.98	90	37.7 (51.12)	21.0 (9.53)	12.60 (320.0)	8.75 (222.25)	1.6 (40.64)	1.05 (26.67)
AG-12600-B-1ES	2149	250	265	4.68	85	73.0 (99.99)	36.0 (16.33)	12.60 (320.0)	8.75 (222.25)	2.6 (66.04)	2.075 (52.71)
AG-12600-B-2ES	7998	800	285	163.17	90	76.8 (104.14)	36.0 (16.33)	12.60 (320.0)	8.75 (222.25)	2.6 (66.04)	2.075 (52.71)
AG-12600-C-1ES	3681	250	283	7.27	86	120.0 (162.72)	51.0 (23.13)	12.60 (320.0)	8.75 (222.25)	3.6 (91.44)	3.10 (78.74)
AG-12600-C-2ES	12281	800	301	22.75	91	118.0 (160.01)	51.0 (23.13)	12.60 (320.0)	8.75 (222.25)	3.6 (91.44)	3.10 (78.74)
AG-12600-D-1ES	4737	250	278	9.82	87	154.0 (208.82)	65.0 (29.48)	12.60 (320.0)	8.75 (222.25)	4.6 (116.84)	4.125 (104.775)
AG-12600-D-2ES	16388	800	284	33.02	91	157.0 (212.89)	65.0 (29.48)	12.60 (320.0)	8.75 (222.25)	4.6 (116.84)	4.125 (104.775)
AG-12600-E-1ES	5966	250	282	12.23	88	193.0 (261.71)	80.0 (36.29)	12.60 (320.0)	8.75 (222.25)	5.6 (142.24)	5.15 (130.81)
AG-12600-E-2ES	20941	800	297	40.31	91	201.0 (272.56)	80.0 (36.29)	12.60 (320.0)	8.75 (222.25)	5.6 (142.24)	5.15 (130.81)
AG-12600-F-1ES	7049	250	280	14.52	89	227.0 (307.81)	96.0 (43.55)	12.60 (320.0)	8.75 (222.25)	6.6 (167.64)	6.2 (157.48)
AG-12600-F-2ES	23986	800	277	49.27	91	230.0 (311.88)	96.0 (43.55)	12.60 (320.0)	8.75 (222.25)	6.6 (167.64)	6.2 (157.48)

*Dimensions do not reflect mounting lip.
Stack lengths from 0.25 to 25.00 inches (6.35 to 635 mm)

AG-12600-()-() Outline Drawing

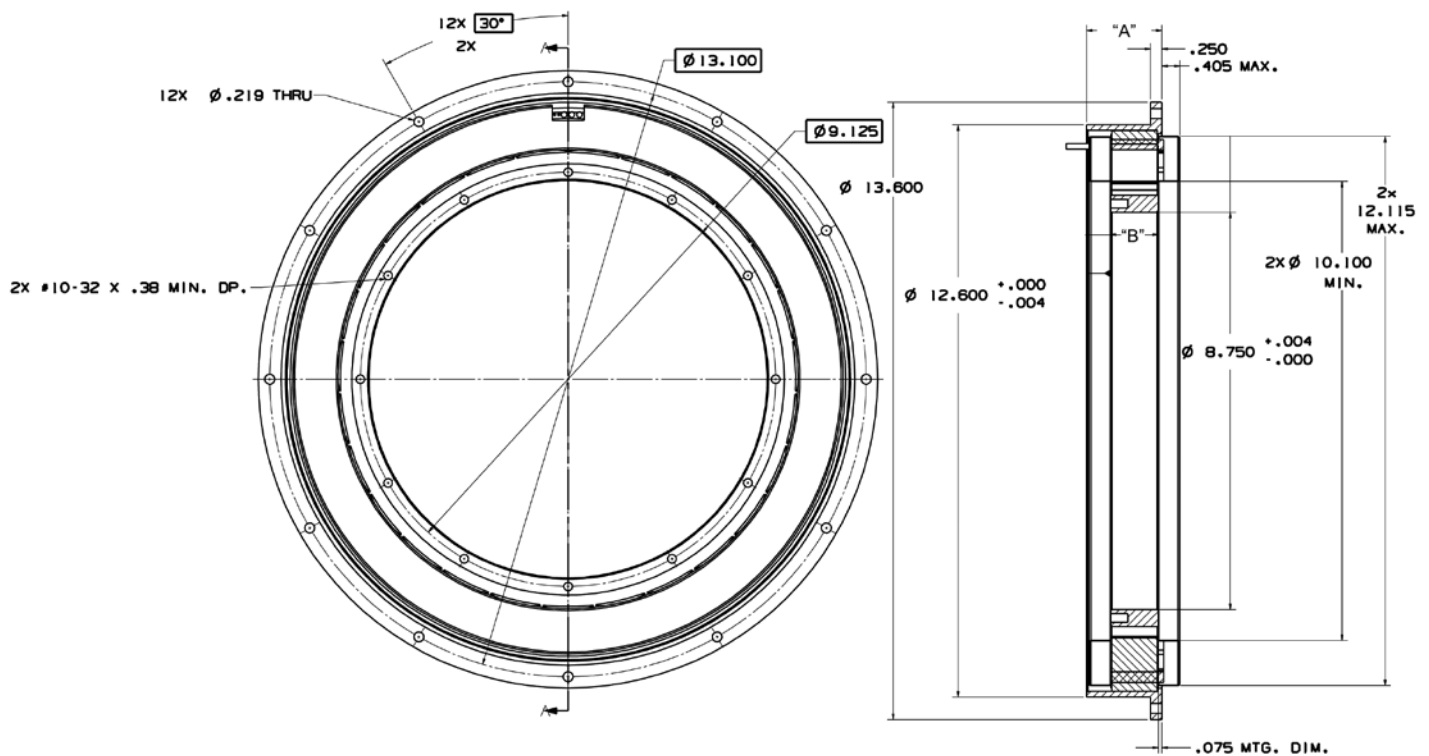

Dimensions are in inches