

BN34 Specifications

BN34 SPECIFICATIONS - Continuous Stall Torque 83 - 309 oz-in (0.587 - 2.19 Nm) Peak Torque 326 - 1445 oz-in (2.31 - 10.21 Nm)

Inside Rotor
Brushless Motors

Part Number*		BN34-25AF- <input type="checkbox"/> <input type="checkbox"/> <input type="checkbox"/> <input type="checkbox"/> <input type="checkbox"/> <input type="checkbox"/>			BN34-35AF- <input type="checkbox"/> <input type="checkbox"/> <input type="checkbox"/> <input type="checkbox"/> <input type="checkbox"/> <input type="checkbox"/>			BN34-45AF- <input type="checkbox"/> <input type="checkbox"/> <input type="checkbox"/> <input type="checkbox"/> <input type="checkbox"/> <input type="checkbox"/>			BN34-55AF- <input type="checkbox"/> <input type="checkbox"/> <input type="checkbox"/> <input type="checkbox"/> <input type="checkbox"/> <input type="checkbox"/>		
Winding Code**		01	02	03	01	02	03	01	02	03	01	02	03
L = Length	inches	2.5			3.5			4.5			5.5		
	millimeters	63.5			88.9			114.3			139.7		
Terminal Voltage	volts DC	24	50	100	24	50	100	24	50	100	24	50	100
Peak Torque	oz-in	310	310	310	657	643	657	1006	1006	1006	1375	1375	1375
	Nm	2.19	2.19	2.19	4.64	4.5405	4.64	7.11	7.11	7.11	9.71	9.71	9.71
Continuous Stall Torque	oz-in	88	93	90	140	162	172	210	220	236	249	288	299
	Nm	0.62	0.66	0.64	0.99	1.144	1.21	1.49	1.55	1.67	1.76	2.03	2.11
Rated Speed	RPM	8130	7500	7280	6010	6400	6380	3800	5170	5270	2750	4350	4360
	rad/sec	851	785	762	629	670	667	397	541	552	288	455	456
Rated Torque	oz-in	60	64	62	93	106	110	172	148	170	214	208	214
	Nm	0.4237	0.45	0.44	0.6567	0.749	0.78	1.24	1.05	1.2005	1.51	1.49	1.51
Rated Current	Amps	16.98	8	3.77	18.74	11	5.8	23.1	12.6	7	21.16	14.85	7.63
Rated Power	watts	361	355	334	417	502	519	483	567	612	435	669	690
Torque Sensitivity	oz-in/amp	3.78	8.5	17.48	5.06	9.92	20.26	7.76	12.42	26.39	10.5	14.7	29.39
	Nm/amp	0.027	0.06	0.123	0.036	0.0701	0.142	0.055	0.088	0.186	0.074	0.104	0.208
Back EMF	volts/KRPM	2.79	6.29	12.92	3.74	7.34	14.98	5.74	9.18	19.51	7.76	10.87	21.73
	volts/rad/sec	0.027	0.06	0.123	0.036	0.07	0.143	0.055	0.088	0.186	0.074	0.104	0.208
Terminal Resistance	ohms	0.079	0.253	1.12	0.05	0.147	0.548	0.068	0.141	0.557	0.088	0.131	0.487
Terminal Inductance	mH	0.12	0.62	2.62	0.1	0.43	1.72	0.17	0.43	1.94	0.23	0.44	1.78
Motor Constant	oz-in/sq.rt.watt	13.44	16.11	16.51	22.63	25.87	27.37	29.75	33.06	35.36	35.4	40.61	42.11
	Nm/sq.rt.watt	0.11	0.11	0.12	0.16	0.183	0.19	0.22	0.23	0.25	0.25	0.29	0.3
Rotor Inertia	oz-in-sec ² x10 ⁻³	7.2	7.2	7.2	14.1	12	14	21	21	21	28	28	28
	g-cm ²	510	510	510	1000	846.8	1000	1500	1500	1500	2000	2000	2000
Weight	oz	36	37	36	62	62	62	87	89	89	114	116	116
	g	1020	1030	1030	1750	1760.8	1770	2480	2520	2530	3230	3300	3.3
# of Poles		8	8	8	8	8	8	8	8	8	8	8	8
Timing		120°	120°	120°	120°	120°	120°	120°	120°	120°	120°	120°	120°
Mech. Time Constant	ms	3.87	3.58	3.75	3.96	2.5	2.7	3.38	2.75	2.41	3.2	2.43	2.26
Electrical Time Constant	ms	2.27	2.45	2.34	2.14	2.9	3.15	2.48	3.04	3.48	2.58	3.4	3.66
Thermal Resistivity	deg. C/watt	2.25	2.39	2.41	1.87	1.84	1.84	1.51	1.63	1.62	1.45	1.43	1.43
Speed/Torque Gradient	rpm/oz-in	5.3	4.3	4.3	2.8	2.8	1.8	1.1	1	1	0.8	0.7	0.6

Notes:

- Motor mounted to a 10 x 10 x 1/4 inches aluminum plate, still air.
- Maximum winding temperature of 155°C.
- Typical electrical specifications at 25°C.
- Motor Terminal Voltages are representative only; motors may be operated at voltages other than those listed in the table. For assistance please contact our applications engineer.
- For MS (military style) connector, please specify connector housing and terminal.
- Data for informational purposes only. Should not be considered a binding performance agreement. For specific applications, please contact the factory.

*Many other custom mechanical options are available – consult factory.

**Many other winding options are available – consult factory.

Select your options below and place their code in its corresponding block as shown on page 5.

- | | | |
|--|---|--|
| <input checked="" type="checkbox"/> TERMINATION | <input checked="" type="checkbox"/> FEEDBACK OPTIONS | <input checked="" type="checkbox"/> OTHER OPTIONS |
| L – Leads (std) | H – Hall Effect (std) | E – Encoder |
| C – Connector | R – Resolver | G – Gearhead |
| M – MS connector | S – Sensorless | |

BN34 Housed / Frameless

Inside Rotor
Brushless Motors

BN34 Typical Outline - Housed

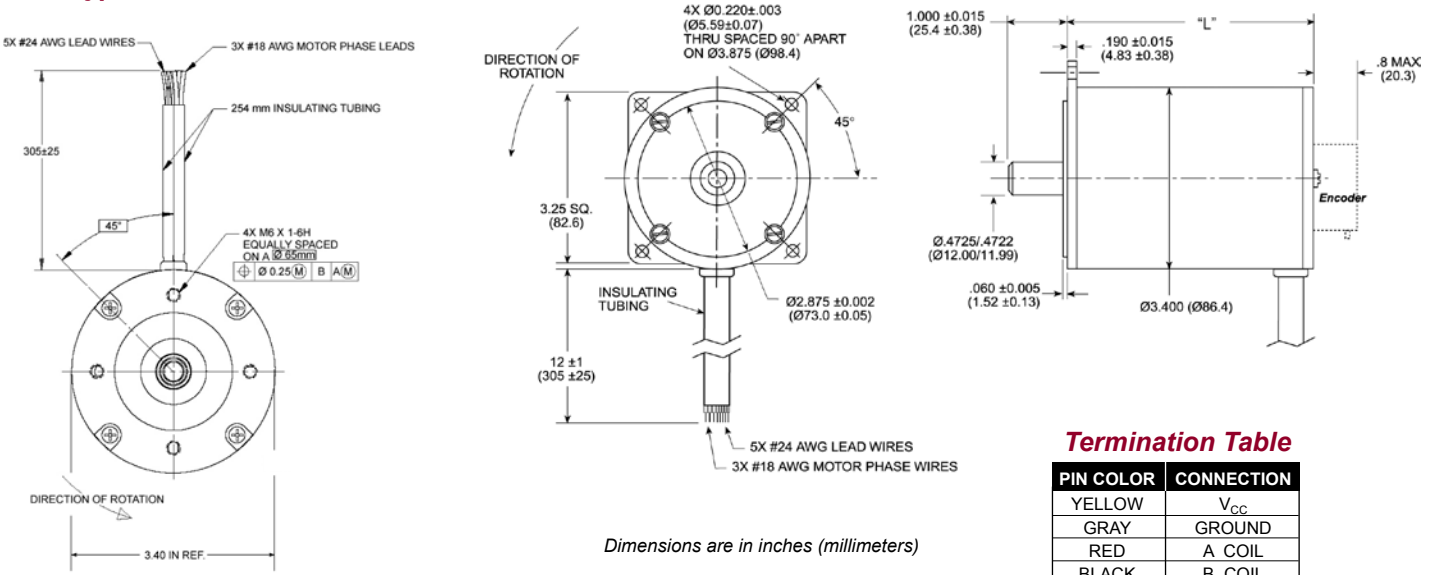

Termination Table

PIN COLOR	CONNECTION
YELLOW	V _{CC}
GRAY	GROUND
RED	A COIL
BLACK	B COIL
GREEN	C COIL
BLUE	S2 OUT
BROWN	S1 OUT
ORANGE	S3 OUT

BN34 Typical Outline - Frameless

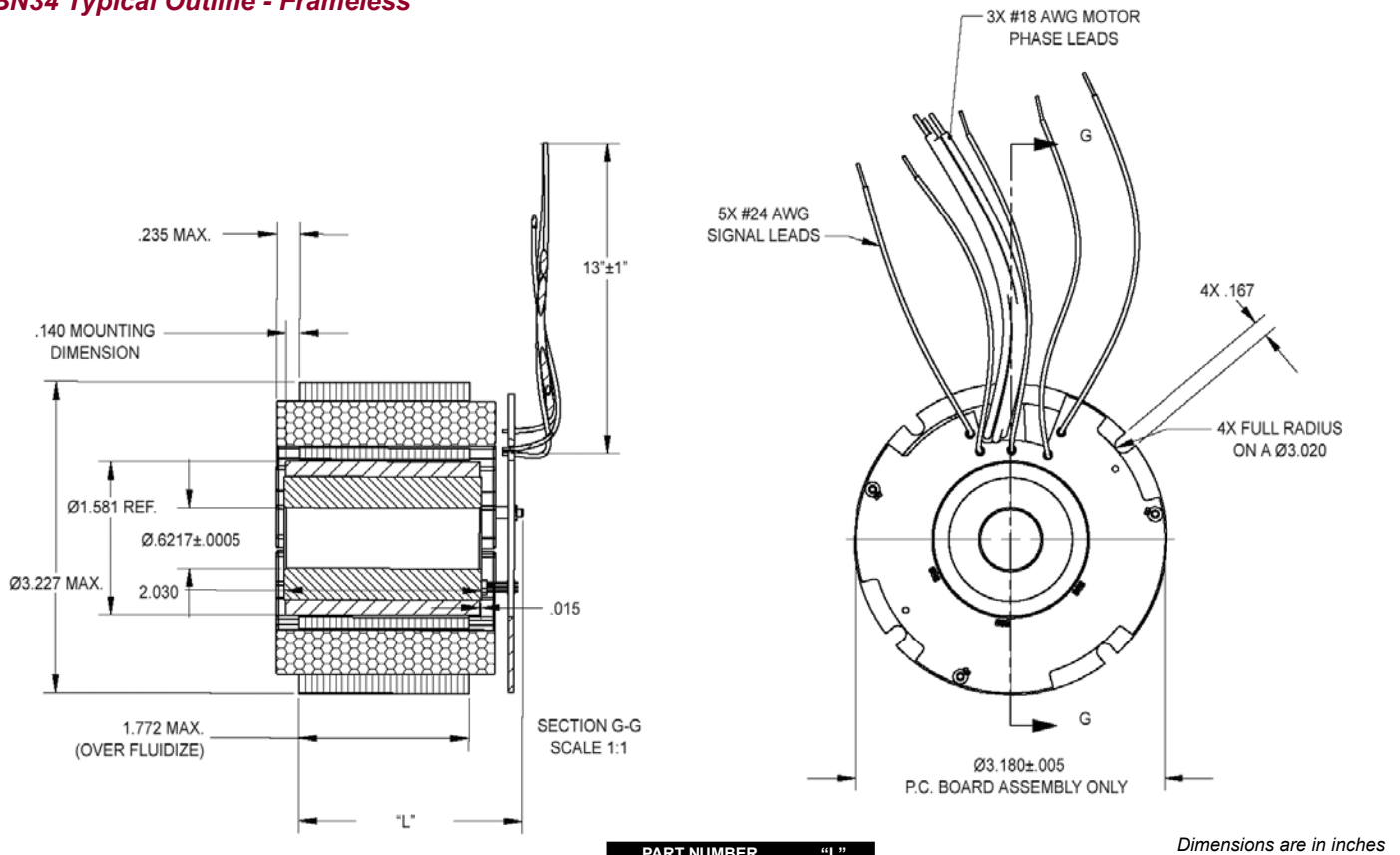

PART NUMBER	"L"
BN34-25ZP-[] [-LH]	1.337
BN34-35ZP-[] [-LH]	2.337
BN34-45ZP-[] [-LH]	3.337
BN34-55ZP-[] [-LH]	4.337

Note: See page 29 for performance data.

BN34 Performance Curves

BN34 Performance Curves

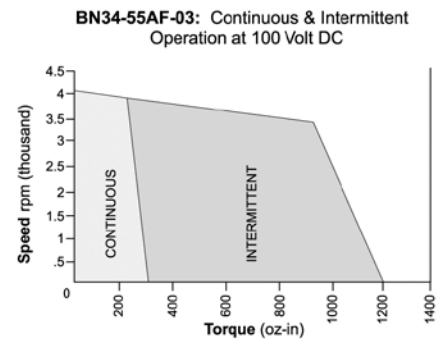
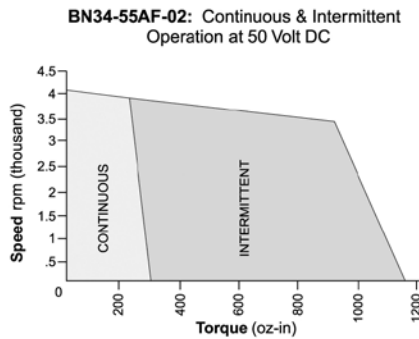
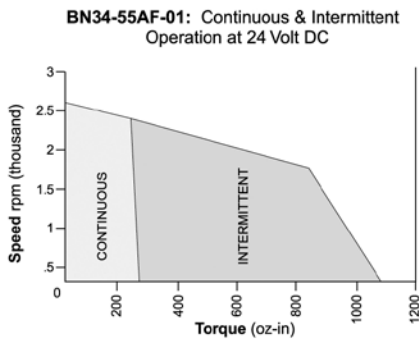
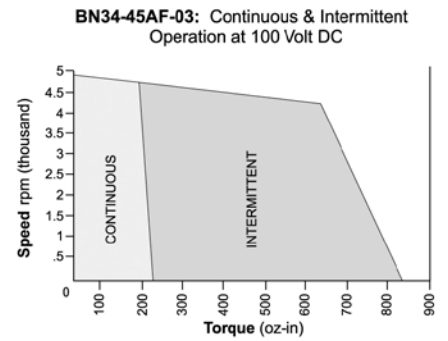
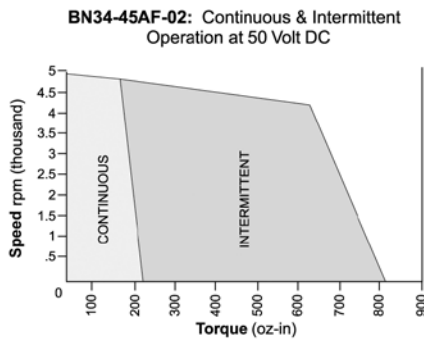
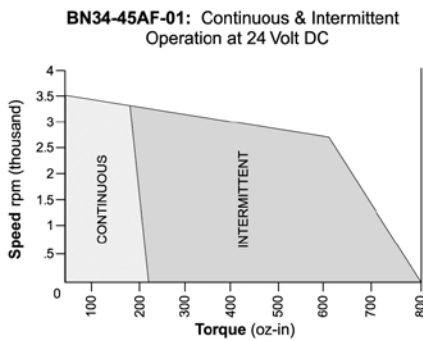
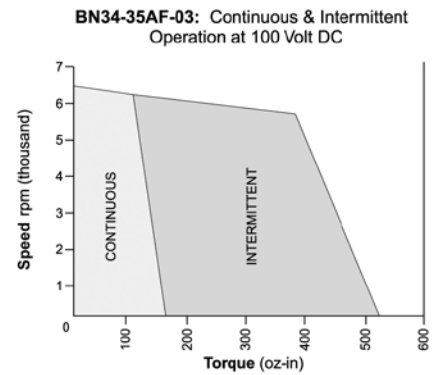
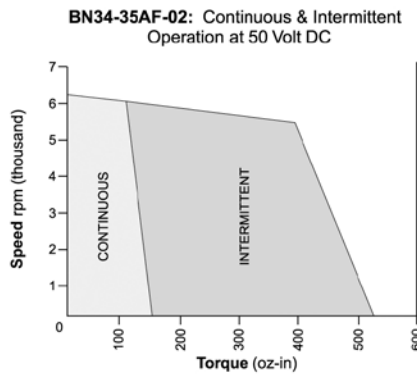
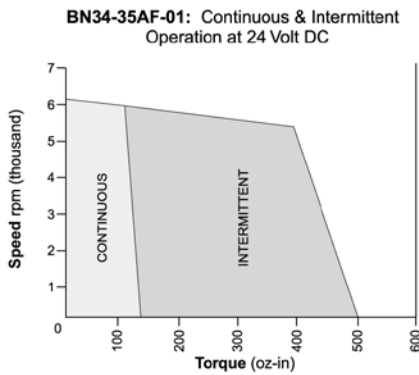
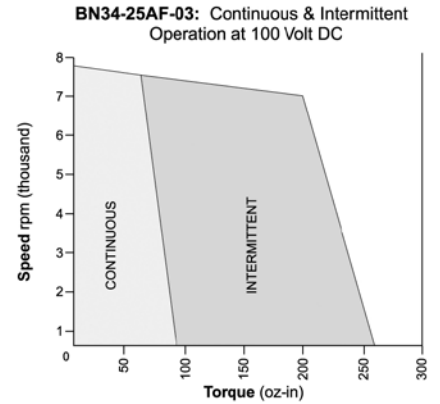
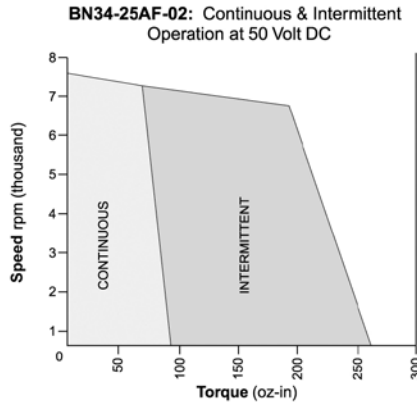
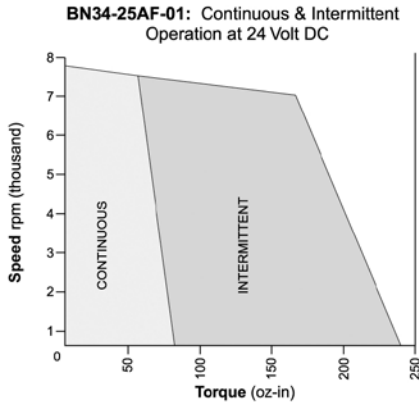

Note: Intermittent operation is based on a 20% duty cycle of one minute on, four minutes off.
Please contact the factory regarding the duty cycle of your application.

BN34 EU Specifications

Inside Rotor
Brushless Motors

BN34 EU SPECIFICATIONS -

Continuous Stall Torque 83 - 309 oz-in (0.587 - 2.19 Nm)
Peak Torque 326 - 1445 oz-in (2.31 - 10.21 Nm)

Part Number*		BN34-25EU- <input type="checkbox"/> <input type="checkbox"/> <input type="checkbox"/> <input type="checkbox"/>			BN34-35EU- <input type="checkbox"/> <input type="checkbox"/> <input type="checkbox"/> <input type="checkbox"/>			BN34-45EU- <input type="checkbox"/> <input type="checkbox"/> <input type="checkbox"/> <input type="checkbox"/>			BN34-55EU- <input type="checkbox"/> <input type="checkbox"/> <input type="checkbox"/> <input type="checkbox"/>		
Winding Code**		01	02	03	01	02	03	01	02	03	01	02	03
L = Length	inches	2.5			3.5			4.5			5.5		
	millimeters	63.5			88.9			114.3			139.7		
Terminal Voltage	volts DC	24	50	100	24	50	100	24	50	100	24	50	100
Peak Torque	oz-in	310	310	310	657	643	657	1006	1006	1006	1375	1375	1375
	Nm	2.19	2.19	2.19	4.64	4.5405	4.64	7.11	7.11	7.11	9.71	9.71	9.71
Continuous Stall Torque	oz-in	88	93	90	140	162	172	210	220	236	249	288	299
	Nm	0.62	0.66	0.64	0.99	1.144	1.21	1.49	1.55	1.67	1.76	2.03	2.11
Rated Speed	RPM	8130	7500	7280	6010	6400	6380	3800	5170	5270	2750	4350	4360
	rad/sec	851	785	762	629	670	667	397	541	552	288	455	456
Rated Torque	oz-in	60	64	62	93	106	110	172	148	170	214	208	214
	Nm	0.4237	0.45	0.44	0.6567	0.749	0.78	1.24	1.05	1.2005	1.51	1.49	1.51
Rated Current	Amps	16.98	8	3.77	18.74	11	5.8	23.1	12.6	7	21.16	14.85	7.63
Rated Power	watts	361	355	334	417	502	519	483	567	612	435	669	690
Torque Sensitivity	oz-in/amp	3.78	8.5	17.48	5.06	9.92	20.26	7.76	12.42	26.39	10.5	14.7	29.39
	Nm/amp	0.027	0.06	0.123	0.036	0.0701	0.142	0.055	0.088	0.186	0.074	0.104	0.208
Back EMF	volts/KRPM	2.79	6.29	12.92	3.74	7.34	14.98	5.74	9.18	19.51	7.76	10.87	21.73
	volts/rad/sec	0.027	0.06	0.123	0.036	0.07	0.143	0.055	0.088	0.186	0.074	0.104	0.208
Terminal Resistance	ohms	0.079	0.253	1.12	0.05	0.147	0.548	0.068	0.141	0.557	0.088	0.131	0.487
Terminal Inductance	mH	0.12	0.62	2.62	0.1	0.43	1.72	0.17	0.43	1.94	0.23	0.44	1.78
Motor Constant	oz-in/sq.rt.watt	13.44	16.11	16.51	22.63	25.87	27.37	29.75	33.06	35.36	35.4	40.61	42.11
	Nm/sq.rt.watt	0.11	0.11	0.12	0.16	0.183	0.19	0.22	0.23	0.25	0.25	0.29	0.3
Rotor Inertia	oz-in-sec ²	7.2	7.2	7.2	14.1	12	14	21	21	21	28	28	28
	g-cm ²	510	510	510	1000	846.8	1000	1500	1500	1500	2000	2000	2000
Weight	oz	36	37	36	62	62	62	87	89	89	114	116	116
	g	1020	1030	1030	1750	1760.8	1770	2480	2520	2530	3230	3300	3.3

Notes:

- Motor mounted to a 10 x 10 x 1/4 inches aluminum plate, still air.
- Maximum winding temperature of 155°C.
- Typical electrical specifications at 25°C.
- Motor Terminal Voltages are representative only; motors may be operated at voltages other than those listed in the table. For assistance please contact our applications engineer.
- For MS (military style) connector, please specify connector housing and terminal.
- Data for informational purposes only. Should not be considered a binding performance agreement. For specific applications, please contact the factory.

*Many other custom mechanical options are available – consult factory.

**Many other winding options are available – consult factory.

Select your options below and place their code in its corresponding block as shown on page 5.

- | | | |
|---|--|---|
| <input type="checkbox"/> TERMINATION | <input type="checkbox"/> FEEDBACK OPTIONS | <input type="checkbox"/> OTHER OPTIONS |
| L – Leads (std) | H – Hall Effect (std) | E – Encoder |
| C – Connector | R – Resolver | G – Gearhead |
| M – MS connector | S – Sensorless | |

BN34 EU Typical Outline

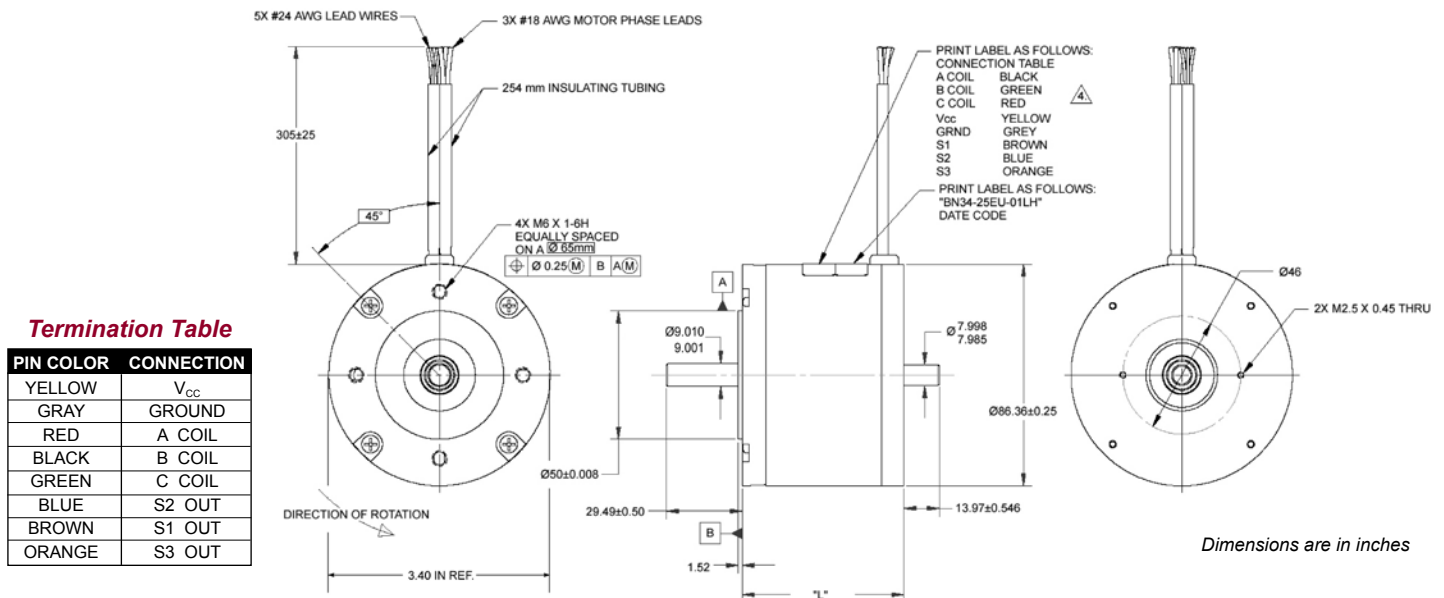

BN34 IP65 Specifications

Inside Rotor
Brushless Motors

BN34 IP65 SPECIFICATIONS - Continuous Stall Torque 83 - 309 oz-in (0.587 - 2.19 Nm) Peak Torque 326 - 1445 oz-in (2.31 - 10.21 Nm)

Part Number*		BN34-25IP - <input type="checkbox"/> <input type="checkbox"/> <input type="checkbox"/> <input type="checkbox"/> <input type="checkbox"/>			BN34-35IP - <input type="checkbox"/> <input type="checkbox"/> <input type="checkbox"/> <input type="checkbox"/> <input type="checkbox"/>			BN34-45IP - <input type="checkbox"/> <input type="checkbox"/> <input type="checkbox"/> <input type="checkbox"/> <input type="checkbox"/>			BN34-55IP - <input type="checkbox"/> <input type="checkbox"/> <input type="checkbox"/> <input type="checkbox"/> <input type="checkbox"/>		
Winding Code**		01	02	03	01	02	03	01	02	03	01	02	03
L = Length	inches	2.5			3.5			4.5			5.5		
	millimeters	63.5			88.9			114.3			139.7		
Terminal Voltage	volts DC	24	50	100	24	50	100	24	50	100	24	50	100
Peak Torque	oz-in	310	310	310	657	643	657	1006	1006	1006	1375	1375	1375
	Nm	2.19	2.19	2.19	4.64	4.5405	4.64	7.11	7.11	7.11	9.71	9.71	9.71
Continuous Stall Torque	oz-in	88	93	90	140	162	172	210	220	236	249	288	299
	Nm	0.62	0.66	0.64	0.99	1.144	1.21	1.49	1.55	1.67	1.76	2.03	2.11
Rated Speed	RPM	8130	7500	7280	6010	6400	6380	3800	5170	5270	2750	4350	4360
	rad/sec	851	785	762	629	670	667	397	541	552	288	455	456
Rated Torque	oz-in	60	64	62	93	106	110	172	148	170	214	208	214
	Nm	0.4237	0.45	0.44	0.6567	0.749	0.78	1.24	1.05	1.2005	1.51	1.49	1.51
Rated Current	Amps	16.98	8	3.77	18.74	11	5.8	23.1	12.6	7	21.16	14.85	7.63
Rated Power	watts	361	355	334	417	502	519	483	567	612	435	669	690
Torque Sensitivity	oz-in/amp	3.78	8.5	17.48	5.06	9.92	20.26	7.76	12.42	26.39	10.5	14.7	29.39
	Nm/amp	0.027	0.06	0.123	0.036	0.0701	0.142	0.055	0.088	0.186	0.074	0.104	0.208
Back EMF	volts/KRPM	2.79	6.29	12.92	3.74	7.34	14.98	5.74	9.18	19.51	7.76	10.87	21.73
	volts/rad/sec	0.027	0.06	0.123	0.036	0.07	0.143	0.055	0.088	0.186	0.074	0.104	0.208
Terminal Resistance	ohms	0.079	0.253	1.12	0.05	0.147	0.548	0.068	0.141	0.557	0.088	0.131	0.487
Terminal Inductance	mH	0.12	0.62	2.62	0.1	0.43	1.72	0.17	0.43	1.94	0.23	0.44	1.78
Motor Constant	oz-in/sq.rt.watt	13.44	16.11	16.51	22.63	25.87	27.37	29.75	33.06	35.36	35.4	40.61	42.11
	Nm/sq.rt.watt	0.11	0.11	0.12	0.16	0.183	0.19	0.22	0.23	0.25	0.25	0.29	0.3
Rotor Inertia	oz-in-sec ² x10 ⁻³	7.2	7.2	7.2	14.1	12	14	21	21	21	28	28	28
	g-cm ²	510	510	510	1000	846.8	1000	1500	1500	1500	2000	2000	2000
Weight	oz	36	37	36	62	62	62	87	89	89	114	116	116
	g	1020	1030	1030	1750	1760.8	1770	2480	2520	2530	3230	3300	3.3
# of Poles		8	8	8	8	8	8	8	8	8	8	8	8
Timing		120°	120°	120°	120°	120°	120°	120°	120°	120°	120°	120°	120°
Mech. Time Constant	ms	3.87	3.58	3.75	3.96	2.5	2.7	3.38	2.75	2.41	3.2	2.43	2.26
Electrical Time Constant	ms	2.27	2.45	2.34	2.14	2.9	3.15	2.48	3.04	3.48	2.58	3.4	3.66
Thermal Resistivity	deg. C/watt	2.25	2.39	2.41	1.87	1.84	1.84	1.51	1.63	1.62	1.45	1.43	1.43
Speed/Torque Gradient	rpm/oz-in	5.3	4.3	4.3	2.8	2.8	1.8	1.1	1	1	0.8	0.7	0.6

Notes:

- Motor mounted to a 10 x 10 x 1/4 inches aluminum plate, still air.
- Maximum winding temperature of 155°C.
- Typical electrical specifications at 25°C.
- Motor Terminal Voltages are representative only; motors may be operated at voltages other than those listed in the table. For assistance please contact our applications engineer.
- Calculated (theoretical) speed/torque gradient.
- For MS (military style) connector, please specify connector housing and terminal.
- Data for informational purposes only. Should not be considered a binding performance agreement. For specific applications, please contact the factory.

*Many other custom mechanical options are available – consult factory.
**Many other winding options are available – consult factory.

Select your options below and place their code in its corresponding block as shown on page 5.

- | | | |
|--|---|--|
| <input checked="" type="checkbox"/> TERMINATION | <input checked="" type="checkbox"/> FEEDBACK OPTIONS | <input checked="" type="checkbox"/> OTHER OPTIONS |
| L – Leads (std) | H – Hall Effect (std) | E – Encoder |
| C – Connector | R – Resolver | G – Gearhead |
| M – MS connector | S – Sensorless | |

BN34 IP65 Typical Outline

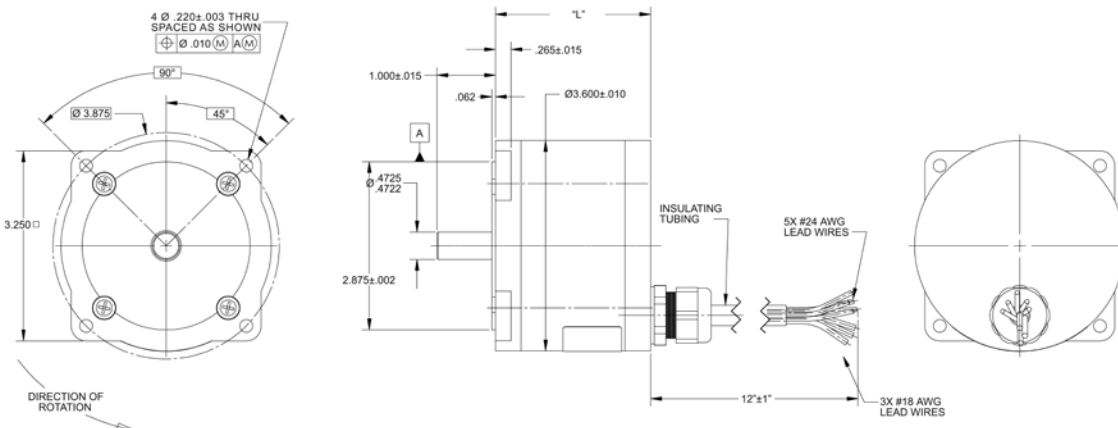

Termination Table

PIN COLOR	CONNECTION
YELLOW	V _{CC}
GRAY	GROUND
RED	A COIL
BLACK	B COIL
GREEN	C COIL
BLUE	S2 OUT
BROWN	S1 OUT
ORANGE	S3 OUT

Dimensions are in inches

BN34 IP65 Performance Curves

BN34 IP65 Performance Curves

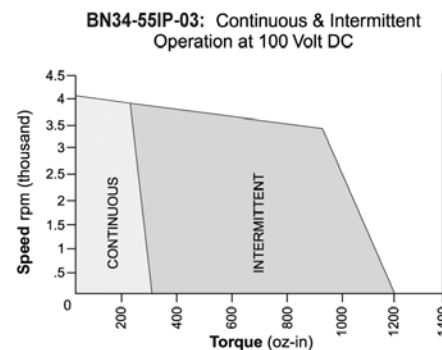
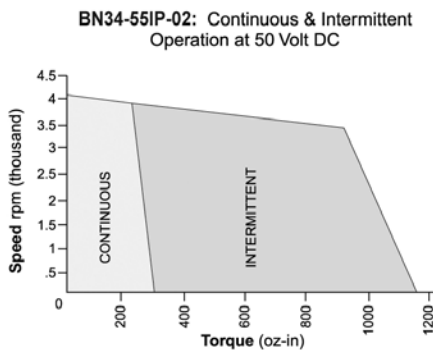
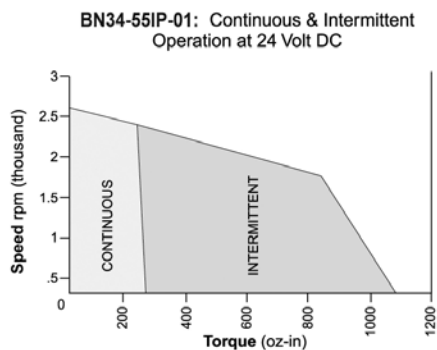
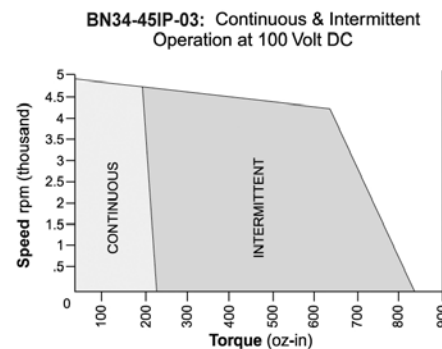
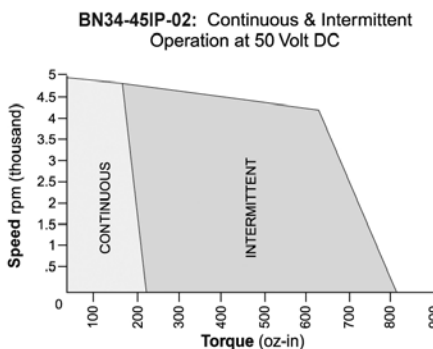
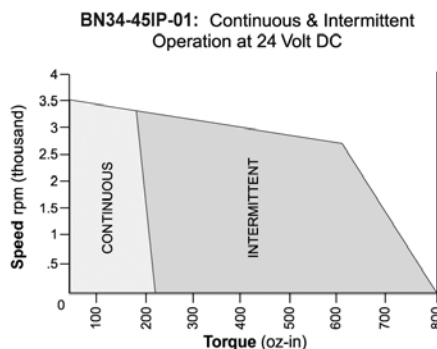
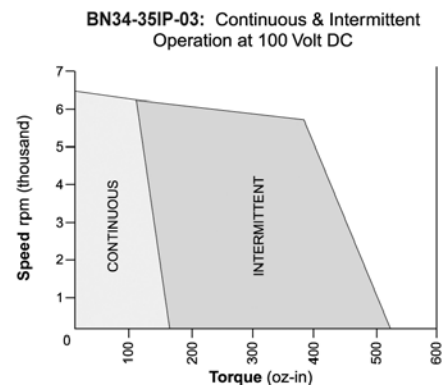
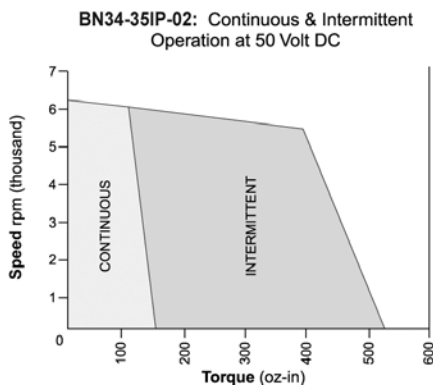
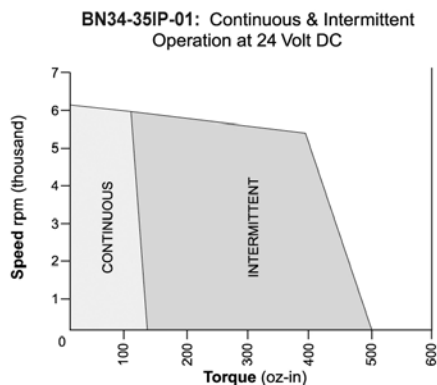
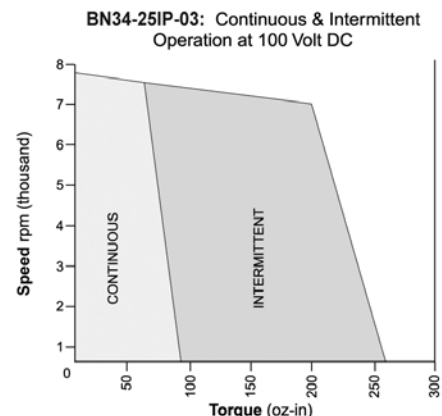
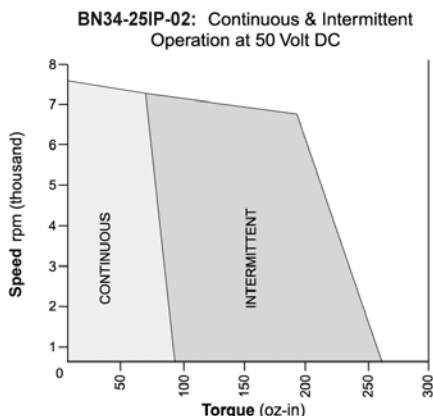
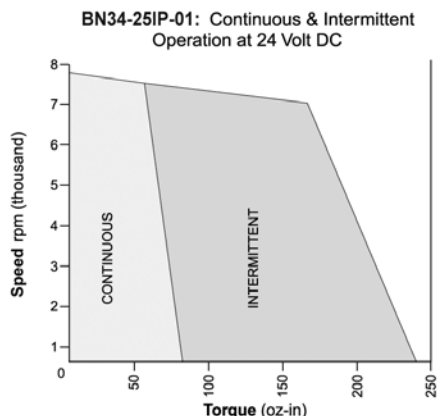

Note: Intermittent operation is based on a 20% duty cycle of one minute on, four minutes off. Please contact the factory regarding the duty cycle of your application.