

D-1500-Z-1 Specifications

D-1500-Z-1 SPECIFICATIONS @ 25°C

Size Constants	Value	Units
Peak Torque, T_P	18	oz-in
Motor Constant, K_M	3.02	oz-in/ \sqrt{W}
Number of Poles	6	
Weight	6.4	oz (nom)
Motor Inertia, J_M	1.40E-03	oz-in-s ²
Friction Torque, T_F	0.95	oz-in
Electrical Time Constant, τ_E	0.451	ms
Mechanical Time Constant, τ_M	21.72	ms
Temperature Rise, Housed TPR'	12	° C/W
Ripple Torque, T_R	10	max. avg. to peak (%)
Winding Constants	Value	Units
Torque Sensitivity, K_T	14	oz-in/amp
Back EMF, K_E	0.099	V per rad/s
Terminal Resistance, R_M	21.5	ohms (nom)
Terminal Inductance, L_M	9.7	mH (nom)
Voltage, Stalled at Peak Torque, V_P	28	volts
Amps at Peak Torque, I_P	1.30	amps

Brush Motors

D-1500-Z-1 Typical Outline Drawing

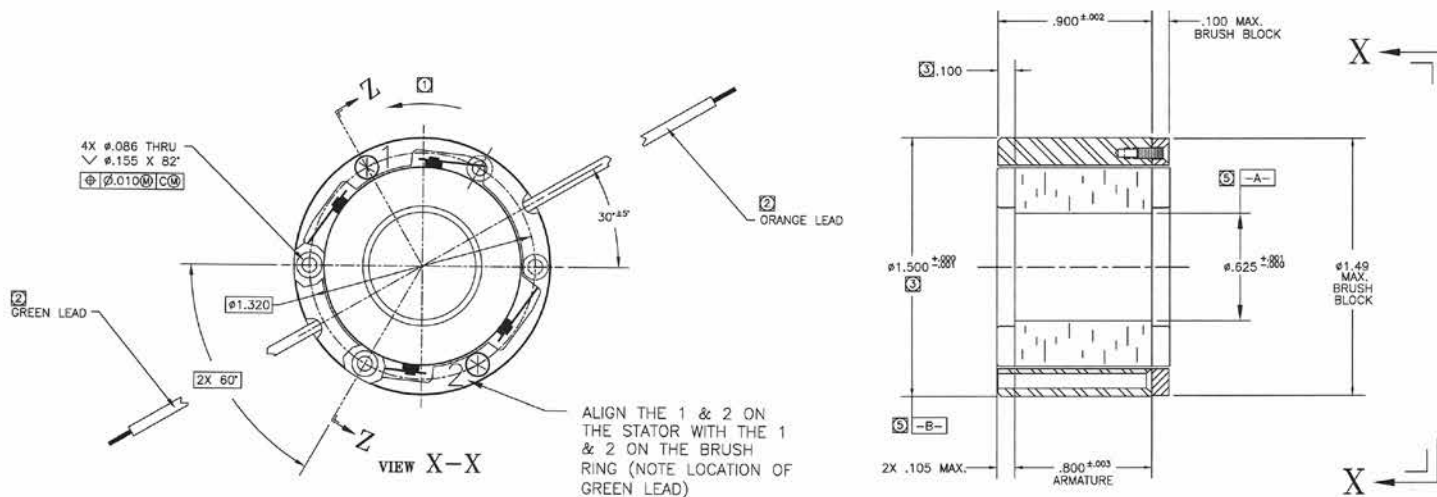

Dimensions are in inches