

High Speed Slip Ring Capsules

PH Series

Description

Suitable for industrial applications such as general purpose instrumentation and testing, the PH series rugged design makes it an optimum choice for adverse operating conditions. Continuous silver connection ensuring minimal thermal error making this design compatible with thermocouple and strain gauge instrumentation.

Quick and easy to install, these units are available with either 8 or 12 circuits. Both options operate at speeds up to 20,000 rotations per minute.

Features

- Optimum for adverse operating conditions
- Continuous silver connection ensuring minimal thermal error
- Compatible with the thermocouple and strain gauge instrumentation
- Quick and easy to install
- Available with either 8 or 12 circuits
- Speeds up to 20,000 rotations per minute

Benefits

- Compact size
- Low drive torque requirement



Typical Applications

- Test apparatus for thermocouples and strain gages
- General purpose instrumentation and testing

High Speed Slip Ring Capsules

PH Series Specifications

Terminals	Silver
Mounting	Flange mounting - 4 holes M2
Maximum Voltage	50 volts
Temperature Range	-20°C to +90°C
Maximum Current	2 amps
Cooling Air Pressure	1.4kg / cm ²

*Please note that the operational life of the unit is dependent upon rotational speed, environment and temperature.

Note: Operation at maximum rotational speed requires cooling air to be supplied through the inlet and outlet ports provided.

Series	Part Number	Number of Circuits	Length (A)	Max. Speed RPM
PH 08	80042-950	8	57,15 mm	20.000
PH 12	80043-950	12	69,85 mm	20.000

PH Series Dimensions

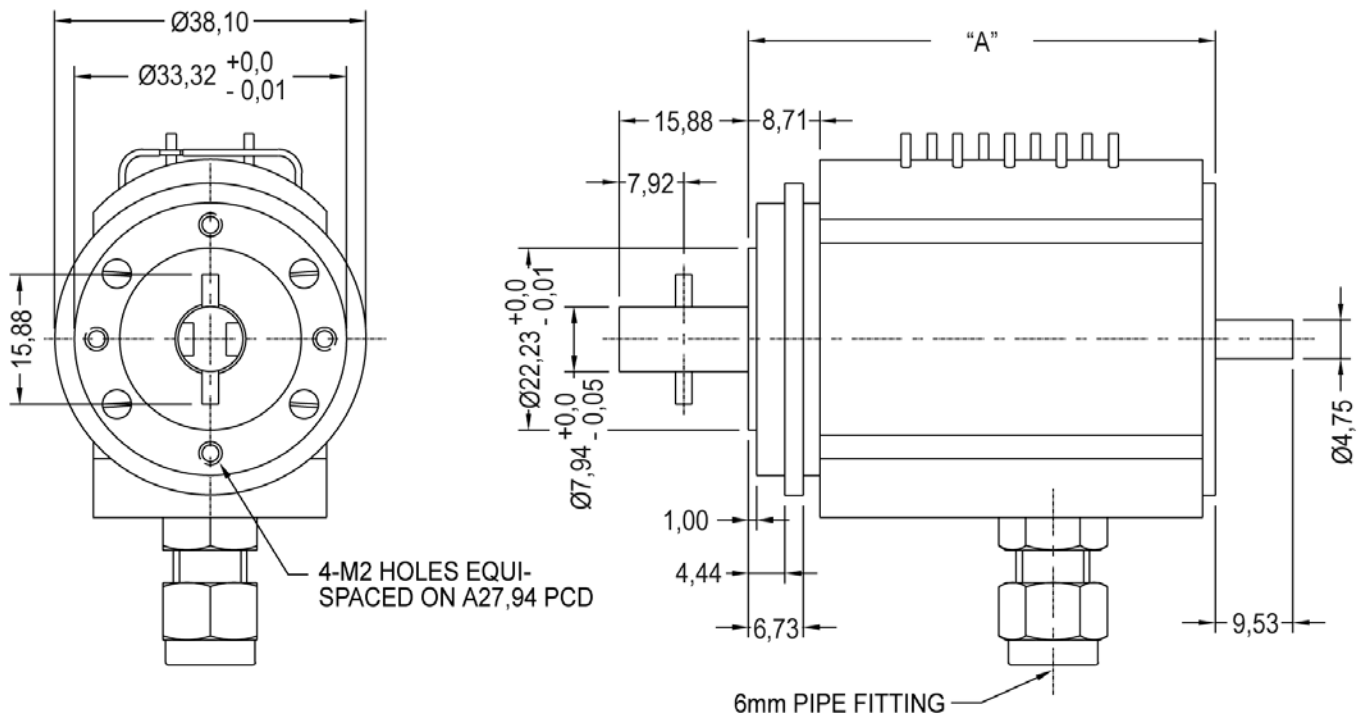

Dimensions in millimeters