

# High Speed Slip Ring Capsules

## PM Series

### Description

Suitable for a wide variety of industrial applications, the PM series is designed to transmit power and data signals at high speeds. Compatible with thermocouple and strain gauge instrumentation, the PM series is designed to maintain reliable performance under adverse operating conditions. Continuous silver connections ensure minimal thermal error. Quick and easy to install and available with 8, 12 and 24 circuits.

### Features

- Suitable for a wide variety of industrial applications
- Transmits power and data signals at high speeds
- Compatible with thermocouple and strain gauge instrumentation
- Reliable performance under adverse operating conditions
- Continuous silver connections ensure minimal thermal error
- Quick and easy to install
- Available with 8, 12 and 24 circuits

### Benefits

- High rotational speed
- Low torque required to drive this unit

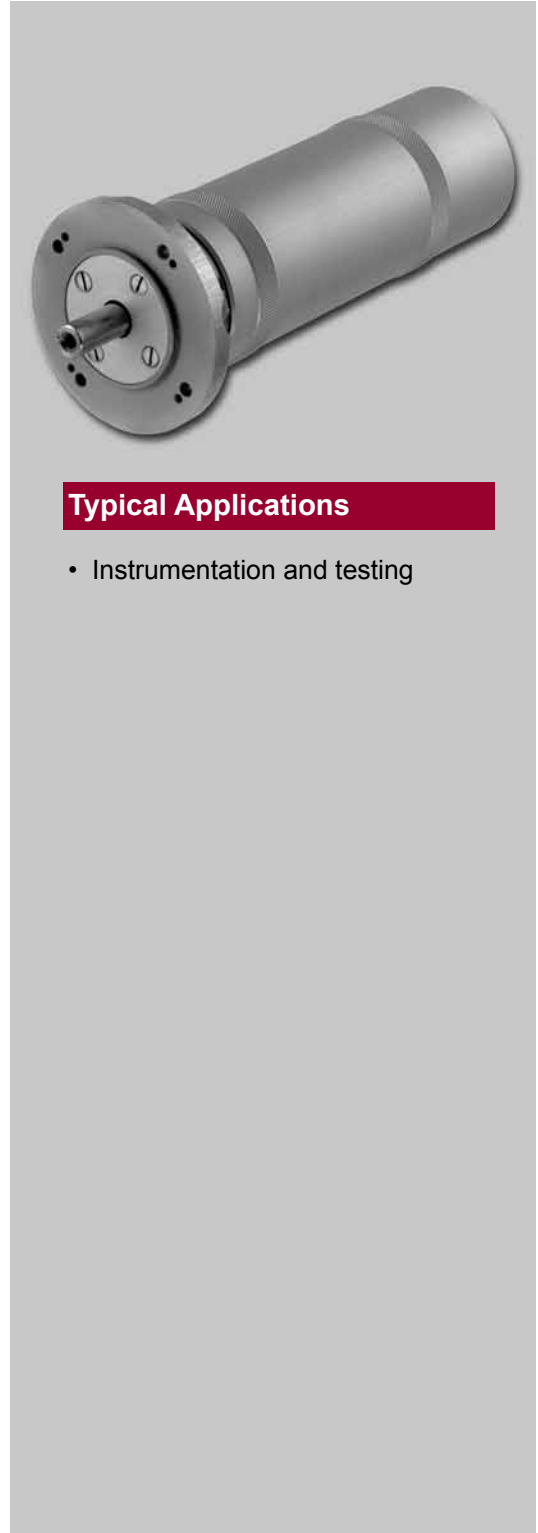

### Typical Applications

- Instrumentation and testing

# High Speed Slip Ring Capsules

PM Series Specifications	
Terminals	Silver
Mounting	Flange mounted 4 holes $\varnothing 5,1$ mm equi-spaced on a 73,0 mm P.C.D.
Cooling Air Pressure	1.4kg / cm <sup>2</sup>
Brush Lifting Air Pressure	4.2 kg / cm <sup>2</sup>
Maximum Voltage	50 volts
Temperature Range	-20°C to +90°C
Maximum Current	2.5 amps

*\*Please note that the operational life of the unit is dependent upon rotational speed, environment and temperature.*

**Note:** Operation at maximum rotational speed requires cooling air to be supplied through the inlet and outlet ports provided.

Series	Part Number	Number of Ways	Length Diameter	Weight gm	Starting Torque g-cm	Maximum Speed RPM
PM-08	80038-950	8	132 mm	1000	290	12,000
PM-12	80039-950	12	147 mm	1140	406	12,000
PM-24	80027-950	24	216 mm	1820	812	12,000

## PM Series Dimensions

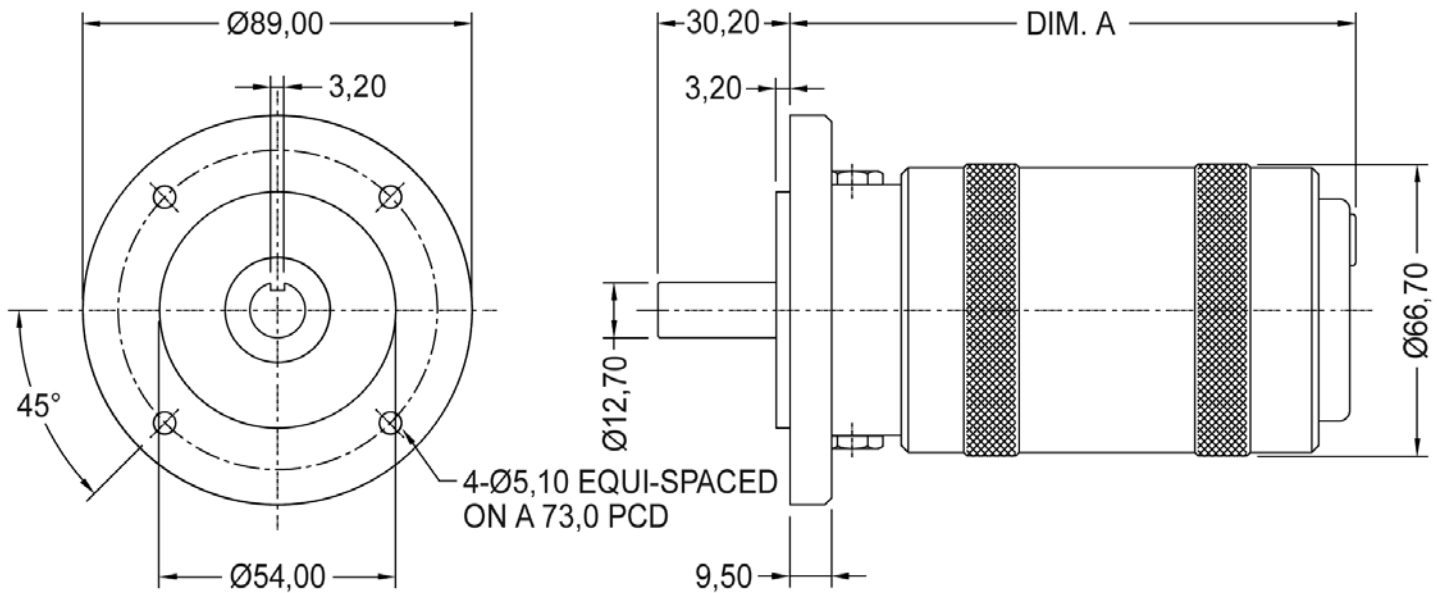

*Dimensions in millimeters*