

SRA-73830-[]-JXX

Integrated slip ring and fiber optic rotary joint

Description

A slip ring and Fiber Optic Rotary Joint (FORJ) can be used in any electromechanical system that requires unrestrained, continuous rotation while transferring power and data from a stationary to a rotating structure.

The SRA-73830-[]-JXX series provides a wide range of electrical connections, both power and signal, coupled with a singlemode or multimode FORJ to address today's increasing demand for reliable data transfer through a rotary interface. This design is well suited to applications where size is at a premium and reliability is a must.

The assembly provides a flange for convenient mounting of the stationary housing and drive pins to turn the rotating portion. Housing is plastic (standard) with aluminum and stainless steel options when required for a more demanding application.

Slip Ring Features

- Wide range of electrical options including:
 - Signal circuits handle up to 2 amps. Consult factory to discuss application
 - 100BaseT and 1000BaseT Ethernet
- Multiple circuit configurations
- Compact
- Plug-and-play Ethernet
- Integrates capability of SRA-73683, SRA-73801 and SRA-73808 under one part number, plus 8 amp power capability
- Can be integrated with a fiber optic rotary joint

FORJ Features

- Provides rotary coupling for a multimode fiber link
- Passive bidirectional device
- Low cost, small size
- Can be combined with our electrical slips and fluid unions
- Alternative drive coupling and mounting arrangements are available (consult factory for specification details)
- Can be integrated into existing slip ring designs
- Stainless steel or aluminum construction
- Rugged design
 - MIL-STD-167-1 ship vibration
 - MIL-STD-810F functional shock (40 g)
- 90° fiber exits available for limited space requirements



Typical Applications

- Unmanned vehicles
- Robots
- Surveillance systems
- Automated machinery

Fiber Optic Hybrid Units

SRA-73830-[J]-JXX Dimensions

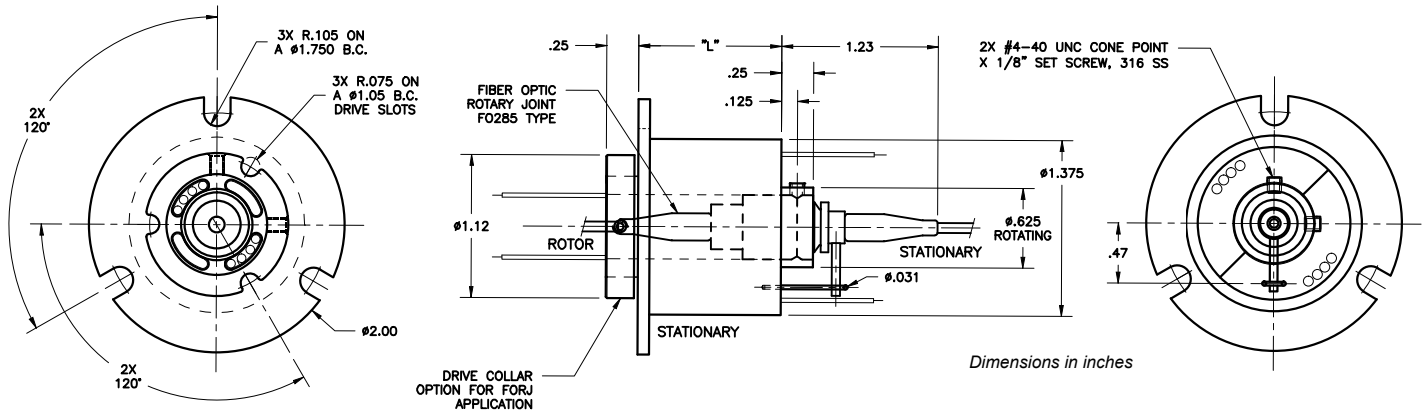

Part Number	"L"
SRA-73830-12	1.12 inch (28.4 mm)
SRA-73830-18	1.42 inch (36.1 mm)
SRA-73830-24	1.72 inch (43.7 mm)

For required electrical and fiber optic rotary joint features, please define the slip ring from data sheet SRA-73830 and FORJ from the table below. For additional details on the FORJ, please refer to FO285 / 286 data sheet. A final configuration part number will be assigned by factory at time of order.

SRA-73830-[J]-JXX Part Numbering Scheme and FORJ Options

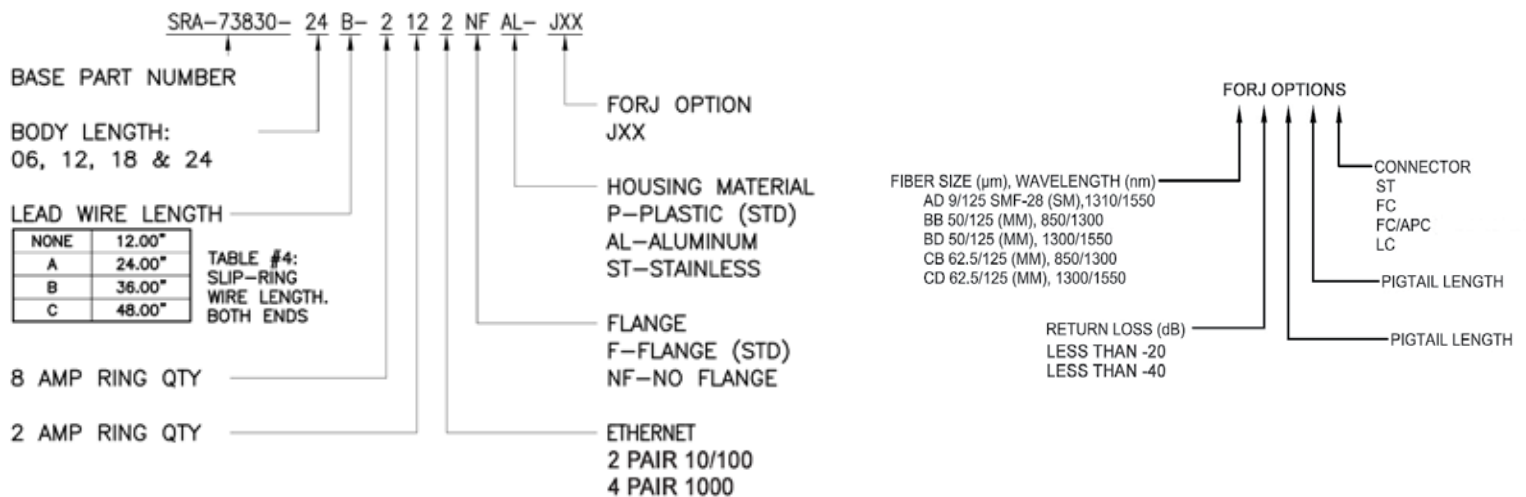

Specifications and information are subject to change without prior notice.
© 2016 Moog Inc. MS3268 09/16

Americas
Moog Components Group
1213 North Main Street
Blacksburg, VA 24060
United States

Tel: +1 540-552-3011
Fax: +1 540-557-6400

Asia-Pacific
Moog Components Group
Yokohama Nishiguchi KN Bldg. 10F
2-8-4 Kitasaiwai, Nishi-ku
Yokohama, Kanagawa 220-0004
Japan

Tel: +81 45-328-1803
Fax: +81 45-328-1801

Europe
Moog Components Group
30 Suttons Business Park
Reading, Berkshire RG6 1AW
United Kingdom

Tel: +44 (0) 118-966-6044
Fax: +44 (0) 118-966-6524

MOOG
COMPONENTS GROUP

www.moog.com/components

Email: mcg@moog.com