

Mercury Series

Fast Ethernet, External D38999, 100Base-TX/FX Media Converter, 28VDC, Multimode, 1310nm

Single Port, Flange Receptacles

FEATURES

- Compliant with IEEE-802.3u Fast Ethernet
- Optical fiber link distances up to 2.0 Kilometers
- Maximum optical channel bit error rate less than 2.5×10^{-10}
- Operating temperature range from -40°C to $+85^{\circ}\text{C}$
- Shock, vibration and immersion resistant per MIL-STD-810
- Olive Drab Cadmium plating meets stringent EMI / RFI performance specifications
- Aluminum alloy chassis and MIL-DTL-38999 housings are strong, durable, corrosion resistant and light weight
- MIL-T-29504 compliant optical fiber connector interface
- D38999 fiber optic insert configuration conforms to MIL-STD-1560
- D38999 electrical interfaces provides robust interconnection to vehicle wiring

APPLICATIONS

Mercury series bulkhead mounted Fast Ethernet media converters enable high speed network communications over long distances in harsh environments.

- Fast Ethernet switches and peripherals
- Telecom and datacom switch / router rack-to-rack links
- Storage or computation clusters

The MIL-DTL-38999, Series III connectors provide sealed optical and electrical interfaces that are water-tight to Mil-Std-810 / IP67 / NEMA-4x when mated.

The multimode optical fiber interface supports applications where copper cable link distance, bandwidth, weight or bulk make the use of twisted pair, twinax or quadrx copper conductors unacceptable.

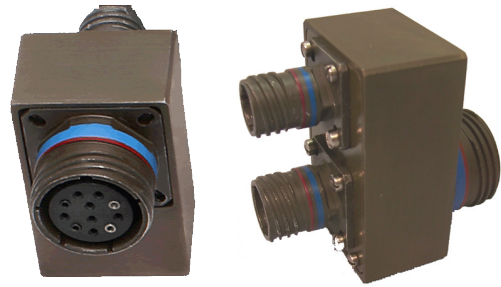

D38999 to D38999 / Optical to Electrical Media Converter

DESCRIPTION

Mercury series Fast Ethernet media converters consist of optoelectronic transmitter and receiver functions integrated along with the 100Base-TX Ethernet electrical to 100Base-FX optical media conversion circuitry into a bulkhead mounted MIL-DTL-38999 connector assembly.

The optical transmitters are high output 1310nm devices. The optical receivers consist of InGaAs PIN and preamplifier assemblies and limiting post-amplifiers.

The electrical interface to the Mercury series bulkhead optical media converters is a MIL-DTL-38999 connector enabling interconnection to an internal or external backbone cable interface.

Mercury series Fast Ethernet media converters are vibration isolated, environmentally hardened components designed for use in harsh environment applications.

- Sealed against liquid and solid contaminants
- Shock and vibration resistant

ORDERING INFORMATION

Application	Item Number
10/100Base-TX to 100Base-FX, 28VDC	M33R-2LAU-FW
See Appendix A4 for more part number options	

Single Port Mercury Series MIL-DTL-38999, 100Base-TX to 100Base-FX,
Fast Ethernet Media Converter, Multimode, 28VDC, 1310nm

ABSOLUTE MAXIMUM RATINGS

Absolute maximum limits mean that no catastrophic damage will occur if the product is subjected to these ratings for short periods, provided each limiting parameter is in isolation and all other parameters have values within the performance specification. It should not be assumed that limiting values of more than one parameter can be applied to the product at the same time.

Parameter	Symbol	Minimum	Typical	Maximum	Unit
Storage Temperature	T_s	-55		+100	°C
Supply Voltage	V_{cc}	-0.5		45.0	V
Data Input Voltage	V_i	-0.5		V_{cc}	V

RECOMMENDED OPERATING CONDITIONS

Parameter	Symbol	Minimum	Typical	Maximum	Unit
Operating Temperature	T_A	-40		+85	°C
Supply Voltage	V_{cc}	+4.5	+28.0	+36.0	VDC
Power Supply Noise (p-p)	N_p			200	mV

SPECIFICATIONS COMPLIANCE

Requirement	Feature	Condition	Notes
MIL-STD-883	ESD	Class II	2200V
MIL-STD-810	Vibration	3.8g ² /Hz	43G rms
MIL-STD-810	Shock	40.0g	6-9mS
MIL-STD-1344	Flame Resistance	Method 1012	30 Seconds
MIL-STD-1344	Damp Heat	10 Cycles	24 Hours
MIL-STD-38999	Mating Durability	500 Cycles	<0.5dB Change
FDA / CDRH / IEC-825-1	Eye Safety	Class 1	No Safety Interlocks Required

MATERIALS

Item	Detail	Notes
D38999 Cylindrical Shells	Aluminum Alloy	
Plating	Olive Drab Cadmium	
D38999 Inserts	Thermoplastic	
Interfacial Seals	Elastomer	
Optical Alignment Sleeves	Composite Polymer	
Printed Circuits	Polyimide / FR-4	Mil-P-31032 Type 4
Housing	Aluminum Alloy	

Single Port Mercury Series MIL-DTL-38999, 100Base-TX to 100Base-FX,
Fast Ethernet Media Converter, Multimode, 28VDC, 1310nM

TRANSMITTERS T_A = Operating Temperature Range

Parameter	Symbol	Minimum	Typical	Maximum	Unit
Optical Output Power	P_o	-19.0		-14.0	dBm
Optical Output Wavelength	λ_{OUT}	1260	1310	1380	nM

RECEIVERS T_A = Operating Temperature Range

Parameter	Symbol	Minimum	Typical	Maximum	Unit
Optical Sensitivity	P_i	-31.5		-12.0	dBm
Optical Wavelength	λ_{IN}	1100		1590	nM

SUPPLY CURRENT T_A = Operating Temperature Range

Parameter	Symbol	Minimum	Typical	Maximum	Unit
Supply Current per Port	I_{CCT}		100	150	mA

OPTICAL FIBER LINK DISTANCES

Application	Fiber Specification	Distance
Fast Ethernet - IEEE 802.3u	62.5/125 μ - 500MHz*Km	2.0Km
FDDI PMD ISO / IEC 9314-3	50/125 μ - 500MHz*Km	2.0Km

COPPER CABLE LINK DISTANCES

Application	Cable Specification	Distance
Fast Ethernet - IEEE 802.3u	TIA/EIA-568-B Cat 5*	100M

*for other transmission media, please consult the factory

Single Port Mercury Series MIL-DTL-38999, 100Base-TX to 100Base-FX,
Fast Ethernet Media Converter, Multimode, 28VDC, 1310nm

OUTLINE DRAWING

Dimensions are shown as: inches (mm)

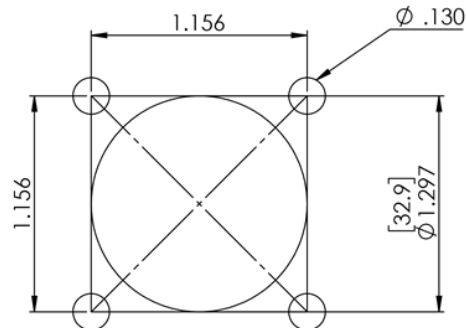
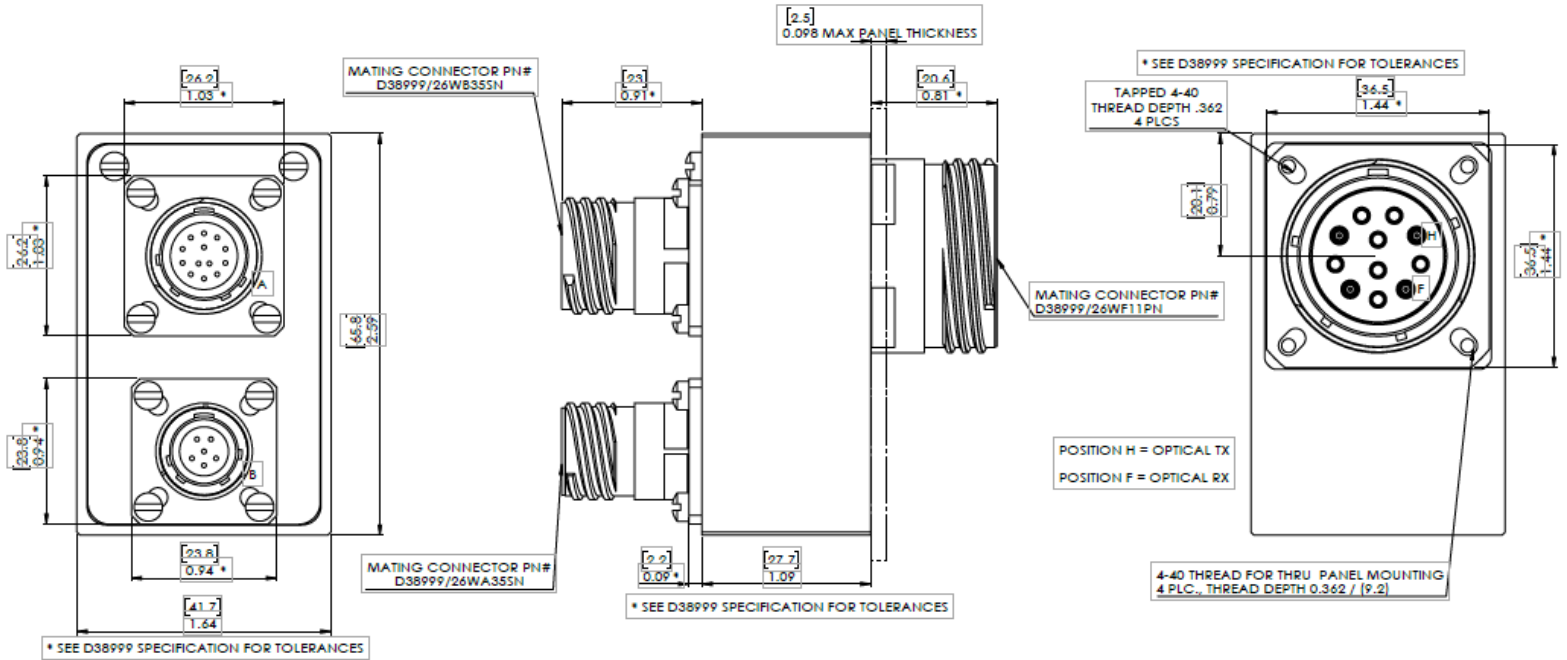

RECOMMENDED PANEL CUT OUT
PANEL THICKNESS 2.5MM MAX

Panel Cutout Dimensions
Rear Panel Mounting Only

Shell Size Code	Shell Size	M Min	P Holes	R Bsc
F	19	1.297 (32.94)	0.133 (3.4) 0.123 (3.1)	1.156 (29.4)

Single Port Mercury Series MIL-DTL-38999, 100Base-TX to 100Base-FX,
Fast Ethernet Media Converter, Multimode, 28VDC, 1310nm
MEDIA CONVERTER INSERT ARRANGEMENTS

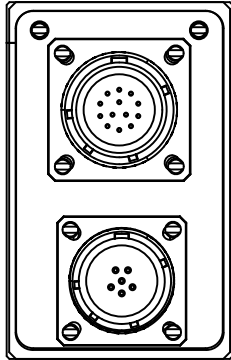

**Media Converter
Insert Pin Numbers**

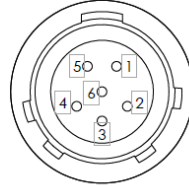
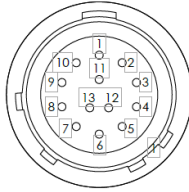

**Media Converter
Pin Functions**

10/100Base-TX

Pin 2 = TX+
Pin 5 = TX-
Pin 7 = RX+
Pin 10 = RX-
All Others Signal GND

Power Supply Interface 26-22 Guage Copper Wire
Pin 1, 2, 3, 4 = Case Ground D38999/26WA35SN

Pin 5 = VEE
Pin 6 = VCC

**Mating Cable Plug
Connector P/N**

D38999/26WB35SN
Cat-5E Twisted Pair Cable

Numbers and Functions Shown - Mating Cable Plug Opposite

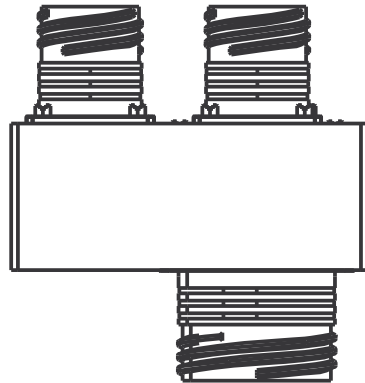
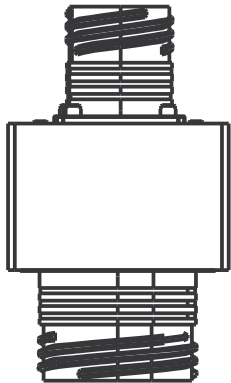

**Media Converter
Optical Pin Numbers**

**Media Converter
Optical Functions**

**Mating Cable Plug
Connector P/N**

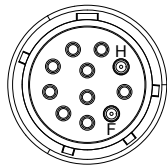
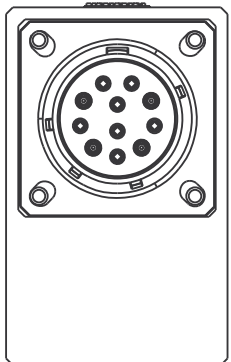

100Base-FX

Position H = Optical TX
Position F = Optical RX

62.5/125 Fiber Optic Cable

D38999/26WF11PN
M29504/04
See Appendix A2

MIL-STD-1560A Insert Code 19-11
MIL-T-29504/4B Optical Termini

Media Converter Fiber Pin Numbers and Functions Shown - Mating Cable Plug Opposite

Single Port Mercury Series MIL-DTL-38999, 100Base-TX to 100Base-FX,
Fast Ethernet Media Converter, Multimode, 28VDC, 1310nM

APPENDIX A1

RECEPTACLE PROTECTION CAPS

*MIL-DTL-38999/33 PROTECTION CAP PART NUMBERS

MS RECEPTACLE CAP P/N

*D38999/33W19R

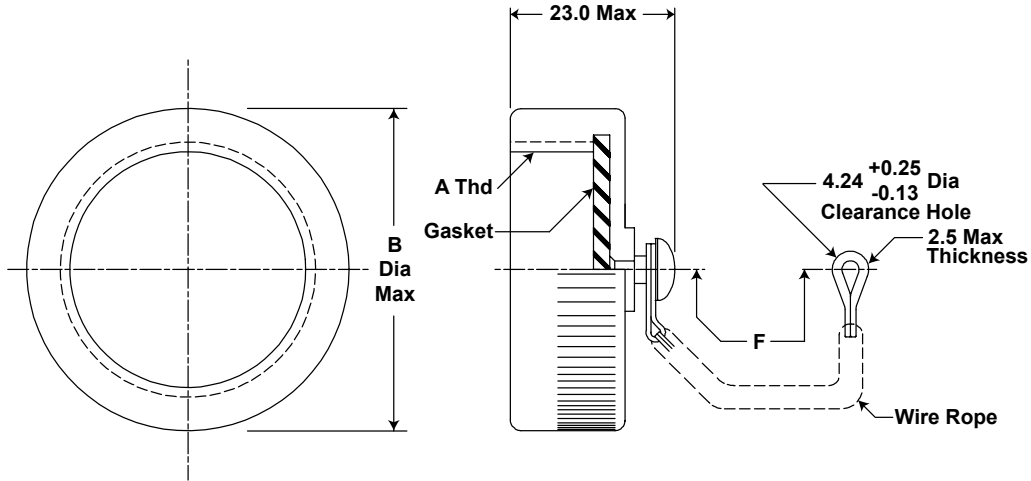

*See DSCC or SAE QPL for Approved Suppliers
<http://www.dscclia.mil/programs/qmlqpl/QPLdetail.asp?QPL=38999>

MIL-DTL-38999/33 Outline Dimensions - mm

Shell Size Code	Shell Size	A Thread (inches)	B Max Dia	F +13.0 -7.0
F	19	1.2500-0.1P-0.3L-TS	39.0	127.00

Single Port Mercury Series MIL-DTL-38999, 100Base-TX to 100Base-FX,
Fast Ethernet Media Converter, Multimode, 28VDC, 1310nm

APPENDIX A2

MIL-DTL-38999 FIBER OPTIC CABLE PLUG / MIL-T-29504 PIN TERMINI

*See DSCC or SAE QPL for Approved Suppliers

<http://www.dsccl.dla.mil/programs/qmlqpl/QPLdetail.asp?QPL=38999>

*D38999 PLUG - PIN INSERT

MIL-DTL-38999 CABLE PLUG

MS PLUG P/N

*D38999/26WF11PN

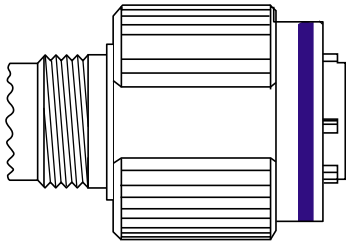

*FIBER OPTIC PIN TERMINUS

MIL-T-29504 PIN TERMINUS

MS PIN TERMINUS P/N

*M29504/04-xxxx**

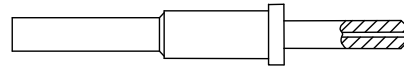

**defined by fiber optic cable configuration

*CABLE PROTECTION CAP

D38999/32 PLUG PROTECTION CAP

MS PLUG CAP P/N

*D38999/32W19N

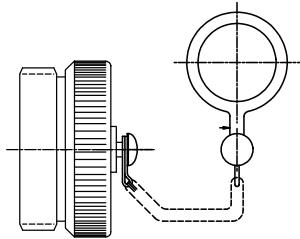

D38999 PLUG PORT FUNCTIONS

PORT NUMBER	TX	RX
0	H	F

TOP
Optical Cable Plug Interface

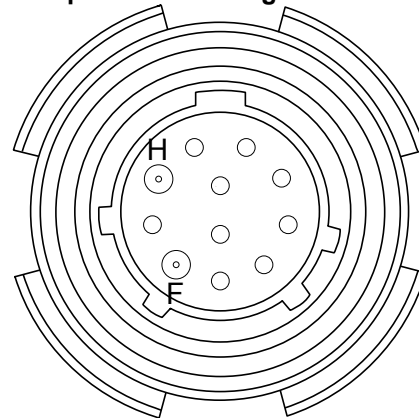

Front face of the optical cable plug pin insert shown. Transceiver insert opposite.

*CABLE BACKSHELL

MIL-C-85049 CABLE BACKSHELL

MS BACKSHELL P/N

*MS85049/xxxxxx**

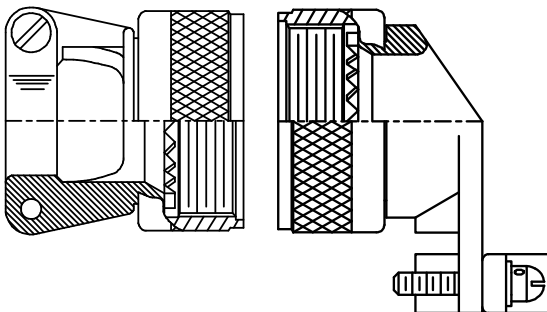

Pin Termini

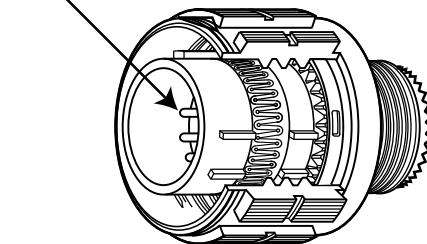

**Straight or angled backshell - defined by application / mounting configuration

APPENDIX A3

Electrical Data Cable - Connector Wiring Schematic

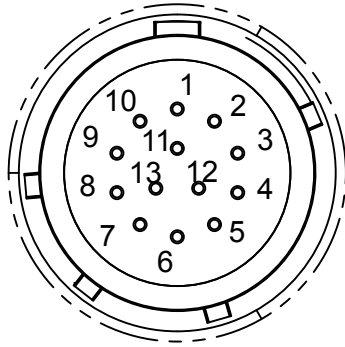

J2 = D38999/20WB35PN

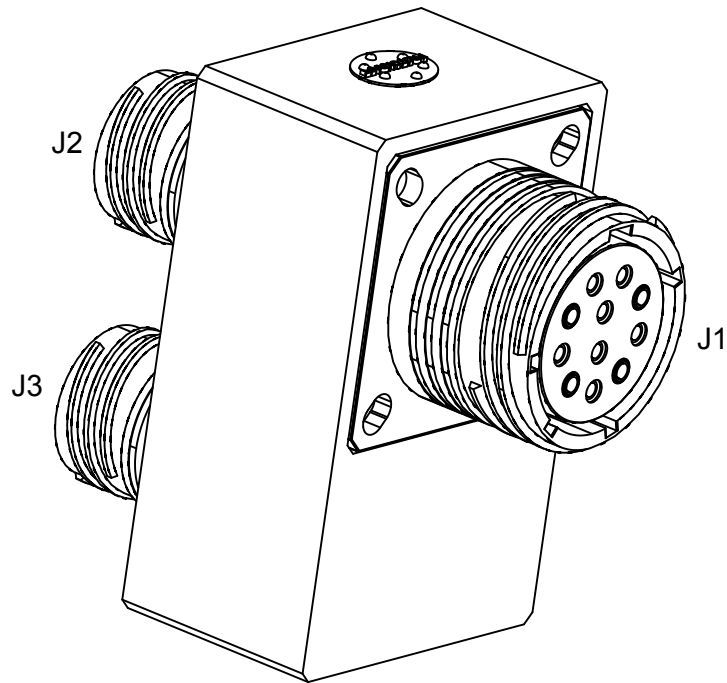

J2 MDIx wiring for connection to switch, hub or router

Pin Number	Function	RJ-45 Equivalent Pin #
2	TX+	1
5	TX-	2
7	RX+	3
10	RX-	6

J2 MDI wiring for connection to workstation, laptop or NIC

Pin Number	Function	RJ-45 Equivalent Pin #
2	TX+	3
5	TX-	6
7	RX+	1
10	RX-	2

TX functions are outputs, RX functions are inputs, all others are signal GND

Single Port Mercury Series MIL-DTL-38999, 100Base-TX to 100Base-FX,
Fast Ethernet Media Converter, Multimode, 28VDC, 1310nm

APPENDIX A4

PART NUMBER OPTIONS

Single Port, Fast Ethernet, Media Converter, 1310nm

M33R - 2 LAU - F X X

Shell Configuration
M33R= 38999 Receptacle

Channels (TX+RX)
2= 1TX + 1RX

Wavelength
L= 1310nm

Power Supply Voltage
A= 28.0VDC

Fiber Optic Interface
U = 125 Mbps

Shell Size Code
F = 19 - 11

Shell Plating
F = NI
W = OD CD / NI
Z = ZN / NI

Shell Polarization
(leave blank) _ = N
A = A
B = B
C = C
D = D

Other wavelength, mounting and port count options are available.
Please consult the Protokraft website for alternate configurations.



192 Bob Fitz Road, Johnson City, TN 37615
salesmp@moog.com
moogprotokraft.com