

## Mercury Series

Gigabit Ethernet, External D38999, 1000Base-T/SX Media Converter, 28Vdc, Multimode, 850nm VCSEL's

### Single Port, Flange Receptacles

#### FEATURES

- Compliant with IEEE-802.3:2005 Gigabit Ethernet
- Optical fiber link distances up to 550 Meters
- Maximum optical channel bit error rate less than  $1 \times 10^{-12}$
- Operating temperature range from  $-40^{\circ}\text{C}$  to  $+85^{\circ}\text{C}$
- Shock, vibration and immersion resistant per Mil-Std-810 and Mil-Std-1344
- Olive Drab Cadmium plating meets stringent EMI / RFI performance specifications
- Aluminum alloy chassis and Mil-Dtl-38999 housings are strong, durable, corrosion resistant and light weight
- Mil-T-29504 compliant optical fiber connector interface
- D38999 fiber optic insert configuration conforms to Mil-Std-1560
- D38999 electrical interfaces provides robust interconnection to vehicle or platform wiring

#### APPLICATIONS

Mercury series bulkhead mounted Gigabit Ethernet media converters enable high speed network communications over long distances in harsh environments.

- Gigabit Ethernet switches and peripherals
- Telecom and datacom switch / router rack-to-rack links
- Storage or computation clusters

The Mil-Dtl-38999, Series III connectors provide sealed optical and electrical interfaces that are water-tight to Mil-Std-810 / IP67 / NEMA-4x when mated.

The multimode optical fiber interface supports applications where copper cable link distance, bandwidth, weight or bulk make the use of twisted pair, twinax or quadrx copper conductors unacceptable.

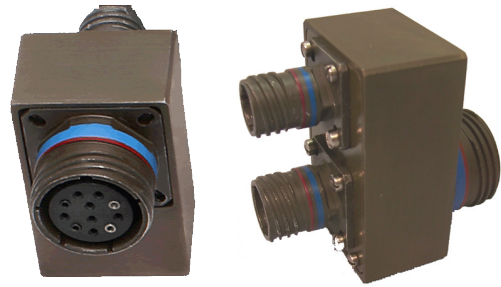

D38999 to D38999 / Optical to Electrical Media Converter

#### DESCRIPTION

Mercury series Gigabit Ethernet media converters consist of optoelectronic transmitter and receiver functions integrated along with the 1000Base-TX Ethernet electrical to 1000Base-SX optical media conversion circuitry into a bulkhead mounted MIL-DTL-38999 connector assembly.

The optical transmitters are high output 850nm devices. The optical receivers consist of InGaAs PIN and preamplifier assemblies and limiting post-amplifiers.

The electrical interface to the Mercury series bulkhead optical media converters is a MIL-DTL-38999 connector enabling interconnection to an internal or external backbone cable interface.

Mercury series Fast Ethernet media converters are vibration isolated, environmentally hardened components designed for use in harsh environment applications.

- Sealed against liquid and solid contaminants
- Shock and vibration resistant

#### ORDERING INFORMATION

Application	Item Number
1000Base-T to 1000Base-SX, 28Vdc	M33R-2SAT-FW
See Appendix A4 for more part number options	

Single Port Mercury Series Mil-Dtl-38999, 1000Base-T to 1000Base-SX,  
Gigabit Ethernet Media Converter, Multimode, 28Vdc, 850nm VCSEL's

## ABSOLUTE MAXIMUM RATINGS

Absolute maximum limits mean that no catastrophic damage will occur if the product is subjected to these ratings for short periods, provided each limiting parameter is in isolation and all other parameters have values within the performance specification. It should not be assumed that limiting values of more than one parameter can be applied to the product at the same time.

Parameter	Symbol	Minimum	Typical	Maximum	Unit
Storage Temperature	$T_s$	-55		+100	°C
Supply Voltage	$V_{cc}$	-0.5		45.0	V
Data Input Voltage	$V_i$	-0.5		$V_{cc}$	V

## RECOMMENDED OPERATING CONDITIONS

Parameter	Symbol	Minimum	Typical	Maximum	Unit
Operating Temperature	$T_A$	-40		+85	°C
Supply Voltage	$V_{cc}$	+4.5	+28.0	+36.0	VDC
Power Supply Noise (p-p)	$N_p$			200	mV

## SPECIFICATIONS COMPLIANCE

Requirement	Feature	Condition	Notes
MIL-STD-883	ESD	Class II	2200V
MIL-STD-810	Vibration	3.8g <sup>2</sup> /Hz	43G rms
MIL-STD-810	Shock	40.0g	6-9mS
MIL-STD-1344	Flame Resistance	Method 1012	30 Seconds
MIL-STD-1344	Damp Heat	10 Cycles	24 Hours
MIL-STD-38999	Mating Durability	500 Cycles	<0.5dB Change
FDA / CDRH / IEC-825-1	Eye Safety	Class 1	No Safety Interlocks Required

## MATERIALS

Item	Detail	Notes
D38999 Cylindrical Shells	Aluminum Alloy	
Plating	Olive Drab Cadmium	
D38999 Inserts	Thermoplastic	
Interfacial Seals	Elastomer	
Optical Alignment Sleeves	Composite Polymer	
Printed Circuits	Polyimide / FR-4	Mil-P-31032 Type 4
Housing	Aluminum Alloy	

Single Port Mercury Series Mil-Dtl-38999, 1000Base-T to 1000Base-SX,  
Gigabit Ethernet Media Converter, Multimode, 28Vdc, 850nm VCSEL's

### OPTICAL TRANSMITTERS $T_A$ = Operating Temperature Range

Parameter	Symbol	Minimum	Typical	Maximum	Unit
Optical Output Power	$P_o$	-9.5		-4.0	dBm
Optical Output Wavelength	$\lambda_{OUT}$	830	850	860	nM
Spectral Width	$\Delta\lambda_{RMS}$			0.85	nM

### OPTICAL RECEIVERS $T_A$ = Operating Temperature Range

Parameter	Symbol	Minimum	Typical	Maximum	Unit
Optical Sensitivity	$P_i$	-17.0		-2.0	dBm
Optical Wavelength	$\lambda_{IN}$	830	850	860	nM

### POWER SUPPLY CURRENT $T_A$ = Operating Temperature Range

Parameter	Symbol	Minimum	Typical	Maximum	Unit
Supply Current per Port @ 28VDC	$I_{cct}$		100	150	mA

### OPTICAL LINK DISTANCES

Protocol	Cable Specification	Distance
Gigabit Ethernet - IEEE-802.3:2005 - 1000BASE-SX	62.5/125 $\mu$ 200MHz*Km	275M
	50/125 $\mu$ 500MHz*Km	550M

### COPPER LINK DISTANCES

Protocol	Cable Specification	Distance
Gigabit Ethernet - IEEE-802.3:2005 - 1000BASE-T	TIA/EIA-568-B Cat 5E - for other transmission media, please consult the factory	100M

Single Port Mercury Series Mil-Dtl-38999, 1000Base-T to 1000Base-SX,  
Gigabit Ethernet Media Converter, Multimode, 28Vdc, 850nm VCSEL's

**OUTLINE DRAWING**

Dimensions are shown as: inches (mm)

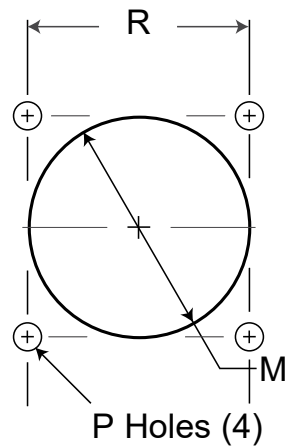
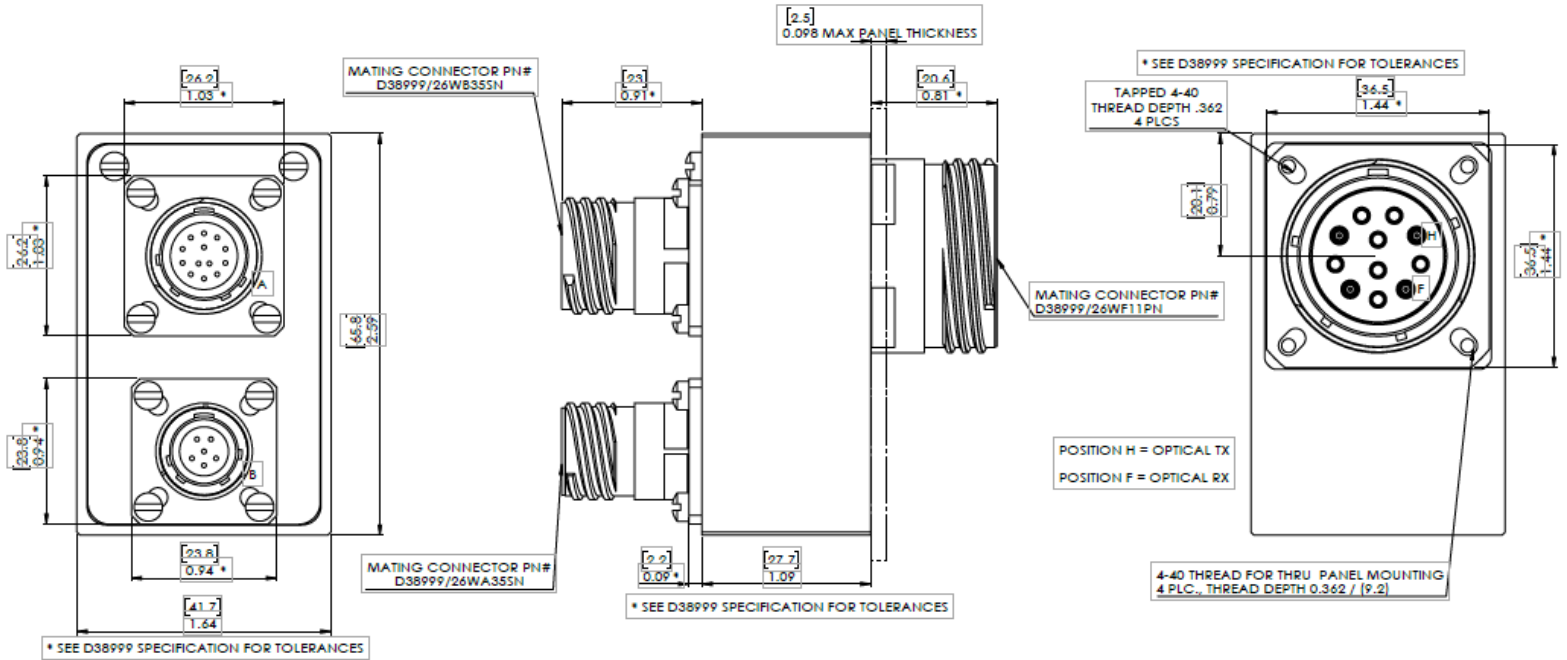

**Panel Cutout Dimensions**  
Rear Panel Mounting Only

Shell Size Code	Shell Size	M Min	P Holes	R Bsc
F	19	1.297 (32.94)	0.133 (3.4) 0.123 (3.1)	1.156 (29.4)

Single Port Mercury Series Mil-Dtl-38999, 1000Base-T to 1000Base-SX,  
Gigabit Ethernet Media Converter, Multimode, 28Vdc, 850nm VCSEL's  
**MEDIA CONVERTER INSERT ARRANGEMENTS**

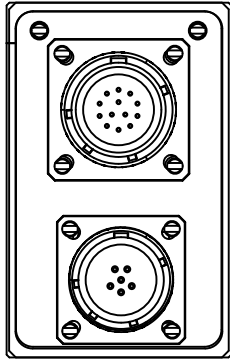

Media Converter  
Insert Pin Numbers

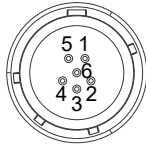
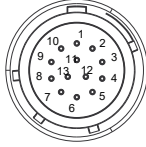

Media Converter  
Pin Functions

**1000Base-T**  
Pin 2= MDA+  
Pin 3= MDA-  
Pin 4= MDB+  
Pin 5= MDB-  
Pin 8= MDC+  
Pin 7= MDC-  
Pin10= MDD+  
Pin 9= MDD-

**Power Supply Connector**

Pin 1= Case Ground  
Pin 2= Case Ground  
Pin 3= Case Ground  
Pin 4= Case Ground  
Pin 5= VEE  
Pin 6= VCC

Mating Cable Plug  
Connector P/N

Cat-5E Twisted Pair Cable  
D38999/26WB35SN  
See Appendix A3  
All other pins = GND

26-22 Guage Copper Wire  
D38999/26WA35SN

Media Converter Pin Numbers and Functions Shown - Mating Cable Plug Opposite

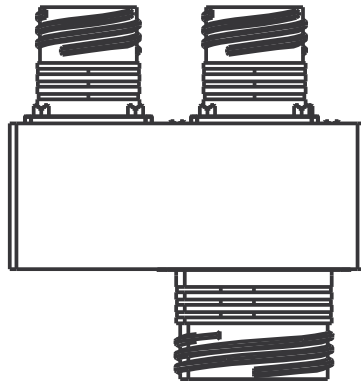
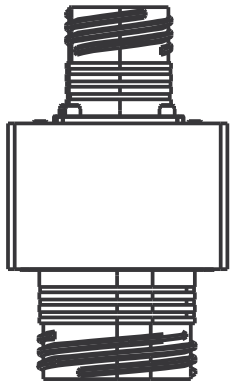

Media Converter  
Optical Pin Numbers

Media Converter  
Optical Functions

Mating Cable Plug  
Connector P/N

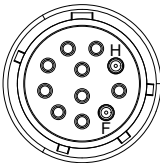
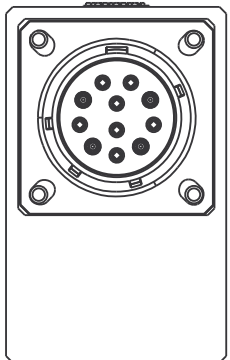

**1000Base-SX**  
Position H = Optical TX  
Position F = Optical RX

**62.5/125 Fiber Optic Cable**  
D38999/26WF11PN  
M29504/04  
See Appendix A2

MIL-STD-1560A Insert Code 19-11  
MIL-T-29504/4B Optical Termini

Media Converter Fiber Pin Numbers and Functions Shown - Mating Cable Plug Opposite

Single Port Mercury Series Mil-Dtl-38999, 1000Base-T to 1000Base-SX,  
Gigabit Ethernet Media Converter, Multimode, 28Vdc, 850nm VCSEL's

## APPENDIX A1

### RECEPTACLE PROTECTION CAPS

#### \*MIL-DTL-38999/33 PROTECTION CAP PART NUMBERS

MS RECEPTACLE CAP P/N

\*D38999/33W19R

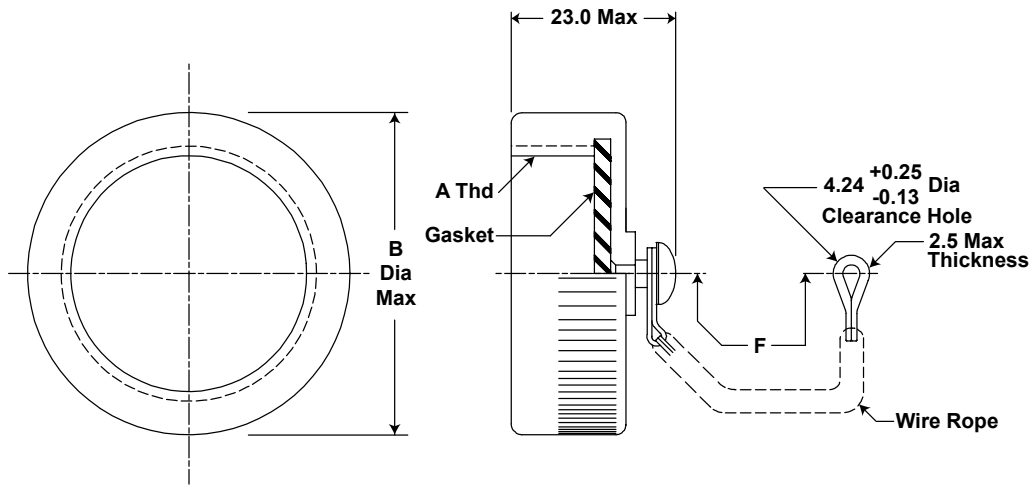

\*See DSCC or SAE QPL for Approved Suppliers  
<http://www.dscclia.mil/programs/qmlqpl/QPLdetail.asp?QPL=38999>

#### MIL-DTL-38999/33 Outline Dimensions - mm

Shell Size Code	Shell Size	A Thread (inches)	B Max Dia	F +13.0 -7.0
F	19	1.2500-0.1P-0.3L-TS	39.0	127.00

Single Port Mercury Series Mil-Dtl-38999, 1000Base-T to 1000Base-SX,  
Gigabit Ethernet Media Converter, Multimode, 28Vdc, 850nm VCSEL's

## APPENDIX A2

### MIL-DTL-38999 FIBER OPTIC CABLE PLUG / MIL-T-29504 PIN TERMINI

\*See DSCC or SAE QPL for Approved Suppliers

<http://www.dsccl.dla.mil/programs/qmlqpl/QPLdetail.asp?QPL=38999>

#### \*D38999 PLUG - PIN INSERT

##### MIL-DTL-38999 CABLE PLUG

MS PLUG P/N

\*D38999/26WF11PN

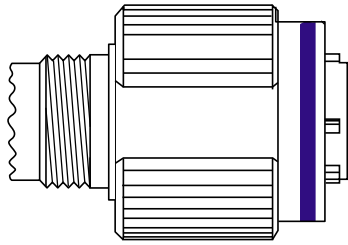

#### \*FIBER OPTIC PIN TERMINUS

##### MIL-T-29504 PIN TERMINUS

MS PIN TERMINUS P/N

\*M29504/04-xxxx\*\*



\*\*Defined by fiber optic cable configuration

#### \*CABLE PROTECTION CAP

##### D38999/32 PLUG PROTECTION CAP

MS PLUG CAP P/N

\*D38999/32W19N

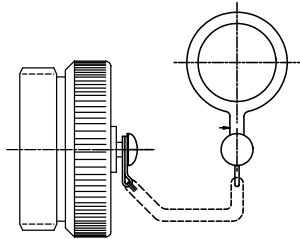

#### D38999 PLUG PORT FUNCTIONS

PORT NUMBER	TX	RX
0	H	F

TOP  
Optical Cable Plug Interface

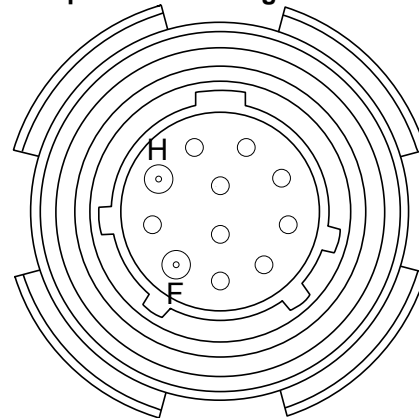

Front face of the optical cable plug pin insert shown. Transceiver insert opposite.

#### \*CABLE BACKSHELL

##### MIL-C-85049 CABLE BACKSHELL

MS BACKSHELL P/N

\*MS85049/xxxxxx\*\*

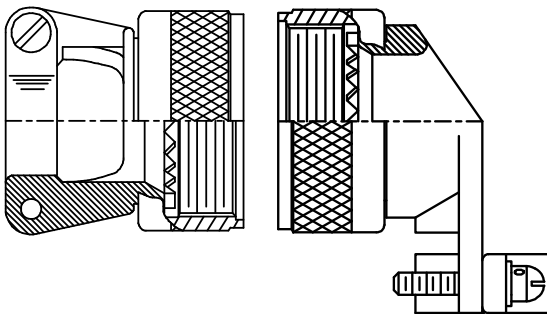

Pin Termini

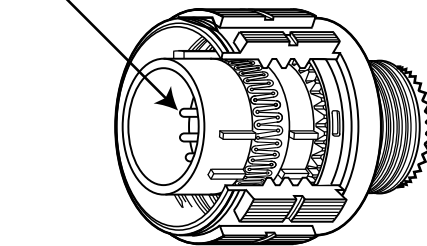

\*\*Straight or angled backshell - defined by application / mounting configuration

Single Port Mercury Series Mil-Dtl-38999, 1000Base-T to 1000Base-SX,  
Gigabit Ethernet Media Converter, Multimode, 28Vdc, 850nm VCSEL's

## APPENDIX A3

### Electrical Data Cable - Connector Wiring Schematic

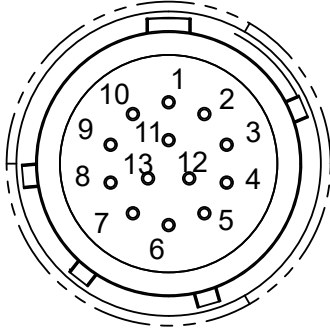

J2 Pin Functions	RJ-45 Equiv. Pin #
Pin 2= MDA+	1
Pin 3= MDA-	2
Pin 4= MDB+	3
Pin 5= MDB-	6
Pin 8= MDC+	4
Pin 7= MDC-	5
Pin10= MDD+	7
Pin 9= MDD-	8
All others are signal ground	

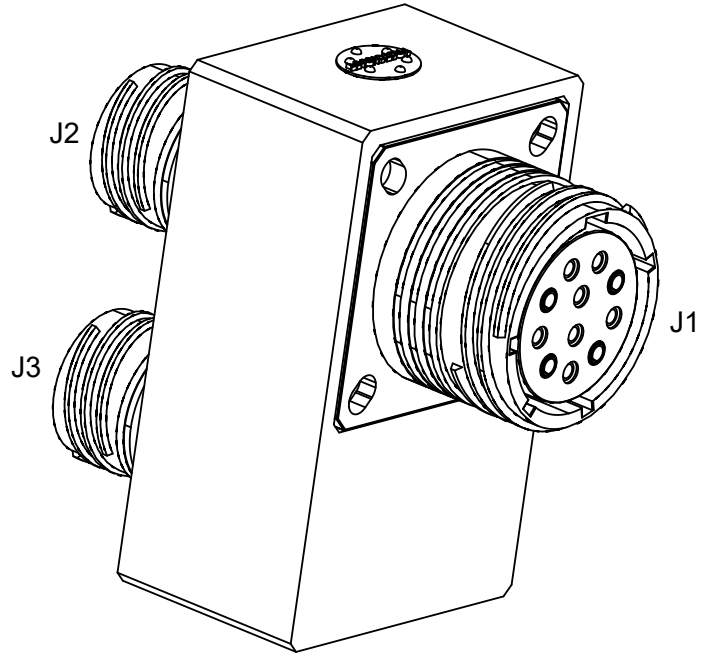



Single Port Mercury Series Mil-Dtl-38999, 1000Base-T to 1000Base-SX,  
Gigabit Ethernet Media Converter, Multimode, 28Vdc, 850nm VCSEL's

## APPENDIX A4

### PART NUMBER OPTIONS

Single Port, Gigabit Ethernet, 850nm

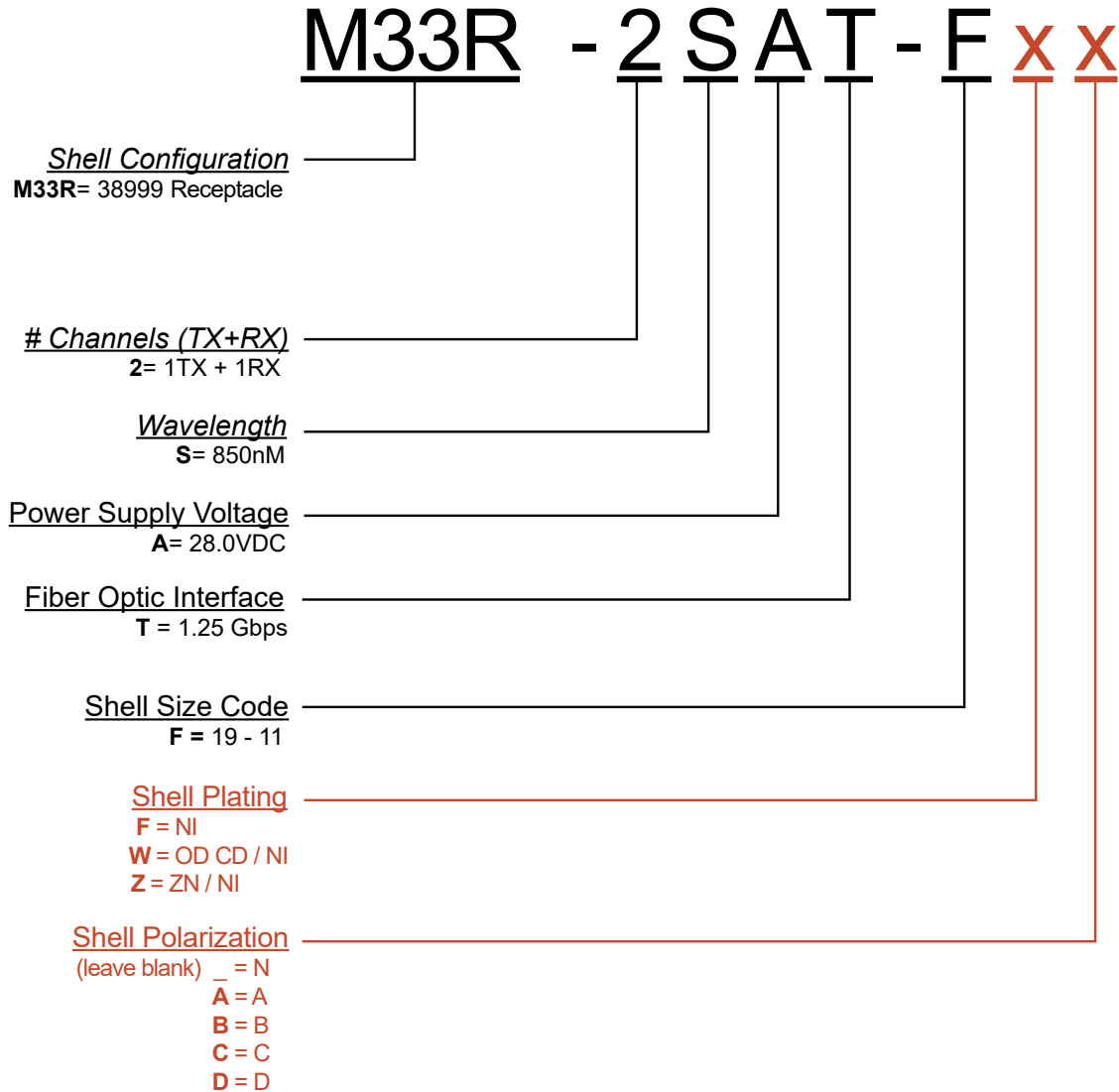

Other wavelength, mounting and port count options are available.  
Please consult the Protokraft website for alternate configurations.



192 Bob Fitz Road, Johnson City, TN 37615  
salesmp@moog.com  
moogprotokraft.com