



NEPTUNE SERIES

ETHERNET MEDIA CONVERTER, QUAD PORT 1000BASE-T / SX (850 NM), M28876, +28 VDC



Neptune series Ethernet media converters consist of optoelectronic transmitter and receiver functions integrated along with 1000Base-T to 1000Base-SX optical media conversion circuitry into a wall mounted M28876 connector assembly.

Optical transmitters are high output 850 nm VCSEL's. The optical receivers consist of GaAs PIN with preamplifier assemblies and InGaAs PIN with preamplifier assemblies.

The electrical interface to the Neptune series optical media converters is a MIL-DTL-83513 Micro D Subminiature pin connector enabling interconnection to a customer supplied flexible circuit or cable assembly.

Neptune series Ethernet media converters are vibration isolated, environmentally hardened components designed for use in harsh environment applications.

- Sealed against liquid and solid contaminants
- Shock and vibration resistant

NEPTUNE SERIES M28876 CONNECTOR, 1000BASE-T TO 1000BASE-SX, ETHERNET MEDIA CONVERTER, MULTIMODE, 28 VDC, 850 NM

Quad Port, Jam Nut Receptacles
M28876 / Optical to Electrical Media Converter

FEATURES

- Compliant with IEEE-802.3:2005 Ethernet
- Optical fiber link distances up to 550 meters for GbE
- Maximum optical channel bit error rate less than 1×10^{-12}
- Operating temperature range from -40° to $+85^{\circ}$ C
- Black zinc nickel over aluminum meets stringent EMI / RFI performance specifications
- M28876 and M83513 connectors are strong, durable and corrosion resistant
- M28876 compliant optical fiber connector interface

APPLICATIONS

Neptune series bulkhead mounted Ethernet media converters enable high speed network communications over long distances in harsh environments.

- Ethernet switches and peripherals
- Telecom and datacom switch / router rack-to-rack links
- Storage or computation clusters

The M28876 optical and M83513 electrical connectors provide sealed optical and electrical interfaces that are water-tight to MIL-STD-810 / IP67 / NEMA-4x when mated.

The multimode optical fiber interface supports applications where copper cable link distance, bandwidth, weight or bulk make the use of twisted pair, twinax or quadax copper conductors unacceptable.

NEPTUNE SERIES M28876 CONNECTOR, 1000BASE-T TO 1000BASE-SX, ETHERNET MEDIA CONVERTER, MULTIMODE, 28 VDC, 850 NM

ABSOLUTE MAXIMUM RATINGS

Absolute maximum limits mean that no catastrophic damage will occur if the product is subjected to these ratings for short periods, provided each limiting parameter is in isolation and all other parameters have values within the performance specification. It should not be assumed that limiting values of more than one parameter can be applied to the product at the same time.

Parameter	Symbol	Minimum	Typical	Maximum	Unit
Storage Temperature	T_s	-55		+100	°C
Supply Voltage	V_{cc}	-0.5		38.0	V

RECOMMENDED OPERATING CONDITIONS

Parameter	Symbol	Minimum	Typical	Maximum	Unit
Operating Temperature	T_A	-40		+85	°C
Supply Voltage	V_{cc}	+18.0	+28.0	+36.0	VDC

CONNECTOR INTERFACE SPECIFICATIONS COMPLIANCE

Requirement	Feature	Condition	Notes
MIL-STD-883	ESD	Class II	2200 V
MIL-STD-810	Vibration	30.0 g	18 ms
MIL-STD-810	Shock	40.0 g	6-9 ms
MIL-STD-1344	Flame Resistance	Method 1012	30 Seconds
MIL-STD-1344	Damp Heat	10 Cycles	24 Hours
M28876	Mating Durability	2000 Cycles	EIA / TIA-455-21

MATERIALS

Item	Detail	Notes
M28876 Cylindrical Shells	Aluminum	
Plating	Black Zinc Nickel	Per ASTM B671 / AMS 2417
M28876 Inserts	Aluminum	
Interfacial Seals	Elastomer	
M28876 Jam Nut Connector Seal	Conductive Elastomer	
M28876 Bonding	2.5 mΩ to First Faying Surface	Connector to Media Converter Housing Connector Shell to Chassis Panel
M28876 Jam Nut	Stainless Steel	
Optical Ferrules	Zirconia	
Printed Circuits	Polyimide / FR-4	MIL-P-31032 Type 4
Housing Aluminum		
Housing Finish	Type II, Class 3	Per MIL-DTL-5541
Micro-D Shell	Aluminum, Nickel Plated	
Micro-D Finish	Black Zinc Nickel	Per ASTM B671 / AMS 2417
Micro-D Bonding	2.5 mΩ to First Faying Surface	Connector to Media Converter Housing

NEPTUNE SERIES M28876 CONNECTOR, 1000BASE-T TO 1000BASE-SX, ETHERNET MEDIA CONVERTER, MULTIMODE, 28 VDC, 850 NM

OPTICAL TRANSMITTERS T_A = OPERATING TEMPERATURE RANGE

Parameter	Symbol	Minimum	Typical	Maximum	Unit
Optical Output Power - GbE	P_o	-9.5		-3.0	dBm
Optical Output Wavelength - GbE	λ_{OUT}	830	850	860	nM
Spectral Width - GbE	$\Delta\lambda_{RMS}$			0.85	nM

OPTICAL RECEIVERS T_A = OPERATING TEMPERATURE RANGE

Parameter	Symbol	Minimum	Typical	Maximum	Unit
Optical Sensitivity - GbE	P_i	-17.0		-2.0	dBm
Optical Wavelength - GbE	λ_{IN}	830	850	860	nM

POWER SUPPLY CURRENT T_A = OPERATING TEMPERATURE RANGE

Parameter	Symbol	Minimum	Typical	Maximum	Unit
Supply Current per Port @ 28VDC	I_{CCT}		100	150	mA

OPTICAL LINK DISTANCES

Protocol	Cable Specification	Distance
Gigabit Ethernet - IEEE-802.3:2005 - 1000BASE-SX	6.25 / 125 μ 200 MHz*Km	275 M
	50 / 125 μ 500 MHz*Km	550 M

COPPER LINK DISTANCES

Protocol	Cable Specification	Distance
Gigabit Ethernet - IEEE-802.3:2005 - 1000BASE-T	TIA / EIA-568-B Cat 5E - for other transmission media, please consult the factory	100 M

NEPTUNE SERIES M28876 CONNECTOR, 1000BASE-T TO 1000BASE-SX, ETHERNET MEDIA CONVERTER, MULTIMODE, 28 VDC, 850 NM

OUTLINE DRAWING

J1 connector master keyway at 12:00 ('N')

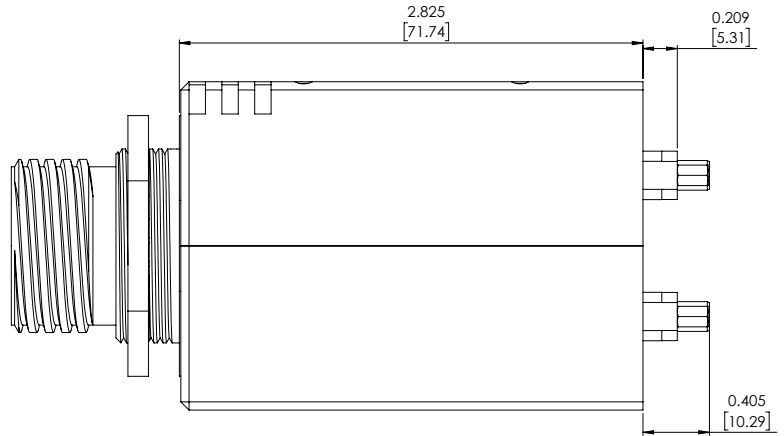
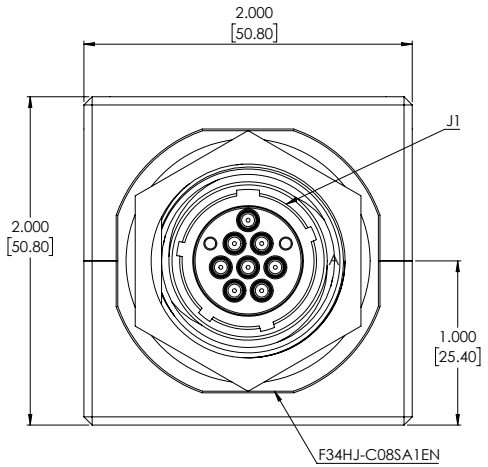

Use conductive o-ring P/N FSPP-309-12-027
Use Amphenol FS3M-000-01-711 alignment sleeve and Amphenol equivalent termini

Dimensions are shown as: inches [mm]

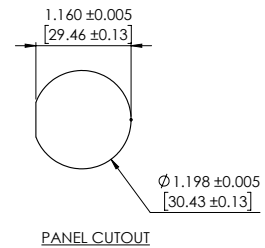
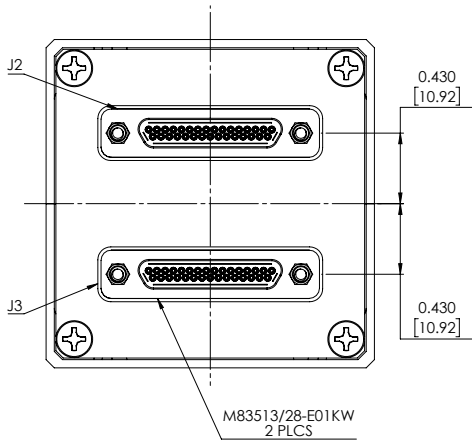

NEPTUNE SERIES M28876 CONNECTOR, 1000BASE-T TO 1000BASE-SX, ETHERNET MEDIA CONVERTER, MULTIMODE, 28 VDC, 850 NM

APPENDIX A1

M28876/7 8 Channel Fiber Optic Cable Plug

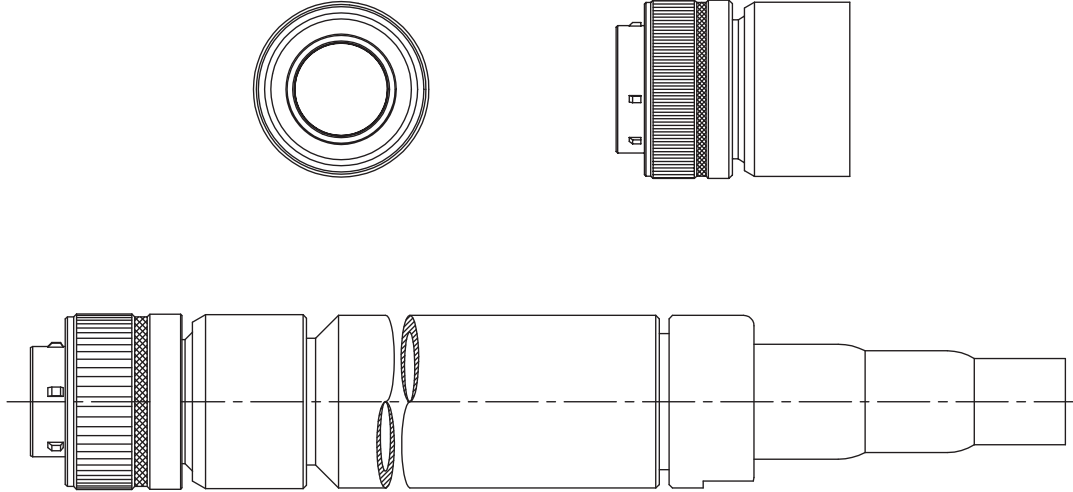

*M28876 FIBER OPTIC CABLE PLUG

Configuration	Generic P/N
8 Fiber / Size 15 Shell / Pol 1	M28876 / 7-C12P1
Termini - Multimode	M29504 / 14-4131C

NEPTUNE SERIES M28876 CONNECTOR, 1000BASE-T TO 1000BASE-SX, ETHERNET MEDIA CONVERTER, MULTIMODE, 28 VDC, 850 NM

APPENDIX A2 - J1 SOCKET FUNCTIONS FIBER CONNECTOR WIRING SCHEMATIC

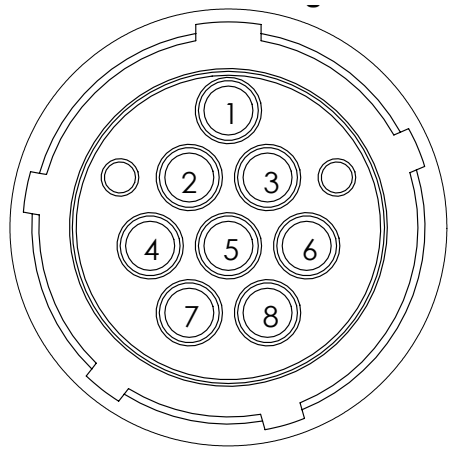

DETAIL A SCALE 4 : 1

J1				
Pin	Port	Function	Input / Output	Logic Family
1	1	TX	Output	1000Base-SX
2	1	RX	Input	1000Base-SX
3	0	TX	Output	1000Base-SX
4	2	RX	Input	1000Base-SX
5	2	TX	Output	1000Base-SX
6	0	RX	Input	1000Base-SX
7	3	RX	Input	1000Base-SX
8	3	TX	Output	1000Base-SX

NEPTUNE SERIES M28876 CONNECTOR, 1000BASE-T TO 1000BASE-SX, ETHERNET MEDIA CONVERTER, MULTIMODE, 28 VDC, 850 NM

APPENDIX A3 - J2 J3 PIN FUNCTIONS - POWER SUPPLY CONNECTOR

ELECTRICAL POWER CABLE - CONNECTOR WIRING SCHEMATIC

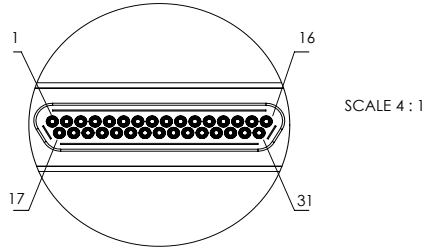

J2						J3					
Pin	Port	Function	Input / Output	RJ-45 Pin	Logic Family	Pin	Port	Function	Input / Output	RJ-45 Pin	Logic Family
1	0	DD-	Input / Output	8	IEEE 802.3 1000Base-T	1	3	DA+	Input / Output	1	IEEE 802.3 1000Base-T
2	0	DC-	Input / Output	5	IEEE 802.3 1000Base-T	2	3	DB+	Input / Output	3	IEEE 802.3 1000Base-T
3	0	DB-	Input / Output	6	IEEE 802.3 1000Base-T	3	3	DC+	Input / Output	4	IEEE 802.3 1000Base-T
4	0	DA-	Input / Output	2	IEEE 802.3 1000Base-T	4	3	DD+	Input / Output	7	IEEE 802.3 1000Base-T
5	-	NC	-	-	-	5	-	NC	-	-	-
6	-	NC	-	-	-	6	-	NC	-	-	-
7	1	DA-	Input / Output	2	IEEE 802.3 1000Base-T	7	2	DD+	Input / Output	7	IEEE 802.3 1000Base-T
8	1	DB-	Input / Output	6	IEEE 802.3 1000Base-T	8	2	DC+	Input / Output	4	IEEE 802.3 1000Base-T
9	1	DC-	Input / Output	5	IEEE 802.3 1000Base-T	9	2	DB+	Input / Output	3	IEEE 802.3 1000Base-T
10	1	DD-	Input / Output	8	IEEE 802.3 1000Base-T	10	2	DA+	Input / Output	1	IEEE 802.3 1000Base-T
11	-	NC	-	-	Factory Use Only	11	-	NC	-	-	Factory Use Only
12	-	NC	-	-	-	12	-	NC	-	-	-
13	-	NC	-	-	-	13	-	NC	-	-	-
14	All	Case	-	-	Case	14	-	NC	-	-	-
15	All	28 VDC RTN	-	-	18-36 VDC RTN	15	-	NC	-	-	-
16	All	28 VDC SPLY	-	-	18-36 VDC SPLY	16	-	NC	-	-	-
17	0	DD+	Input / Output	7	IEEE 802.3 1000Base-T	17	3	DA-	Input / Output	2	IEEE 802.3 1000Base-T
18	0	DC+	Input / Output	4	IEEE 802.3 1000Base-T	18	3	DB-	Input / Output	6	IEEE 802.3 1000Base-T
19	0	DB+	Input / Output	3	IEEE 802.3 1000Base-T	19	3	DC-	Input / Output	5	IEEE 802.3 1000Base-T
20	0	DA+	Input / Output	1	IEEE 802.3 1000Base-T	20	3	DD-	Input / Output	8	IEEE 802.3 1000Base-T
21	-	NC	-	-	-	21	-	NC	-	-	-
22	-	NC	-	-	-	22	-	NC	-	-	-
23	1	DA+	Input / Output	1	IEEE 802.3 1000Base-T	23	2	DD-	Input / Output	8	IEEE 802.3 1000Base-T
24	1	DB+	Input / Output	3	IEEE 802.3 1000Base-T	24	2	DC-	Input / Output	5	IEEE 802.3 1000Base-T
25	1	DC+	Input / Output	4	IEEE 802.3 1000Base-T	25	2	DB-	Input / Output	6	IEEE 802.3 1000Base-T
26	1	DD+	Input / Output	7	IEEE 802.3 1000Base-T	26	2	DA-	Input / Output	2	IEEE 802.3 1000Base-T
27	-	NC	-	-	Factory Use Only	27	-	NC	-	-	Factory Use Only
28	-	NC	-	-	-	28	-	NC	-	-	-
29	All	Case	-	-	Case	29	-	NC	-	-	-
30	All	28 VDC RTN	-	-	18-36 VDC RTN	30	-	NC	-	-	-
31	All	28 VDC SPLY	-	-	18-36 VDC SPLY	31	-	NC	-	-	-

NEPTUNE SERIES M28876 CONNECTOR, 1000BASE-T TO 1000BASE-SX, ETHERNET MEDIA CONVERTER, MULTIMODE, 28 VDC, 850 NM

APPENDIX A4 - J2 SOCKET FUNCTIONS

J3						J3					
Pin	Port	Function	Input / Output	RJ-45 Pin	Logic Family	Pin	Port	Function	Input / Output	RJ-45 Pin	Logic Family
5	0	DA+	Input / Output	1	IEEE 802.3 1000Base-T	30	1	DA+	Input / Output	1	IEEE 802.3 1000Base-T
6	0	DB+	Input / Output	3	IEEE 802.3 1000Base-T	31	1	DB+	Input / Output	3	IEEE 802.3 1000Base-T
7	0	DC+	Input / Output	4	IEEE 802.3 1000Base-T	32	1	DC+	Input / Output	4	IEEE 802.3 1000Base-T
8	0	DD+	Input / Output	7	IEEE 802.3 1000Base-T	33	1	DD+	Input / Output	7	IEEE 802.3 1000Base-T
11	0	DA-	Input / Output	2	IEEE 802.3 1000Base-T	39	1	DA-	Input / Output	2	IEEE 802.3 1000Base-T
12	0	DB-	Input / Output	6	IEEE 802.3 1000Base-T	40	1	DB-	Input / Output	6	IEEE 802.3 1000Base-T
13	0	DC-	Input / Output	5	IEEE 802.3 1000Base-T	41	1	DC-	Input / Output	5	IEEE 802.3 1000Base-T
14	0	DD-	Input / Output	8	IEEE 802.3 1000Base-T	42	1	DD-	Input / Output	8	IEEE 802.3 1000Base-T
25	2	DA+	Input / Output	1	IEEE 802.3 1000Base-T	52	3	DD+	Input / Output	7	IEEE 802.3 1000Base-T
26	2	DB+	Input / Output	3	IEEE 802.3 1000Base-T	53	3	DC+	Input / Output	4	IEEE 802.3 1000Base-T
27	2	DC+	Input / Output	4	IEEE 802.3 1000Base-T	54	3	DB+	Input / Output	3	IEEE 802.3 1000Base-T
28	2	DD+	Input / Output	7	IEEE 802.3 1000Base-T	55	3	DA+	Input / Output	1	IEEE 802.3 1000Base-T
34	2	DA-	Input / Output	2	IEEE 802.3 1000Base-T	59	3	DD-	Input / Output	8	IEEE 802.3 1000Base-T
35	2	DB-	Input / Output	6	IEEE 802.3 1000Base-T	60	3	DC-	Input / Output	5	IEEE 802.3 1000Base-T
36	2	DC-	Input / Output	5	IEEE 802.3 1000Base-T	61	3	DB-	Input / Output	6	IEEE 802.3 1000Base-T
37	2	DD-	Input / Output	8	IEEE 802.3 1000Base-T	62	3	DA-	Input / Output	2	IEEE 802.3 1000Base-T



192 Bob Fitz Road, Johnson City, TN 37615
 salesmp@moog.com
 moogprotokraft.com